

141 PROFLOW

Series 'B' Vane meters



Publication nr
Supersedes

TIB-141-GB-0113
TIB-141-GB-0811

WWW.VAF.NL

**TO BE
REALLY
SURE**

CONTENTS

| | |
|---|----|
| 1. PREFACE | 3 |
| 1.1 General | 3 |
| 1.2 Symbols | 3 |
| 1.3 Copyright | 3 |
| 2. PRODUCT DESCRIPTION..... | 4 |
| 2.1 Principle of operation | 4 |
| 3. TECHNICAL SPECIFICATIONS..... | 5 |
| 3.1 Flowmeter | 5 |
| 3.2 Optional pulse transmitter | 5 |
| 3.2.1 Technical specification of pulse transmitters..... | 5 |
| 3.2.2 Intrinsic safe operation | 5 |
| 3.3 Optional pulse discriminator..... | 6 |
| 3.3.1 Technical specifications of the pulse discriminator | 6 |
| 3.4 Liquid filter | 6 |
| 3.5 Weight of flowmeters and counters..... | 7 |
| 4. SAFETY INSTRUCTIONS | 7 |
| 5. UNPACKING | 7 |
| 6. INSTALLATION AND FIRST USE | 7 |
| 6.1 Before installing Flowmeter..... | 7 |
| 6.2 General | 8 |
| 6.3 System layout recommendations | 8 |
| 6.3.1 Supporting the flow meter | 9 |
| 6.3.2 Bypass piping arrangement | 9 |
| 6.3.3 To prevent the flowmeter from emptying..... | 9 |
| 6.3.4 To prevent measuring air | 9 |
| 6.4 To install flowmeter | 10 |
| 6.5 Electric connection diagrams | 10 |
| 6.5.1 Connection cables | 10 |
| 6.5.2 Connections at totaliser..... | 11 |
| 6.5.3 Connections at 6-pole connector | 11 |
| 6.5.4 External connections at pulse transmitter box..... | 12 |
| 7. OPERATING INSTRUCTIONS | 13 |
| 7.1 Start-up procedures | 13 |
| 7.1.1 Initial start-up of a flowmeter system with bypass | 14 |
| 7.1.2 Initial start-up of a flowmeter system without bypass | 14 |
| 7.2 Operation of counters | 14 |
| 7.2.1 Totaliser | 15 |
| 7.2.2 FlowCount Rate-Totaliser | 15 |
| 8. MAINTENANCE | 16 |
| 8.1 General | 16 |
| 8.2 Accuracy check..... | 16 |
| 8.3 Check of totalisers | 16 |
| 9. SERVICE AND REPAIR INSTRUCTIONS..... | 17 |

| | | |
|--------|---|----|
| 9.1 | General | 17 |
| 9.2 | To remove Flowmeter from piping system | 17 |
| 9.2.1 | General procedure | 17 |
| 9.2.2 | To empty piping system | 17 |
| 9.2.3 | To drain flowmeter | 17 |
| 9.2.4 | To remove flowmeter from piping system | 17 |
| 9.3 | Dismantling | 18 |
| 9.3.1 | To remove flowmeter from liquid piping | 18 |
| 9.3.2 | To remove counter from flowmeter | 18 |
| 9.3.3 | To remove magnet cap and magnet | 19 |
| 9.3.4 | To remove front cover | 20 |
| 9.3.5 | To remove rotor/vanes assembly | 21 |
| 9.3.6 | To remove back cover | 23 |
| 9.3.7 | To inspect inside of meter body | 23 |
| 9.3.8 | To inspect rotor and vanes | 24 |
| 9.3.9 | To inspect bearings and rotor shaft | 24 |
| 9.3.10 | To replace bearings | 25 |
| 9.4 | To re-assemble a flowmeter | 25 |
| 9.4.1 | General | 25 |
| 9.4.2 | To install back cover | 25 |
| 9.4.3 | To install front cover to meter body | 28 |
| 9.4.4 | To install inner magnet | 29 |
| 9.4.5 | To install magnet cap | 29 |
| 9.4.6 | To install pulse transmitter box or counter | 30 |
| 9.5 | Final performance check | 30 |
| 9.6 | Changing the flow direction | 31 |
| 10. | TAKE OUT OF SERVICE | 32 |
| 11. | REMOVAL AND STORAGE OF EQUIPMENT | 32 |
| 12. | MALFUNCTION AND SEND FOR REPAIR | 32 |
| 13. | ENVIRONMENT | 34 |
| 14. | DISPOSAL | 34 |
| 15. | TROUBLE SHOOTING | 34 |
| 15.1 | Trouble shooting chart | 34 |
| 15.2 | Conditions for return of goods | 35 |
| 16. | CERTIFICATES | 36 |
| 17. | DRAWINGS | 37 |
| 17.1 | Assembly drawings and parts-lists | 37 |
| 17.2 | Dimensional drawings | 46 |
| 18. | ABBREVIATIONS | 49 |
| 19. | SPARE PARTS | 49 |
| 20. | WARRANTY CONDITIONS | 50 |

1. PREFACE

1.1 GENERAL

This manual contains installation, operation and maintenance instructions for VAF Series 'B' ProFlow liquid flowmeters, model series "B" ProFlow with connection sizes DN15 (½") to DN 50 (2").

This manual contains important information for the installer, the operator and for your maintenance department.



To ensure safe and correct installation and operation of your VAF flowmeter study this manual carefully before starting operations.

For associated equipment supplied by VAF Instruments B.V. separate instruction manuals are included with those products.

For any additional information contact:

| | | |
|---------------------------------------|-----------|--|
| VAF Instruments B.V. | Tel. | +31 78 618 3100 |
| Vierlinghstraat 24, 3316 EL Dordrecht | Fax | +31 78 617 7068 |
| P.O. Box 40, NL-3300 AA Dordrecht | E-mail: | sales@vaf.nl |
| The Netherlands | Internet: | www.vaf.nl |

Or your local authorized VAF dealer.

Their addresses can be found on www.vaf.nl

1.2 SYMBOLS

The symbols below are used to call attention to specific types of information.



A warning to use caution! In some instances, personal injury or damage to the flowmeter or control system may result if these instructions are not followed properly.



An explanation or information of interest.

1.3 COPYRIGHT

This manual is copyrighted with all rights reserved. No part of this book may be copied or reproduced by any means without permission from VAF Instruments.

While every precaution has been taken in the preparation of this manual, no responsibility for errors or omissions is assumed. Neither is any liability assumed for damages resulting from the use of the information contained herein. Specifications can be changed without notice.

2. PRODUCT DESCRIPTION

The ProFlow flowmeter is used to measure the flow of a fluid. The read out of the flowmeter is a 6-digit and a pointer non-resettable counter.

The flowmeter can be equipped with optional pulse transmitter(s), LCD counter.

2.1 PRINCIPLE OF OPERATION

Series ProFlow meters operate on the sliding vane principle. The meter consists of a specially shaped housing in which a rotor can rotate freely. Two pairs of vanes are fitted into four slots in the rotor. Each pair is positioned by a rod and can move in and out of the rotor. The radial vane movement is guided by the special inner shape of the housing. This patented construction provides a dynamic seal between the inlet and the outlet of the flowmeter. The incoming liquid forces the rotor to rotate. A magnetic coupling transmits the rotor rotations to a mechanical or LCD counter and/or to an optional pulse transmitter. The pulse transmitter allows remote flow monitoring or process control.



Note:

These flow meters are subject to P.E.D. (Pressure Equipment Directive) cat 3.3.

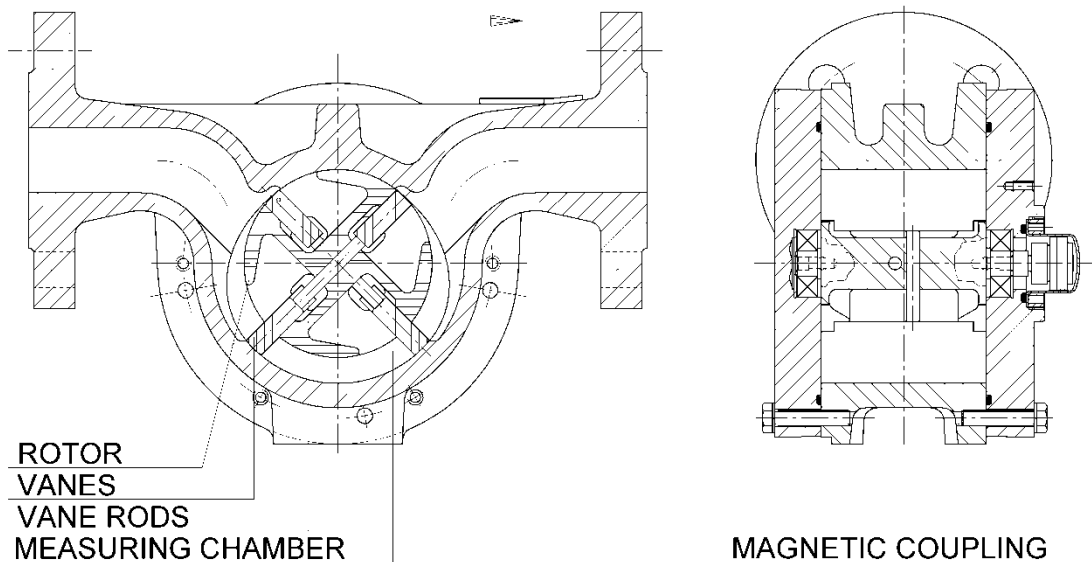

Figure 1 Sectional view of VAF vane meter

3. TECHNICAL SPECIFICATIONS

3.1 FLOWMETER

The technical specification of the flowmeter can be found on the instrument text plate.

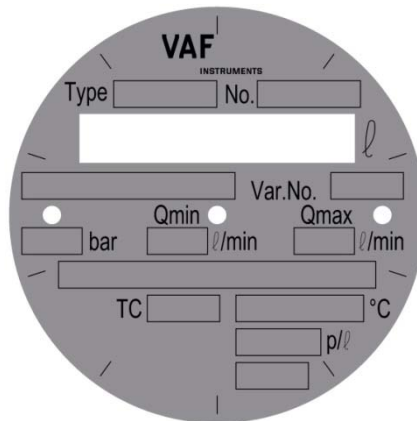

Figure 2 Text plate

3.2 OPTIONAL PULSE TRANSMITTER

If the flowmeter is equipped with a totaliser, the internal connections of the cable connected to the flowmeter are as shown in figure 8. The number of generated output pulses/litre is stamped on the text plate of the totaliser.

If the flowmeter is equipped with a pulse transmitter box (instead of a totaliser), the number of generated output pulses is stamped on the text plate of the pulse transmitter box.

See figure 7 to 11 for connection diagrams.

3.2.1 Technical specification of pulse transmitters

Inductive type: 1 or 2 passive proximity switches according DIN 19234 (NAMUR). Protection class IP55, intrinsically safe acc. PTB No. 99 ATEX 2219X and Cenelec Eex ia IICT6..T4, if used with suitable zener-barrier. Max. operating temperature 75°C. Supply voltage 8.2 VDC.

Incremental type: Installed in a pulse box fitted to the flow meter. Includes pulse discriminator. Supply voltage 12-35 VDC. Max frequency 5 kHz. Protection class IP55. Max. operating temperature 55°C.

3.2.2 Intrinsic safe operation

To meet the standards for intrinsically safe operation according DIN 19234 (NAMUR), zener-barrier(s) (Stahl 9001/3-158-150/00, Pepperl & Fuchs EGT-101-0, or equivalent) must be installed between the flow meter and the associated data processing instrumentation. Consult VAF Instruments if further information on zener-barriers is required.

3.3 OPTIONAL PULSE DISCRIMINATOR

The pulse discriminator is housed in the pulse transmitter box of a non-indicating flowmeter. The discriminator is used in situations where, as a result of vibrations or pulsations in the liquid piping, it is possible for the flowmeter to rotate in the reverse direction. This may result in the generation of spurious pulses by the electric transmitter. By using a double pulse transmitter in the flowmeter, generating two identical pulse signals with a phase shift of 90 degrees, these measurement errors will be eliminated by means of the pulse discriminator. The discriminator comprises a small printed circuit board which also contains a pulse amplifier. This makes the device suitable for direct connection to, for instance, an electromechanical counter or to a relay for further pulse processing.

3.3.1 Technical specifications of the pulse discriminator

| | |
|-----------------------|---|
| Electric connections: | 3-wire screw terminal |
| Supply voltage: | 12-35 VDC |
| Power consumption: | 2 VA at 35 VDC (no load) |
| Input signal: | 2 NAMUR pulse transmitters or incremental encoders |
| Pulse memory: | up to 15 error pulses |
| Connections: | 6-pin connector or cable gland PG 13.5 |
| Max. working temp: | 55°C |
| Output signal: | Open collector, current sink . I_{max} 100 mA, U_{max} 35 VDC |
| Protection class: | IP55, DIN 40050 |
| Approved: | CE |

3.4 LIQUID FILTER

The liquid to be measured must be clean and free from air, gas or dirt. Solid particles may cause excessive wear. It is recommended to install a VAF liquid filter with a mesh width of ... 0.05 mm (280 mesh) at the inlet of the flowmeter. If necessary also install a suitable deaerator. Refer to product bulletin 302 for more information.



VAF Instruments will not be responsible for any damage to flowmeters and accessories caused by foreign particles in the process liquid.

3.5 WEIGHT OF FLOWMETERS AND COUNTERS

Weight including counter

| Model No | Approx. net weight (kg) |
|----------|-------------------------|
| B5015 | 5 |
| B5023 | 7 |
| B5025 | 12 |
| B5040 | 14 |
| B5050 | 22 |

4. SAFETY INSTRUCTIONS

- Some calibration fluid can be left in the flowmeter. This is Q8 Induco 4 (Q8 Puccini 4P) See chapter 6.4 for more information.
- Be careful, the flowmeter can be heavy, and difficult to handle with one person.

5. UNPACKING

The flow meter is a precision instrument and should be treated with care.

The two yellow protection caps on the in and outlet of the meter should be left in place as long as possible

Be careful not to put any force on the electrical connection box.

6. INSTALLATION AND FIRST USE

6.1 BEFORE INSTALLING FLOWMETER

1. Identify your flowmeter by comparing the type number on the instrument text plate with the description on the packing list.



Always quote type and serial numbers when contacting the factory.

2. Record data on text plate of flowmeter in the space below, by filling in the text plate (figure 3).
3. Ensure that the flowmeter is suitable for your process conditions.



Never exceed the capacity, temperature and pressure limits specified on the nameplate of the flowmeter. Consult the factory if the flowmeter must be used for a different process liquid than originally ordered.

4. Store the flowmeter in a safe place. Do not remove dust caps until just before installation.

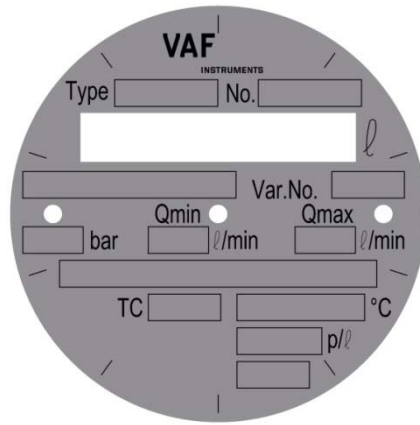

Please fill in the details of your flowmeter here.

Figure 3 Text plate on flowmeter body

6.2 GENERAL



Read this section carefully before starting the installation work.

1. A VAF flowmeter is a precision instrument. Handle it with care.
2. No special tools are required to install the flowmeter. Ensure that your standard tools are fit for the job.
3. Use the lifting eye, when present, when moving the flowmeter.
4. Make sure the working environment is clean. Ensure that no dirt can enter the flowmeter.
5. Always use personal protective means when working with hot, aggressive and toxic process liquids.
6. Ensure that local safety regulations are met when installing and operating the flowmeter.
7. The sound level of a working flowmeter will always be lower than 70 dB(A).

6.3 SYSTEM LAYOUT RECOMMENDATIONS



Warning

The flowmeter body will maintain the same temperature as the process liquid. Take measures to avoid personal injury from touching a hot or cold flowmeter. When applying insulation, do not apply this onto the read out counter, but only onto the flowmeter body.

Vibrations and pulsations must be avoided at the position of the flowmeter to ensure trouble free operation of the instrument.

6.3.1 Supporting the flow meter

The flowmeter must never be used to support the piping or other system components. The flowmeter and its connecting flanges must be protected against strain or mechanical vibrations. Either the flowmeter must be supported by the process piping, or both the pipeline and the flowmeter must be supported.

1. Install suitable pipe brackets at each side of flowmeter (Figure 4).



The flow meter should be accessible from all sides for easy inspection and servicing.

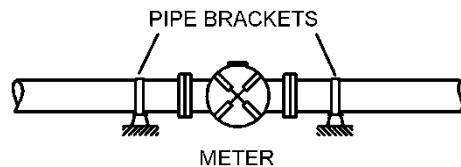

Figure 4 Supporting the flowmeter

6.3.2 Bypass piping arrangement

A bypass with manual block valves is recommended so that the meter can be serviced without interrupting the flow in the system (Figure 5).



A bypass may not be allowed when the flowmeter is used for custody transfer purposes.

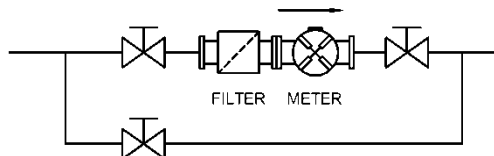

Figure 5 Bypass piping arrangement

6.3.3 To prevent the flowmeter from emptying

To prevent the flowmeter from emptying or siphoning, maintain a back-pressure downstream of the meter so that it always remains full of liquid. This can be done by raising the pipe line downstream of the flowmeter, by installing a back-pressure valve or by other suitable method.

6.3.4 To prevent measuring air

Accurate measurement is only possible if it is not influenced by the presence of gas or air. When the process liquid contains gas or air a deaerator should be fitted upstream of the flowmeter.

6.4 TO INSTALL FLOWMETER

1. Remove dust caps from inlet and outlet connections of flowmeter.



Note that some Q8 Induco 4 (Q8 Puccini 4P) calibration liquid may be left in the flowmeter.

Q8 Induco 4 (Q8 Puccini 4P) is a refined mineral oil; EG No. 265-158-7, CAS No. 64742-55-8.

2. Install flowmeter to process piping in accordance with the relevant figure 6.

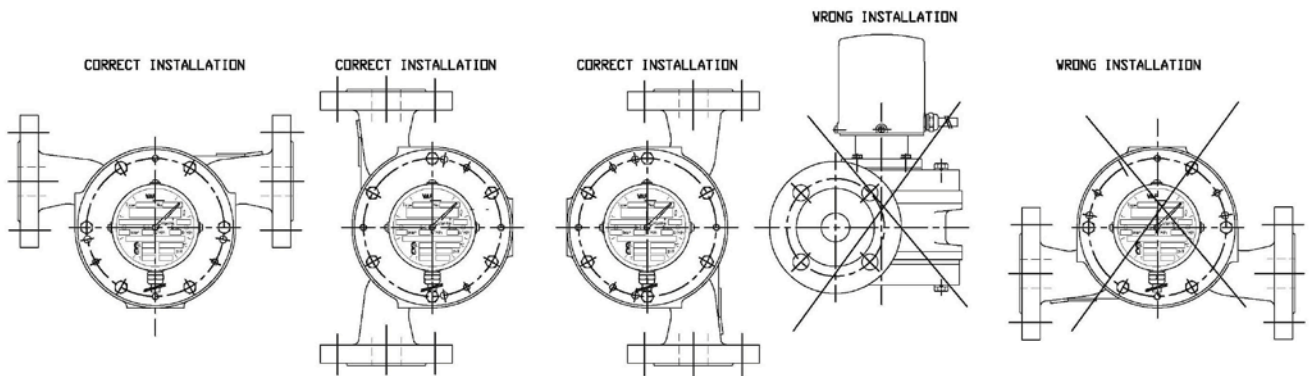

Figure 6



Note that:

- the back cover of the flowmeter must always be in vertical position.
- an arrow on the flowmeter body indicates the direction of the flow.
- the counter may be turned in 90° increments to facilitate reading.
- do not mount any object onto the flowmeter body

6.5 ELECTRIC CONNECTION DIAGRAMS

The electrical connections of the pulse transmitter are as shown in figures 7 through 11.

For electrical connections between flowmeter and associated electronic processing instrumentation, reference is made to the separate technical manuals supplied of these electronic instruments.

6.5.1 Connection cables

Each pair of leads between the pulse transmitter and the connected signal processing instrumentation must be screened separately, as otherwise false pulses might be induced by external electromagnetic fields.

Use shielded cable with a diameter of 6 to 8 mm and a wire diameter of max. 0.8 mm. The screen must NOT come into contact with the flowmeter. In the connected instrument the screen must be connected to the system earth or, in absence of the latter, to the zero connection of the pulse input terminals.

6.5.2 Connections at totaliser

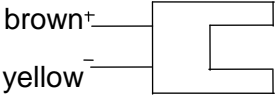
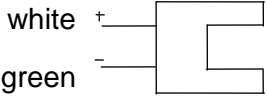
| | | |
|--|--|---|
| Wiring of pulse generators: |  |  |
| Connections of pulse transmitter: | | |
| 1 low frequency pulse transmitter * | low: λ | |
| 1 high frequency pulse transmitter | | high: λ |
| 1 low + high frequency pulse transmitter | low: λ | high: λ |
| 2 low frequency pulse transmitters * | low: λ | low: λ |
| 2 high frequency pulse transmitters | high: λ | high: λ |

* Low frequency includes 1 & 5 & 10 pulses/litre (meter models B5015, B5023, B5025, B5040) and 0.1 & 0,5 & 1 pulse/litre (meter model B5050). Other pulse rates are high frequency type.

Figure 7 Wiring of pulse generators inside totaliser

6.5.3 Connections at 6-pole connector

When the pulse output cable from the totaliser is provided with a 6-pole connector, the internal wiring is as shown in figure 8.

| | 6-pole connector | Cable |
|--------|------------------|----------|
| High 1 | + | A White |
| | - | B Green |
| High 2 | + | C Brown |
| | - | D Yellow |
| Low 1 | + | E Brown |
| | - | F Yellow |
| Low 2 | + | C White |
| | - | D Green |

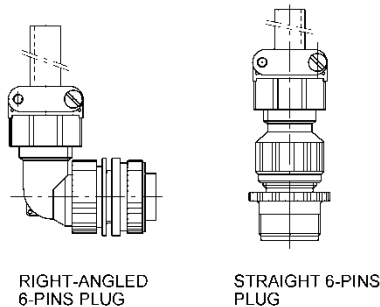

Figure 8 Internal wiring of connector plug

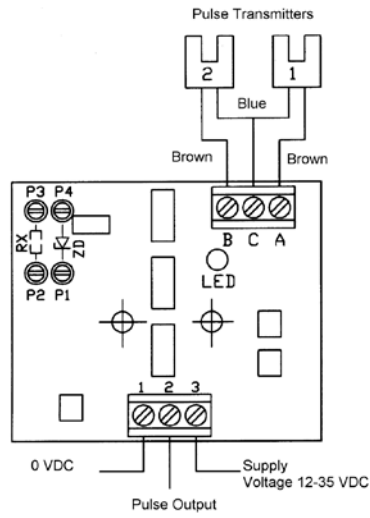
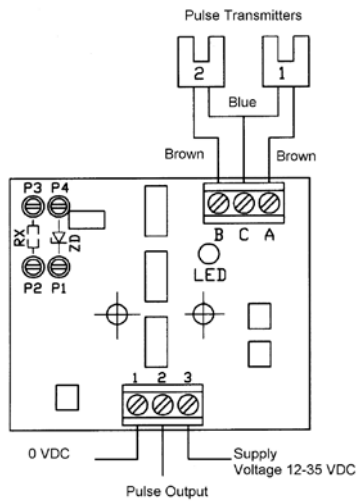

Figure 9 External connections of flowmeter with pulse discriminator or incremental pulse encoder in pulse box with Pg 13.5 cable gland

6.5.4 External connections at pulse transmitter box



| Pulse output | Resistor (Rx) | Zener diode (Zd) |
|----------------|---------------|------------------|
| Open-Collector | - | - |
| 5 V pulse | * 2k4 | 4V7 - 0,4 W |
| 12 v pulse | * 1k4 | 12 V - 0,4 W |

* supply voltage 24 VDC

$$\text{Calculation: } R_x = \frac{\text{supply voltage} - \text{desired pulse voltage}}{0,008}$$

Figure 10 Non-indicating flow meter with inductive pulse transmitters and pulse discriminator

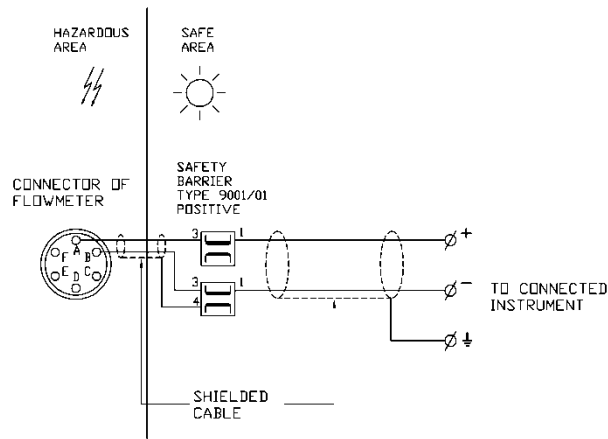

Figure 11 External connections to safety barrier

7. OPERATING INSTRUCTIONS

7.1 START-UP PROCEDURES

Before initial start-up of a flowmeter system, or when taking the installation again into use after a major repair or revision of the piping system, the following procedures are recommended.

1. Remove filter element of liquid filter installed ahead of flowmeter.
2. Remove flowmeter from liquid system and replace it by a pipe piece.
3. Flush entire liquid system to ensure that all dirt and other foreign matter that could damage the flowmeter have been removed.



CAUTION

- Do not flush ductile iron and steel flowmeters with water.
- NEVER exceed maximum flowrate (Q_{max} , see textplate of flowmeter)
- When re-starting the flowmeter measures must be taken to avoid the presence of solidified or cured liquids inside the flowmeter. Failure to do so may result in breaking of the magnet or magnet shaft.

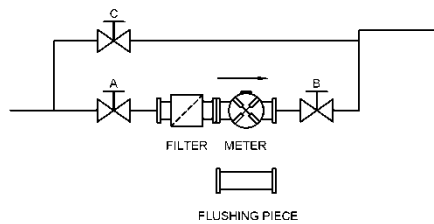

Figure 12 Flowmeter system with bypass

7.1.1 Initial start-up of a flowmeter system with bypass

1. Close valves A, B and C (Figure 12).
2. Remove flushing pipe piece. Re-install flowmeter and filter element.
3. Slowly open bypass valve C completely.
4. Start pump and/or open storage tank valve.
5. Open valve A slightly (5-10%).
6. Slowly open valve B. Dependent on the internal resistance in the system, the flowmeter may start running. If it does, limit the flow to approx. 20% of its capacity.
7. Slowly close bypass valve C until flow meter just starts running. Let the flowmeter run on this limited flow for a couple of minutes, to ensure that no air or gas will be left in the flowmeter.
8. Slowly open valve A, and if necessary also valve B, completely.
9. Slowly close valve C completely.

7.1.2 Initial start-up of a flowmeter system without bypass

1. Close valves A and B (Figure 13).
2. Remove flushing pipe piece. Re-install flowmeter and filter element.
3. Start pump and/or open storage tank valve.
4. Open valve A slightly (5-10%).
5. Slowly open valve B until flowmeter just starts running. Let the meter run on this limited flow for a couple of minutes, to ensure that no air or gas will be left in the flow meter.
6. Slowly open valve B completely.
7. Slowly open valve A completely.

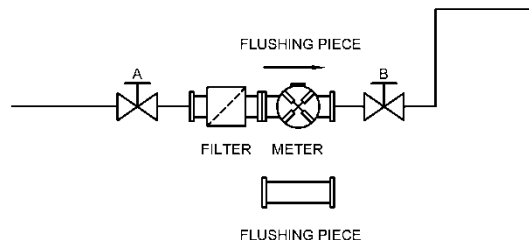

Figure 13 Flowmeter system without bypass

7.2 OPERATION OF COUNTERS

This section only contains concise operating procedures. For additional functional description of counters separate technical manuals can be ordered from VAF Instruments.

7.2.1 Totaliser

The totaliser requires no operation.



Figure 14 Totaliser

7.2.2 FlowCount Rate-Totaliser



Figure 15 FlowCount Rate Totaliser

The Model E200 FlowCount Rate Totaliser is fully programmed in the factory, in accordance with the flow data supplied by the customer. The instrument will display rate, resettable total and accumulated total.

FlowCount is an indicating instrument and may optionally be equipped with a 4-20 mA output, or a DC power input and flow alarm.

1. The accumulated total is displayed by pressing the [ACCUM TOTAL] key.
2. The resettable total can be reset at any time by pressing the [RESET] key.
3. The flow rate is continuously displayed.

The instrument also has a display test mode which can be entered by simultaneously pressing all three front panel keys, followed by pressing the [PROGRAM] key. All segments of the display will then show.

To exit the test mode, press the [ACCUM TOTAL] key and while still holding, simultaneously press the [RESET] and [PROGRAM] keys.



A technical manual with more details is supplied with each instrument.

8. MAINTENANCE

8.1 GENERAL

Under normal operating conditions the flowmeter requires no maintenance other than:

* Periodic accuracy check. Refer to section 8.2;



For flowmeters that are running continuously, we recommend to inspect bearings every year as a preventive measure to keep the flowmeter in the best possible condition. In case of damage or wear, they should be replaced.

* Check of totaliser (if this option is supplied). Refer to section 8.3.

8.2 ACCURACY CHECK

The calibration interval will depend on the nature of the process liquid and the operating conditions.

The table below applies if:-

* the process liquid is clean and non-abrasive;

* a liquid filter with correct mesh width has been installed at the flow meter inlet.

| Meter type | Calibration interval (litres) |
|------------|-------------------------------|
| B5015 | 11×10^6 |
| B5023 | 11×10^6 |
| B5025 | 35×10^6 |
| B5040 | 55×10^6 |
| B5050 | 110×10^6 |

8.3 CHECK OF TOTALISERS

The totaliser should be inspected:

* Every two years.

* Every year when the flow meter is installed in a hot, humid or dusty environment.

To check counter:

1. Remove three cross head screws and lift off cap.

2. Inspect gear train for wear.



Take care not to damage any pulse generators. Do not lubricate plastic parts.

9. SERVICE AND REPAIR INSTRUCTIONS

9.1 GENERAL

This chapter describes the procedures to be followed when a flowmeter must be removed from the process line for service or repair.

9.2 TO REMOVE FLOWMETER FROM PIPING SYSTEM



When removing a flowmeter from the piping system precautions must be taken to prevent personal injuries and damage to the flowmeter and process control installation.

- * Always wear protective clothing when the flowmeter contains a toxic or aggressive fluid.
- * Use a hoist or other lifting device and the lifting eye on top of the flowmeter to support the flowmeter when removing from the process piping.

9.2.1 General procedure

1. Shut off flow through flowmeter.
2. Remove any electrical connections from flowmeter. Record connections, if necessary.
3. Empty piping system, in accordance with chapter 9.2.2.
4. Drain flowmeter, in accordance with chapter 9.2.3.
5. Remove flowmeter from piping system, as described in chapter 9.2.4.

9.2.2 To empty piping system



Emptying a piping system is often done by blowing through with steam or air. This practise is not recommended when a vane type flowmeter is installed, because it will be overspeeded.

9.2.3 To drain flowmeter

1. If the flowmeter is fitted with a drain plug, remove plug to empty flowmeter.
2. When the flowmeter is not fitted with a drain plug, remove flowmeter as described under chapter 9.2.4.

9.2.4 To remove flowmeter from piping system

1. Ensure that flow through flowmeter has been shut off. Ensure that electric connections have been removed.



Although the flow has been shut off, the flowmeter can still be under pressure.
Be careful when loosening bolts on inlet and outlet flanges.

2. Use a lifting device and the lifting eye on top of the flowmeter to hold flowmeter in position.
3. Remove flowmeter from piping system.



When the flowmeter has been removed from the piping system there will still be some liquid left in its measuring chamber.

4. Hold meter outlet in downward position and let flowmeter leak out for approximately ten minutes. High viscosity liquids will perhaps require more time. Rinsing with a suitable solvent may be of help.
5. Place flowmeter on a dry and clean workbench.
6. If flowmeter must be returned to VAF Instruments or local service representative, follow instructions under chapter 12

9.3 DISMANTLING

The following procedures are recommended if the flow meter must be dismantled for overhaul or repair. Certain procedures require the use of accurate measuring tools. If these tools are not available it is advisable to return the flowmeter to VAF Instruments or local service representative.

9.3.1 To remove flowmeter from liquid piping

Follow instructions on paragraphs 9.2.1 through 9.2.4.

9.3.2 To remove counter from flowmeter

Remove pulse box (figure 16), or counter (figure 17) from meter body according the following procedure:

1. Loosen 4 bolts M4 x 12
2. Rotate outer magnet with finger (Figure 18) and check shafts, calibration gears and bearings for wear and excessive slackness of the counter drive.
3. Ensure that the outer magnet is clean and that none of the magnets are missing or damaged. Check centering of outer magnet.



Figure 16



Figure 17



Figure 18A N-counter



Figure 18B Pulse box

9.3.3 To remove magnet cap and magnet

1. Remove magnet cap holder by loosening the nut (figure 19)
2. Remove magnet cap, inner magnet and sealing ring, as shown in figures 20, 21 and 22
3. Check inside of magnet cap and outside of inner magnet for grooves. If any grooves are found, the magnet shaft is probably bent and must be replaced. Replace the magnet cap if too heavily grooved.



Figure 19

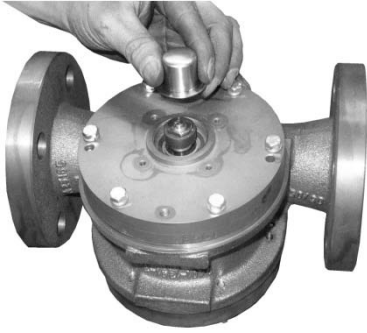

Figure 20



Figure 21

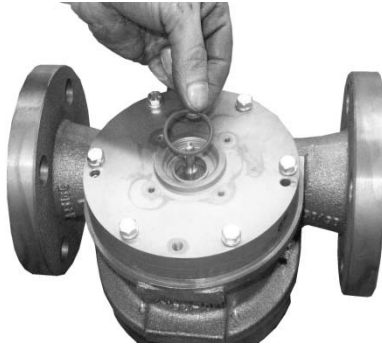

Figure 22

9.3.4 To remove front cover

Register the flowdirection before dismantling the flowmeter. Look from counter side to arrow marked at the flowmeter for flow direction. Note: standard flow direction is left to right.



Figure 23 Flowdirection left to right

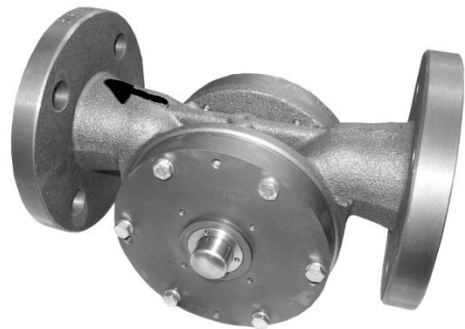

Figure 24 Flowdirection right to left

Check for any signs of bearing wear by 'wiggling' flow meter shaft carefully.

1. Remove the front cover mounting bolts and lock washers (figure 25)
2. Install the bolts, which were removed in step 1 above, in the jacking positions of the front cover (figure 26). Tighten these bolts evenly and alternately until the cover frees. Ensure cover is lifted equally to protect the location pins from being damaged.
3. Lift off cover equally to protect the location pins from being damaged and remove bolts and O-ring (figure 27) Visually inspect inside surface and bearing cavity for grooves and other signs of wear, indicating that bearing(s) or vanes are damaged.



Do not remove the pin glued in the cover while it is used for centering the cover, refer to figure 27.



Figure 25



Figure 26



Figure 27 Center pin location

9.3.5 To remove rotor/vanes assembly

1. Before taking the rotor out of the meter body, visually inspect the inside of the body to locate possible cause of damage. If the vanes appear to be broken, ensure that the vane push rods will not scratch against the inner wall of the meter body, when the rotor is pulled out (fig 28).
2. Record how vanes are installed in the rotor (figure 29). Remove rotor from body by gently pulling at the rotor shaft and supporting the rotor/vane assembly with the other hand (figure 30)



Figure 28

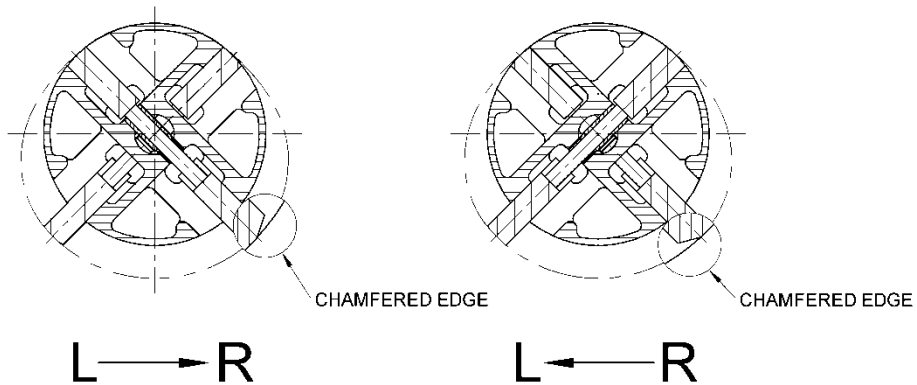

Figure 29

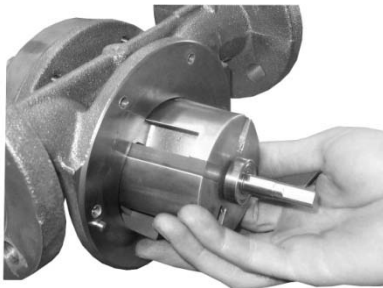

Figure 30



Caution:

Be careful not to drop or damage the four loose vanes and the two loose vane push rods when removing the rotor from the meter body. Keep both pairs of vanes together.

9.3.6 To remove back cover

1. Remove the back cover mounting bolts and lock washers (figure 31)
2. Install the bolts, which were removed in step 1 above, in the jacking positions of the back cover (figure 32). Tighten these bolts evenly and alternately until the cover frees. Ensure cover is lifted equally to protect the location pins from being damaged.
3. Lift off cover and remove bolts and O-ring (figure 33). Visually inspect inside surface and bearing cavity for grooves and other signs of wear, indicating that bearing(s) or vanes are damaged.

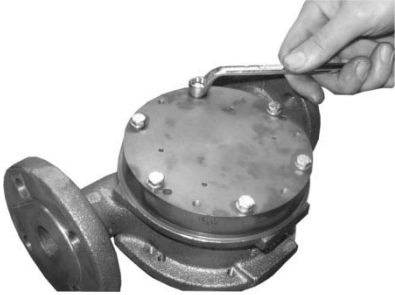

Figure 31



Figure 32



Figure 33

9.3.7 To inspect inside of meter body

1. Visually inspect inner surface of meter body for grooves. Minimal grooving due to small impurities in the process liquid requires no further action, provided that the original shape of the metering chamber is not disturbed. Grooving caused by coarse particles in the process liquid, or by a vane push rod when a vane is broken, will upset material. Such obstructions may result in uneven running of the flow meter and/or premature vane wear affecting the performance of the flow meter.
2. Remove any surface roughness with fine emery cloth.



If the meter wall was heavily scored no guarantee can be given that after polishing action the flowmeter will still be able to operate within its specified limits of accuracy.

3. Degrease meter body in a suitable solvent.

9.3.8 To inspect rotor and vanes

1. Visually inspect for chipped vanes, replace vanes if necessary.
2. Measure the height of vanes. Replace vanes if height is less than height of rotor.
3. Measure the vane/slot clearance using a feeler gauge (fig 34). For correct measurement the gauge must be bottomed out in the slot. If the tolerance shown below is exceeded, the vane(s) must be replaced.

| Meter model | Standard vane - slot clearance [mm] |
|--------------|-------------------------------------|
| B5015 (1/2") | 0.040 - 0.050 |
| B5025 (1") | 0.040 - 0.070 |
| B5040 (1,5") | 0.040 - 0.070 |
| B5050 (2") | 0.045 - 0.080 |

4. Check that the vane at vane rod side is not damaged causing too much space between vanes and meter body.
5. Check that the vane rods can slide freely in and out of the rotor. If the rods cannot move freely this may be caused by dirt, worn out bores, bent push rods or scored vanes. Any defective parts must be replaced.



Figure 34

9.3.9 To inspect bearings and rotor shaft

1. Visually inspect bearings, bearing cages, bearing cavities in covers and rotor shaft for excessive wear or other damage. The maximum run out tolerance for rotor shafts is 0.01 mm dial gauge reading.
2. Replace defective bearings in accordance with section 9.4.12.

9.3.10 To replace bearings

1. Remove old bearing from rotor shaft using a suitable bearing puller (Figure 35).



Because the space between bearings and rotor is approximately 2 mm, this operation requires a puller with thin blades.

2. Press new bearing vertically on rotor shaft using an arbor press.



Figure35

9.4 TO RE-ASSEMBLE A FLOWMETER

9.4.1 General

1. If there is any doubt about the condition of a particular flowmeter component, replace it when the meter is still dismantled. This is more economical than having to strip the flowmeter down again after a short period of time.
2. Once the flow meter has been dismantled it is recommended that the O-rings for the covers and the O-ring for the magnet cap are replaced.
3. Metal and carbon parts must be degreased before assembly. O-rings should only be wiped dry with a clean cloth.

9.4.2 To install back cover

1. Clean O-ring groove and install new O-ring (Figure 36).
2. Position back cover over locating pins of meter body.



Take utmost care not to damage the locating pins. Ensure that the O-ring remains in place and is not damaged while tapping down cover.



Figure 36

3. Install cover to meter body using bolts (and lock washers if originally provided). Lubricate bolt threads with 'Never Seez'. Tighten bolts alternately and evenly to the torque value specified on next page.

Torque values (Nm) – Covers

| Meter Model | No. Of bolts | Stainless Steel | Steel | Ductile iron |
|-------------|--------------|-----------------|-------|--------------|
| B5015 | 6x M6 | - | - | 8.5 - 9 |
| B5025/B5040 | 6x M6 | - | - | 8.5 - 9 |
| B5050 | 6x M8 | - | - | 16 - 17 |

To install rotor and vanes

1. Place the two vane push rods through the drilled and reamed holes in the rotor (Figure 37).
2. Place rotor with installed vane push rods into flow meter body, with magnet shaft facing up (Figure 38).



Take care not to damage the bearing in the back cover.

3. Place two opposite slots in rotor in line with inlet and outlet flange connections of flowmeter.



Figure 37

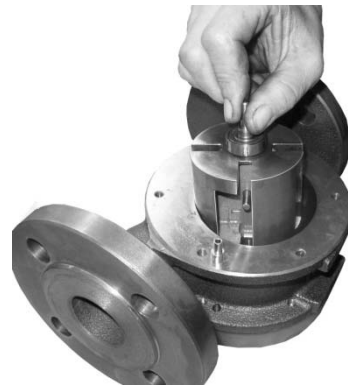

Figure 38

4. Insert the four (4) vanes one by one into the slots of the rotor, starting with the vane nearest to the inlet connection. Continue with the opposite vane. Then rotate the rotor 1/4 turn and insert the other vanes in the same order (Figure 39). The chamfered edge of each vane must be in the rotating direction of the rotor, as shown in Figure 40 for flowmeters with flow direction from left to right and from right to left. The top of the vanes must be flush with the upper surface of the rotor.



Take care not to damage the vanes.

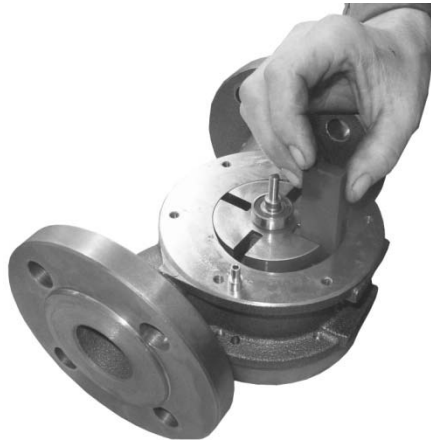

Figure 39

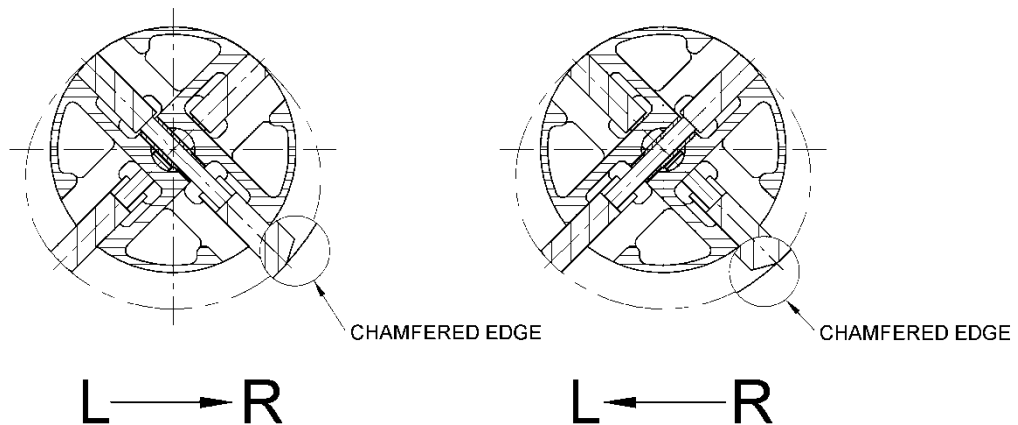

Figure 40

5. Measure the radial vane clearance with a feeler gauge. Measurement should be taken as shown in Figure 41. For correct measurement the gauge must be bottomed out in the slot. If the tolerance is in excess of the value mentioned in the table on next page, replace vane(s) or grind to size with fine emery cloth.

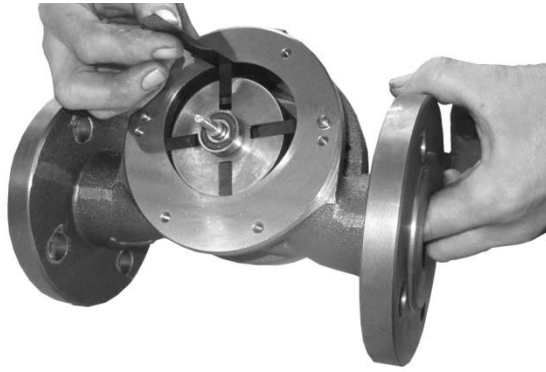

Figure 41

Vane-to-meter body clearance

| Model No. | Tolerance (mm) |
|--------------|----------------|
| B5015 (1/2") | 0.025 - 0.060 |
| B5025 (1") | 0.040 - 0.090 |
| B5040 (1.5") | 0.040 - 0.090 |
| B5050 (2") | 0.050 - 0.100 |

6. Rotate the rotor with finger to ensure that it will run smoothly.

9.4.3 To install front cover to meter body

1. Clean O-ring groove and install new O-ring.
2. Tilt meter body, so that the rotor shaft is in horizontal position.
3. Position front cover over locating pins on meter body.



When installing front cover to meter body take utmost care not to damage bearing and locating pins. Ensure that the O-ring remains in place and is not damaged.

4. Lubricate threads of cover mounting bolts with 'Never Seez'. Install bolts (and lock washers if originally provided). Tighten bolts equally and in turn (Figure 42), in accordance with the torque value table of section 9.4.2.

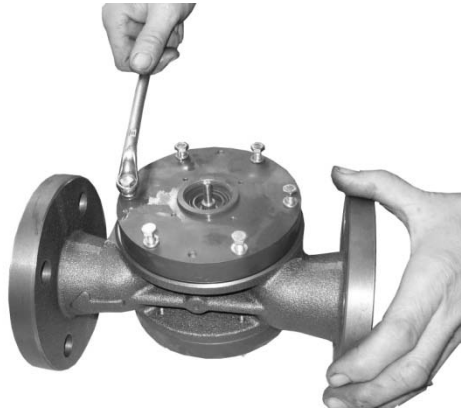

Figure 42

9.4.4 To install inner magnet

1. Place inner magnet on rotor shaft (Figure 43). The magnet should be placed as shown in figure 44. The magnet must be flush with the shaft.
2. With the rotor shaft in horizontal position, rotate the rotor shaft by hand using the magnet, to check that the rotor runs smoothly.



Figure 43

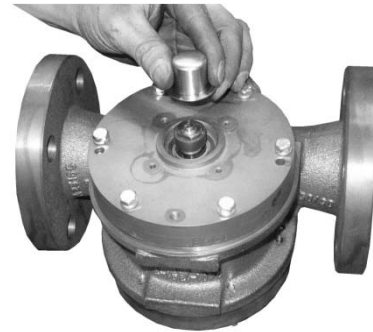

Figure 44

9.4.5 To install magnet cap

1. Clean O-ring groove in front cover and install new O-ring (Figure 45).
2. Clean inner magnet with compressed air.
3. Place magnet cap over magnet (Figure 46)

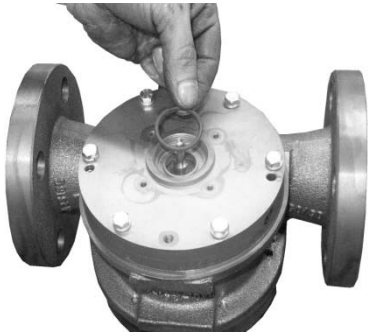

Figure 45

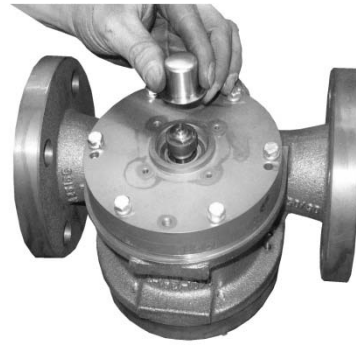

Figure 46

5. For a final check that the rotor runs smoothly after assembling covers and magnet cap, the flowmeter may be blown through with compressed air at **low** pressure. The rotor must then be able to make a few obstructionless rotations. If the rotor does not run smoothly, disassemble the flowmeter and repeat the assembly procedures.



Extreme care should be taken not to overspeed the rotor to avoid damage to the internal meter parts. Just apply enough air that the rotor starts running.

9.4.6 To install pulse transmitter box or counter

Clean out magnet of pulse transmitter box/counter.

Install the pulse transmitter box/counter by placement of the four bolts M4x12 (Figure 47).



The pulse transmitter box must be installed in such a way that, when the flowmeter is installed in the liquid piping, the cable gland will point downwards or side wards, but never upwards.



Figure 47

9.5 FINAL PERFORMANCE CHECK

If the flowmeter is recalibrated during a maintenance check or after replacement of major parts, the highest measuring accuracy should be within the operating flow range of the flowmeter.

9.6 CHANGING THE FLOW DIRECTION

Unless otherwise specified VAF Series ProFlow meters are delivered for a flow direction from left to right.

When the flow direction must be changed from left-to-right into bottom-to-top or top-to-bottom, this can easily be done by removing the mounting bolts of the counter or pulse transmitter box and rotate it 90 degrees clockwise or counter clockwise (Figure 48). Note that in all cases the flowdirection of the flowmeter, pointed out by the marked arrow on the meter body, is in the right direction.

If for some reason the direction of flow must be reversed from left-to-right into right-to-left please contact VAF Instruments or local service agent.



If the change in flow direction must be made during the warranty periods contact the factory or your local VAF Instruments distributor, because unauthorized servicing will void the warranty.



If a change in flow direction is made, the code number as stamped on the identification plate of the flowmeter is no longer valid. Therefore please keep record of the changes to avoid difficulties when ordering replacement parts.



Figure 48 Flowdirection top to bottom



Figure 49 Flowdirection bottom to top

10. TAKE OUT OF SERVICE

If the flowmeter has to be taken out of service follow the instructions in chapter 9 (repair) to remove the flowmeter from the system. Flush the flowmeter with a clean non corrosive fluid, like light diesel oil, or kerosene. The flowmeter should than be emptied as much as possible. The inlet and outlet must be closed off to prevent dirt or other particals entering the flowmeter. This can damage the flowmeter.

11. REMOVAL AND STORAGE OF EQUIPMENT

Follow the instruction in chapter 9 (repair) to remove the flowmeter from the system. Flush the flowmeter with a clean non corrosive fluid, like light diesel oil, or kerosene. The flowmeter should than be emptied as much as possible. The inlet and outlet must be closed off to prevent dirt or other particals entering the flowmeter. This can damage the flowmeter. It should be stored and secured in a save place. If the flowmeter is stored for a longer period of time, it should be treated inside with a corrosion prevention liquid.

12. MALFUNCTION AND SEND FOR REPAIR

In case the flowmeter stops working and cannot be repaired on site, it should be send back for repair. Follow the instructions in Chapter 11 (Removal and storage of equipment).

The shipping container or wooden box must be strong enough to protect the flow meter during transport.

The flowmeter should be packed with soft material to protect it against shock's.

A fault report should accompany the flowmeter, stating the fault, which fluid the meter was used for and all other information that is important to speed up the repair.

Example of sheet to accompany a return shipment to factory or service agent.

Sheet to be filled out in English language

| | |
|--------------------|----------------------|
| Sender | |
| Company Name _____ | Contact Person _____ |
| Street _____ | Department _____ |
| Postal Code _____ | Telephone _____ |
| City _____ | Fax _____ |
| Country _____ | E-mail _____ |

Shipping address for return of goods to user (if different from above mentioned)

Reason for return

Repair Warranty Claim Calibration

Other _____

Type of flow meter (see nameplate on instrument)

Code / Type: _____

Serial Number: _____

Liquid Data

Process Liquid (trade name or chemical composition): _____

Liquid properties:

harmless toxic explosion dangerous inflammable

Flow rate [l/min] minimal _____ nominal _____ maximum _____

Operating pressure: _____ Operating temperature: _____

Specific gravity: _____ Viscosity: _____

Description of Complaint / Work to be performed

Safety Precautions

The flow meter has been emptied

The flow meter has been internally cleaned and preserved using _____

Inlet- and outlet ports have been plugged

Recommended cleaning fluid: _____

Recommended safety precautions before opening of flow meter: _____

| | |
|--------------------------|---------------------|
| Installation date: _____ | Failure date: _____ |
| Date & Signature _____ | Name & Title: _____ |
| _____ | _____ |

13. ENVIRONMENT

The flowmeter has no negative influence on the environment it is placed in.
The noise the meter is producing in normal circumstances is below 70 dB (A).

14. DISPOSAL

Laws and restrictions for disposal of equipment will be different in most countries. If in doubt or unable to dispose the equipment it can be send back to VAF Instruments.
VAF Instruments will dispose the equipment in a correct way.

Main materials:

| | |
|-------|--------------|
| Body | Ductile iron |
| Rotor | Ductile iron |
| Vanes | Carbon |

15. TROUBLE SHOOTING

15.1 TROUBLE SHOOTING CHART

Problem:

The flowmeter does not indicate any flow, although the liquid is flowing.

Possible cause

Solution

(perform a check in the following order):

1. The valve in the bypass line is still open

Close bypass valve.

2. The totaliser or FlowCount Rate-Totaliser is malfunctioning.

Totaliser:
Remove counter drive shaft with finger to see if counter runs smoothly.

FlowCount: Is battery empty?
Refer to trouble shooting section of manual supplied with instrument.
Continue with next step if this does not solve the problem.

3. Inner parts of flow meter may be stuck or broken.

Return flowmeter to factory or authorized local VAF Instruments service representative.

Problem:

The flowmeter does not indicate any flow and no liquid is passing through the flowmeter.

Possible cause:

Solution:

(perform a check in the following order):

- | | |
|--|--|
| 1. Obstructions in the liquid piping, blocking the flow. | Check for obstructions, e.g. closed valves. If this does not solve the problem, proceed with next step. |
| 2. The dust cap in the inlet and/or outlet connection of the flowmeter was not removed when the flowmeter was installed in the process line. | Remove dust cap(s) and check the flowmeter for damage. If there are no visible signs of damage, proceed with next step. |
| 3. Dirt is blocking the inner parts of the flowmeter. | Flush the flowmeter with a suitable solvent. If this does not solve the problem, return flowmeter to factory or nearest authorized VAF Instruments service representative. |
| 4. Inner parts of flowmeter may be stuck or broken. | Return flowmeter to factory or nearest authorized VAF service representative. |

15.2 CONDITIONS FOR RETURN OF GOODS

Return shipments of goods to VAF Instruments or local service agent must meet the following conditions:

1. The shipment must be accompanied by a check list giving full information about the reason for return and further instructions. See example on next page.
2. The flowmeter must be internally and externally cleaned and adequately preserved. It must be free from risks of fire, explosion and toxic matters which may cause a hazardous situation or personal injury.
3. Flowmeter inlet and outlet connections must be plugged so that no liquid can leak out of the instrument.
4. Goods must be sent c.i.f. destination.

16. CERTIFICATES

Certificates are delivered separately.

17. DRAWINGS

17.1 ASSEMBLY DRAWINGS AND PARTS-LISTS

LOCKED IN COVERS WITH LOCTITE TYPE 648

CROSS SECTION I-I CROSS SECTION II-II

SPARE PARTS KIT METER

| No | DRAWING No. | ITEM No. | | | | |
|--|-------------|-------------|----|----|----|----|
| | | 5 | 8 | 11 | 14 | |
| 2 YEARS WITH VITON O-RINGS AND STANDARD VANES | 0801-0813 | 0801-1292-4 | 1x | 2x | 1x | 1x |
| 2 YEARS WITH V/PFA O-RINGS AND STANDARD VANES | 0850-0814 | 0801-1294-4 | 1x | 2x | 2x | 1x |
| 2 YEARS WITH KALREZ O-RINGS AND STANDARD VANES | 0850-0805 | 0801-1294-4 | 1x | 2x | 2x | 1x |
| 5 YEARS WITH VITON O-RINGS AND STANDARD VANES | 0390-0815 | ----- | 1x | 2x | 2x | 2x |

FOR PARTS LIST METER SEE DRAWING 0801-2310-4

| METER WITH | DIMENSIONAL DRAWING | PARTS LIST | EXT. CONN. DIAGRAM |
|---|---------------------|-------------|--------------------|
| N-COUNTER | 0801-3125-3 | ----- | ----- |
| PULSE TRANSMITTER IN N-COUNTER | 0801-3125-3 | ----- | 0830-2013/4-4 |
| FLUORESCENT | 0801-1069-3 | 0830-1231-3 | 0830-2011-4 |
| PULSE TRANSMITTER BDX N=1 ... 25 | | 0879-1202-3 | 0830-2007-4 |
| PULSE TRANSMITTER BDX N=50 | | 0879-1215-3 | 0830-2007-4 |
| PULSE DISCRIMINATOR BDX N=1 ... 25 | 0801-1157-3 | 0879-1204-3 | 0830-2008-4 |
| PULSE DISCRIMINATOR BDX N=50 | | 0879-1219-3 | 0830-2008-4 |
| INCREMENTAL PULSE TRANSM. BDX (ULD) N=100/250/500 | | 0879-1211-3 | 0830-2009-4 |
| INCREMENTAL PULSE TRANSM. BDX (NFW) N=100/250/500 | | 0897-1223-3 | 0830-2008-4 |
| MAGNETIC PULSE TRANSMITTER BDX | 0801-1147-3 | 0890-1207-3 | 0801-8052-4 |

| | | |
|--------------|--|--|
| VAF | | DATE: 11-01-2019 |
| INSTRUMENTS | | DRAWN: 1 RPS |
| METER 05015D | | CHECKED: <input checked="" type="checkbox"/> |
| DN15 PN40 | | MATERIAL: DUCTILE IRON |
| WITH FLANGES | | GENE INT: - |
| PART OF: | | 0801-1344 |
| | | C REV |

C. LEED GEW. LAGE No. DESCRIPTION DATE PAGE CHECKING BY

THIS INFORMATION IS THE PROPERTY OF VAF INSTRUMENTS. IT MUST NOT BE REPRODUCED IN ANY MANNER, FORM, OR BY ANY MEANS, WITHOUT THE WRITTEN PERMISSION OF VAF INSTRUMENTS.

| ITEM No. | PART NUMBER | QTY | PART NAME | MATERIAL |
|----------|-------------|-----|--|----------------|
| 1 | 0417-0005 | 1 | NUT, MAGNET CAP M36x1.5, ID 22.8x6mm | AISI 316 |
| 2 | | 1 | ASSY, MAGNET | |
| | 0313-0004 | | STANDARD, $\varnothing 20.9 \times 15$ mm | FERROXDURE/ |
| | 0313-0019 | | FIXED, INCL. ITEM 17, $\varnothing 20.9 \times 15$ mm | AISI 316 |
| | 0313-0031 | | CLOSED, $\varnothing 20.9 \times 14$ mm | AISI 316 |
| | 0313-0045 | | CLOSED + FIXED, INCL. ITEM 17, $\varnothing 20.9 \times 14$ mm | AISI 316 |
| 3 | 0409-0026 | 1 | CAP, MAGNET, $\varnothing 22.6/\varnothing 34 \times 21$ mm | AISI 316 |
| 5 | | 1 | O-RING, ID 25.07 x $\varnothing 2.62$ mm | |
| | 0630-3120 | | STANDARD | VITON |
| | 0630-4120 | | OPTIONAL | VITON/PFA |
| | 0630-9120 | | OPTIONAL | KALREZ |
| 6 | 0302-0228 | 1 | COVER, FRONT, INCLUDING 1xITEM 11, $\varnothing 98 \times 20$ mm | DUCTILE IRON |
| 7 | | 1 | HOUSING, INCLUDING ITEM No. 16 | DUCTILE IRON |
| | 0401-0439 | | FLANGE, DIN PN10/16/25/40 | |
| | 0401-0440 | | FLANGE, ANSI CLASS 150RF | |
| | 0401-0441 | | FLANGE, ANSI CLASS 300RF | |
| | 0401-0583 | | FLANGE, JIS 5K | |
| | 0401-0442 | | FLANGE, JIS 10/16/20K | |
| 8 | | 2 | O-RING, ID 59.99 x $\varnothing 2.62$ mm | |
| | 0630-3142 | | STANDARD | VITON |
| | 0630-4142 | | OPTIONAL | VITON/PFA |
| | 0630-9142 | | OPTIONAL | KALREZ |
| 9 | 0302-0229 | 1 | COVER, BACK, INCLUDING 1xITEM 11, $\varnothing 98 \times 20$ mm | DUCTILE IRON |
| 10 | 0732-0670 | 4 | BOLT, HEX, HEAD. M6 x 70 mm, DIN 931 | STEEL 8.8 |
| 11 | 0604-0017 | 2 | BEARING, NEEDLE, OD 12 x ID 6 x 10 mm | STEEL |
| 12 | | 1 | ROTOR, ASSY, OD 42/6 x 76 mm | DUCTILE IRON/ |
| | 0303-0132 | | STANDARD, FLOW DIRECTION LEFT TO RIGHT | STEEL, HRD. |
| | 0303-0134 | | STANDARD, FLOW DIRECTION RIGHT TO LEFT | |
| | 0303-0022 | | OVERSIZED, FLOW DIRECTION LEFT TO RIGHT | |
| | 0303-0023 | | OVERSIZED, FLOW DIRECTION RIGHT TO LEFT | |
| 13 | | 4 | VANE, 33.6 x 13 x 5 mm | CARBON |
| | 0405-0031 | | STANDARD | |
| | 0405-0050 | | OVERSIZED | |
| | 0405-0179 | | BI-DIRECTIONAL | |
| 14 | 0404-0136 | 2 | ROD, VANE, $\varnothing 3 \times 21$ mm | AISI 316, HRD. |
| 16 | 0705-0612 | 4 | PIN, DOWEL, D=6m6, L=12 mm, DIN 6325 | STEEL, HRD. |
| 17 | 1731-0306 | 1 | SCREW, HEX. SOCKET SET, M3 x 6 mm, DIN 916, ONLY FOR FIXED MAGNET ASSY | AISI 316 |
| 19 | 0436-0112 | 2 | PIN, ECCENTRIC, $\varnothing 8 \times 5.3 \times 15$ mm | AISI 316 |

| SPARE PARTS METER WITH STANDARD VANES | VAF No. | DRAWING No. | ITEM No. | | | | |
|---------------------------------------|-----------|-------------|----------|----|----|----|----|
| | | | 5 | 8 | 11 | 13 | 14 |
| 2 YEARS WITH VITON O-RINGS | 0390-0813 | 0801-1294-4 | 1x | 2x | -- | 2x | 1x |
| 2 YEARS WITH V/PFA O-RINGS | 0390-0814 | 0801-1294-4 | 1x | 2x | -- | 2x | 1x |
| 2 YEARS WITH KALREZ O-RINGS | 0390-0905 | 0801-1294-4 | 1x | 2x | -- | 2x | 1x |
| 5 YEARS WITH VITON O-RINGS | 0390-0815 | ----- | 1x | 2x | 2x | 4x | 2x |

ASSEMBLY METER SEE DRAWING 0801-1344-3

| | | |
|--|--|-------------------------|
| <h1>VAF</h1> <p>INSTRUMENTS</p> <p>PARTS LIST METER B5015DXX DN15 PN40 WITH FLANGES</p> | | DATE : 21-03-2011 |
| | | DRAWN : PPS |
| | | CHECKED : B/ |
| | | MATERIAL : DUCTILE IRON |
| | | SEMI MAT. : - |
| | | 0801-2310 |
| | | PART OF |
| | | C REV |

| | | | | | |
|-----|----------------|----------|-----|--|---|
| C | LOGO GEWIJZIGD | 21-03-11 | PPS | | THIS CONFIDENTIAL DOCUMENT IS THE SOLE PROPERTY OF VAF INSTRUMENTS IT MUST NOT BE REPRODUCED IN ANY MATERIAL FORM, OR ITS CONTENTS DIVULGED TO A THIRD PARTY WITHOUT PRIOR WRITTEN AUTHORIZATION. |
| No. | DESCRIPTION | DATE | PAR | | |

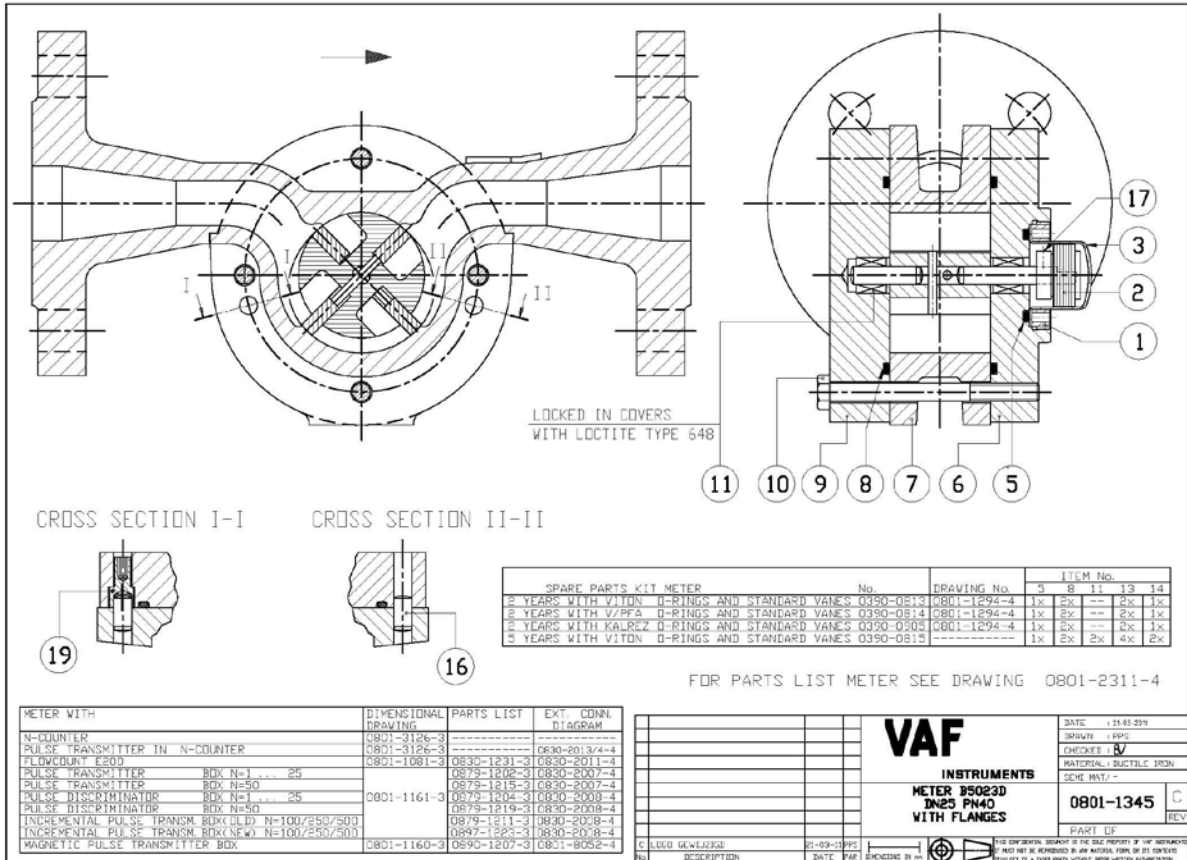

| ITEM No. | PART NUMBER | QTY | PART NAME | MATERIAL | | | | | | | |
|--|----------------|----------|--|---|-------------------------|---|-----|----|----|--|--|
| 1 | 0417-0005 | 1 | NUT, MAGNET CAP M36x1.5, ID 22.8x6mm | AISI 316 | | | | | | | |
| 2 | | 1 | ASSY, MAGNET | | | | | | | | |
| | 0313-0004 | | STANDARD, $\varnothing 20.9 \times 15$ mm | FERROXDURE/ | | | | | | | |
| | 0313-0019 | | FIXED, INCL. ITEM 17, $\varnothing 20.9 \times 15$ mm | AISI 316 | | | | | | | |
| | 0313-0031 | | CLOSED, $\varnothing 20.9 \times 14$ mm | AISI 316 | | | | | | | |
| | 0313-0045 | | CLOSED + FIXED, INCL. ITEM 17, $\varnothing 20.9 \times 14$ mm | AISI 316 | | | | | | | |
| 3 | 0409-0026 | 1 | CAP, MAGNET, $\varnothing 22.6/\varnothing 34 \times 21$ mm | AISI 316 | | | | | | | |
| 5 | | 1 | O-RING, ID 25.07 x $\varnothing 2.62$ mm | | | | | | | | |
| | 0630-3120 | | STANDARD | VITON | | | | | | | |
| | 0630-4120 | | OPTIONAL | VITON/PFA | | | | | | | |
| | 0630-9120 | | OPTIONAL | KALREZ | | | | | | | |
| 6 | 0302-0228 | 1 | COVER, FRONT, INCLUDING 1xITEM 11, $\varnothing 98 \times 20$ mm | DUCTILE IRON | | | | | | | |
| 7 | | 1 | HOUSING, INCLUDING ITEM No. 16 | DUCTILE IRON | | | | | | | |
| | 0401-0544 | | FLANGE, DIN PN10/16/25/40 | | | | | | | | |
| | 0401-0545 | | FLANGE, ANSI CLASS 150RF | | | | | | | | |
| | 0401-0546 | | FLANGE, ANSI CLASS 300RF | | | | | | | | |
| | 0401-0584 | | FLANGE, JIS 5K | | | | | | | | |
| | 0401-0547 | | FLANGE, JIS 10/16/20K | | | | | | | | |
| | 0401-0633 | | FLANGE, DIN PN10/16/25/40 DIN 2512 | | | | | | | | |
| 8 | | 2 | O-RING, ID 59.99 x $\varnothing 2.62$ mm | | | | | | | | |
| | 0630-3142 | | STANDARD | VITON | | | | | | | |
| | 0630-4142 | | OPTIONAL | VITON/PFA | | | | | | | |
| | 0630-9142 | | OPTIONAL | KALREZ | | | | | | | |
| 9 | 0302-0229 | 1 | COVER, BACK, INCLUDING 1xITEM 11, $\varnothing 98 \times 20$ mm | DUCTILE IRON | | | | | | | |
| 10 | 0732-0670 | 4 | BOLT, HEX, HEAD. M6 x 70 mm, DIN 931 | STEEL 8.8 | | | | | | | |
| 11 | 0604-0017 | 2 | BEARING, NEEDLE, OD 12 x ID 6 x 10 mm | STEEL | | | | | | | |
| 12 | | 1 | ROTOR, ASSY, OD 42/6 x 76 mm | DUCTILE IRON/STEEL, HRD. | | | | | | | |
| | 0303-0132 | | STANDARD, FLOW DIRECTION LEFT TO RIGHT | | | | | | | | |
| | 0303-0134 | | STANDARD, FLOW DIRECTION RIGHT TO LEFT | | | | | | | | |
| | 0303-0022 | | OVERSIZED, FLOW DIRECTION LEFT TO RIGHT | | | | | | | | |
| | 0303-0023 | | OVERSIZED, FLOW DIRECTION RIGHT TO LEFT | | | | | | | | |
| 13 | | 4 | VANE, 33.6 x 13 x 5 mm | CARBON | | | | | | | |
| | 0405-0031 | | STANDARD | | | | | | | | |
| | 0405-0050 | | OVERSIZED | | | | | | | | |
| | 0405-0179 | | BI-DIRECTIONAL | | | | | | | | |
| 14 | 0404-0136 | 2 | ROD, VANE, $\varnothing 3 \times 21$ mm | AISI 316, HRD. | | | | | | | |
| 16 | 0705-0612 | 4 | PIN, DOWEL, D=6m6, L=12 mm, DIN 6325 | STEEL, HRD. | | | | | | | |
| 17 | 1731-0306 | 1 | SCREW, HEX. SOCKET SET, M3 x 6 mm, DIN 916, ONLY FOR FIXED MAGNET ASSY | AISI 316 | | | | | | | |
| 19 | 0436-0112 | 2 | PIN, ECCENTRIC, $\varnothing 8 \times 5.3 \times 15$ mm | AISI 316 | | | | | | | |
| SPARE PARTS METER WITH STANDARD VANES | | | | | | | | | | | |
| | | | VAF No. | DRAWING No. | ITEM No. | | | | | | |
| | | | | | 5 | 8 | 11 | 13 | 14 | | |
| 2 YEARS WITH VITON O-RINGS | | | 0390-0813 | 0801-1294-4 | 1x | 2x | -- | 2x | 1x | | |
| 2 YEARS WITH V/PFA O-RINGS | | | 0390-0814 | 0801-1294-4 | 1x | 2x | -- | 2x | 1x | | |
| 2 YEARS WITH KALREZ O-RINGS | | | 0390-0905 | 0801-1294-4 | 1x | 2x | -- | 2x | 1x | | |
| 5 YEARS WITH VITON O-RINGS | | | 0390-0815 | ----- | 1x | 2x | 2x | 4x | 2x | | |
| ASSEMBLY METER SEE DRAWING 0801-1345-3 | | | | | | | | | | | |
| <h1 style="margin: 0;">VAF</h1> <p style="margin: 0;">INSTRUMENTS</p> <p style="margin: 0;">PARTS LIST METER B5023DXX DN25 PN40 WITH FLANGES</p> | | | | | DATE : 21-03-2011 | | | | | | |
| | | | | | DRAWN : PPS | | | | | | |
| | | | | | CHECKED : B/ | | | | | | |
| | | | | | MATERIAL : DUCTILE IRON | | | | | | |
| | | | | | SEMI MAT. : - | | | | | | |
| | | | | | 0801-2311 | | C | | | | |
| | | | | | PART OF | | REV | | | | |
| C | LOGO GEWIJZIGD | 21-03-11 | PPS |  | | THIS CONFIDENTIAL DOCUMENT IS THE SOLE PROPERTY OF VAF INSTRUMENTS. IT MUST NOT BE REPRODUCED IN ANY MATERIAL FORM, OR ITS CONTENTS DISCLOSED TO A THIRD PARTY WITHOUT PRIOR WRITTEN AUTHORIZATION. | | | | | |
| No. | DESCRIPTION | DATE | PAR | DIMENSIONS IN mm | | | | | | | |

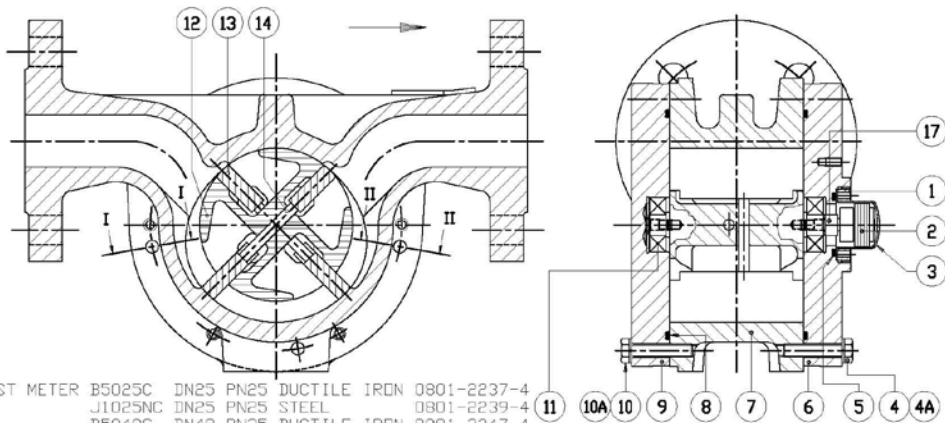

PARTS LIST METER B5025C DN25 PN25 DUCTILE IRON 0801-2237-4
 J1025NC DN25 PN25 STEEL 0801-2239-4
 B5040C DN40 PN25 DUCTILE IRON 0801-2247-4
 J1040NC DN40 PN25 STEEL 0801-2249-4

CROSS SECTION I-I CROSS SECTION II-II

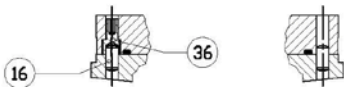

| SPARE PARTS KIT METER | No. | DRAWING No. | ITEM No. | | | | |
|---|-----------|-------------|----------|----|----|----|----|
| | | | 5 | 8 | 11 | 13 | 14 |
| 2 YEARS WITH VITON O-RINGS & STANDARD VANES | 0390-1121 | 0801-1335-4 | 1x | 2x | -- | 2x | 1x |
| 2 YEARS WITH V/PFA O-RINGS & STANDARD VANES | 0390-1131 | 0801-1351-4 | 1x | 2x | -- | 2x | 1x |
| 5 YEARS WITH VITON O-RINGS & STANDARD VANES + | | | | | | | |
| STANDARD BEARINGS | 0390-1122 | ----- | 1x | 2x | 2x | 4x | 2x |
| HIGH TEMP BEARINGS | 0390-1250 | ----- | 1x | 2x | 2x | 4x | 2x |
| ONLY VITON O-RINGS | 0390-1206 | 0801-1361-4 | 1x | 2x | -- | -- | -- |

| DIMENSIONAL DRAWING METER WITH | B5025C J1025NC | B5040C J1040C |
|--|-------------------|------------------|
| N-COUNTER | 0801-3117-3 | 0801-3118-3 |
| ELECTRONIC COUNTER TYPE FLOWCOUNT E200 | 0801-3130-3 | 0801-3131-3 |
| INDUCTIVE/INCREMENTAL PULSE TRANSMITTER BOX | 0801-3133-3 | 0801-3134-3 |

| | | | |
|---|-------------|---|---|
| | | DATE 1-25-83 | |
| | | DRAWN 1 RPS | |
| | | CHECKED <input checked="" type="checkbox"/> | |
| | | MATERIAL - | |
| INSTRUMENTS ASSEMBLY DRAWING VANEMETER B5025C / B5040C J1025NC / J1040NC | | SCALE MAT: - | |
| | | 0801-1334 | D |
| PART OF | | | |
| 3. LEAD KNOWLEDGE | 21-029-0000 | THIS DRAWING REMAINS THE SOLE PROPERTY OF VAF INSTRUMENTS | |
| NO. DESCRIPTION | DATE | BY | IF NOT SET BY APPROVED BY AND APPROVAL FORM OR BY CONSENT |

| ITEM No. | PART NUMBER | QTY | PART NAME | MATERIAL |
|----------|-------------|-----|---|---------------------|
| 1 | 0417-0005 | 1 | NUT, RING, M36x1.5 x ID 22.8 x 6 mm | AISI 316 |
| 2 | | 1 | ASSY, MAGNET | |
| | 0313-0004 | | STANDARD, OD 20.9 x 15 mm | AISI 316/FERROXDURE |
| | 0313-0031 | | CLOSED, OD 20.9 x 10 mm | AISI 316 |
| 3 | 0409-0026 | 1 | CAP, MAGNET, OD 22.6/34 x 21 mm | AISI 316 |
| 4 | 0733-0630 | 6 | SCREW, HEX. HEAD, M6 x 30 mm, DIN 933 | STEEL 8.8 |
| 4A | 0718-0600 | 6 | SPRING WASHER M6, DIN 127 | SPRING STEEL |
| 5 | | 1 | O-RING, ID 25.07 x Ø2.62 mm | |
| | 0630-3120 | | | VITON |
| | 0630-4120 | | | VITON/PFA |
| | 0630-9120 | | | KALREZ |
| 6 | 0402-0566 | 1 | COVER, FRONT, Ø135 x 22.5 mm | DUCTILE IRON |
| 7 | | 1 | HOUSING, INCLUDING ITEM No. 16 | DUCTILE IRON |
| | 0401-0559 | | FLANGE, DIN PN6 | |
| | 0401-0057 | | FLANGE, DIN PN10/16/25/40 | |
| | 0401-0390 | | FLANGE, ANSI CLASS 150RF | |
| | 0401-0391 | | FLANGE, ANSI CLASS 300RF | |
| | 0401-0432 | | FLANGE, JIS 5K | |
| | 0401-0392 | | FLANGE, JIS 10/16/20K | |
| 8 | | 2 | O-RING, | |
| | 0630-3155 | | ID 101.27 x Ø2.62 mm | VITON |
| | 0630-4902 | | ID 104.30 x Ø2.62 mm | VITON/PFA |
| | 0630-9155 | | ID 101.27 x Ø2.62 mm | KALREZ |
| 9 | 0402-0567 | 1 | COVER, BACK, Ø135 x 18 mm | DUCTILE IRON |
| 10 | 0733-0630 | 6 | SCREW, HEX. HEAD, M6 x 30 mm, DIN 933 | STEEL 8.8 |
| 10A | 0718-0600 | 6 | SPRING WASHER M6, DIN 127 | SPRING STEEL |
| 11 | | 2 | BEARING, BALL, OD 26 x ID 10 x 8 mm | |
| | 2601-6000 | | STANDARD WITH 2 GUARD PLATES | STEEL |
| | 0601-6000 | | OVERSIZED | STEEL |
| | 1601-6000 | | STAINLESS STEEL | STAINLESS STEEL |
| | 4601-6000 | | SYNTHETIC CAGE | STEEL |
| | 0601-7008 | | HIGH TEMP | STEEL |
| 12 | | 1 | ROTOR, OD 73/10 x 64/84 mm | DUCTILE IRON |
| | 0403-0138 | | STANDARD | |
| | 0403-0001 | | OVERSIZED | |
| 13 | | 4 | VANE, 64 x 24 x 8 mm | CARBON |
| | 0405-0029 | | STANDARD | |
| | 0405-0041 | | OVERSIZED | |
| 14 | 0404-0126 | 2 | ROD, VANE Ø5 x 35 mm | AISI 316, HRD. |
| 16 | 0705-0612 | 4 | PIN, DOWEL, Ø6m6 x 12 mm, DIN 6325 | STEEL, HRD. |
| 17 | | 1 | SHAFT, MAGNET, OD 10 / M5x0.5 L=33.5 mm | STEEL |
| | 0404-0412 | | FLOW DIRECTION LEFT TO RIGHT | |
| | 0404-0413 | | FLOW DIRECTION RIGHT TO LEFT | |
| 36 | 0436-0112 | 2 | PIN, ECCENTRIC OD 8/5.3 x 17 mm | AISI 316 |

ASSEMBLY DRAWING 0801-1334-3

| | | | | |
|---|-------------|------|--|-------------------------|
|  <p>VAF INSTRUMENTS PARTS LIST METER B5025C DN25 PN25</p> | | | | DATE : 21-03-2011 |
| | | | | DRAWN : PPS |
| | | | | CHECKED : <u>BV</u> |
| | | | | MATERIAL : DUCTILE IRON |
| | | | | SEMI MAT. : - |
| | | | 0801-2237 | C |
| | | | PART OF | REV |
| C LOGO GEWIJZIGD | 21-03-11 | PPS | THIS CONFIDENTIAL DOCUMENT IS THE SOLE PROPERTY OF VAF INSTRUMENTS IT MUST NOT BE REPRODUCED IN ANY MATERIAL FORM, OR ITS CONTENTS DISCLOSED TO A THIRD PARTY WITHOUT PRIOR WRITTEN AUTHORIZATION. | |
| No. | DESCRIPTION | DATE | PAR | DIMENSIONS IN mm |

| ITEM No. | PART NUMBER | QTY | PART NAME | MATERIAL |
|----------|-------------|-----|---|---------------------|
| 1 | 0417-0005 | 1 | NUT, RING, M36x1.5 x ID 22.8 x 6 mm | AISI 316 |
| 2 | | 1 | ASSY, MAGNET | |
| | 0313-0004 | | STANDARD, OD 20.9 x 15 mm | AISI 316/FERROXDURE |
| | 0313-0031 | | CLOSED, OD 20.9 x 10 mm | AISI 316 |
| 3 | 0409-0026 | 1 | CAP, MAGNET, OD 22.6/34 x 21 mm | AISI 316 |
| 4 | 0733-0630 | 6 | SCREW, HEX. HEAD, M6 x 30 mm, DIN 933 | STEEL 8.8 |
| 4A | 0718-0600 | 6 | SPRING WASHER M6, DIN 127 | SPRING STEEL |
| 5 | | 1 | O-RING, ID 25.07 x Ø2.62 mm | |
| | 0630-3120 | | | VITON |
| | 0630-4120 | | | VITON/PFA |
| | 0630-9120 | | | KALREZ |
| 6 | 0402-0566 | 1 | COVER, FRONT, Ø135 x 22.5 mm | DUCTILE IRON |
| 7 | | 1 | HOUSING, INCLUDING ITEM No. 16 | DUCTILE IRON |
| | 0401-0352 | | FLANGE, DIN PN10/16/25/40 | |
| | 0401-0353 | | FLANGE, ANSI CLASS 150RF | |
| | 0401-0354 | | FLANGE, ANSI CLASS 300RF | |
| | 0401-0431 | | FLANGE, JIS 5K | |
| | 0401-0396 | | FLANGE, JIS 10/16/20K | |
| 8 | | 2 | O-RING, | |
| | 0630-3155 | | ID 101.27 x Ø2.62 mm | VITON |
| | 0630-4902 | | ID 104.30 x Ø2.62 mm | VITON/PFA |
| | 0630-9155 | | ID 101.27 x Ø2.62 mm | KALREZ |
| 9 | 0402-0567 | 1 | COVER, BACK, Ø135 x 18 mm | DUCTILE IRON |
| 10 | 0733-0630 | 6 | SCREW, HEX. HEAD, M6 x 30 mm, DIN 933 | STEEL 8.8 |
| 10A | 0718-0600 | 6 | SPRING WASHER M6, DIN 127 | SPRING STEEL |
| 11 | | 2 | BEARING, BALL, OD 26 x ID 10 x 8 mm | |
| | 2601-6000 | | STANDARD WITH 2 GUARD PLATES | STEEL |
| | 0601-6000 | | OVERSIZED | STEEL |
| | 1601-6000 | | STAINLESS STEEL | STAINLESS STEEL |
| | 4601-6000 | | SYNTHETIC CAGE | STEEL |
| | 0601-7008 | | HIGH TEMP | STEEL |
| 12 | | 1 | ROTOR, OD 73/10 x 64/84 mm | DUCTILE IRON |
| | 0403-0138 | | STANDARD | |
| | 0403-0001 | | OVERSIZED | |
| 13 | | 4 | VANE, 64 x 24 x 8 mm | CARBON |
| | 0405-0029 | | STANDARD | |
| | 0405-0041 | | OVERSIZED | |
| 14 | 0404-0126 | 2 | ROD, VANE Ø5 x 35 mm | AISI 316, HRD. |
| 16 | 0705-0612 | 4 | PIN, DOWEL, Ø6m6 x 12 mm, DIN 6325 | STEEL, HRD. |
| 17 | | 1 | SHAFT, MAGNET, OD 10 / M5x0.5 L=33.5 mm | STEEL |
| | 0404-0412 | | FLOW DIRECTION LEFT TO RIGHT | |
| | 0404-0413 | | FLOW DIRECTION RIGHT TO LEFT | |
| 36 | 0436-0112 | 2 | PIN, ECCENTRIC OD 8/5.3 x 15 mm | AISI 316 |

ASSEMBLY DRAWING 0801-1334-3

| | | | | | | |
|-----|----------------|----------|---|--|--|--|
| | | | <h1>VAF</h1> <p>INSTRUMENTS</p> <p>PARTS LIST METER B5040C DN40 PN25</p> | | DATE : 21-03-2011 | |
| | | | | | DRAWN : PPS | |
| | | | | | CHECKED : B/ | |
| | | | | | MATERIAL : DUCTILE IRON | |
| | | | | | SEMI MAT. : - | |
| | | | | | 0801-2247 | |
| | | | | | D | |
| | | | | | REV | |
| | | | | | PART OF | |
| D | LOGO GEWIJZIGD | 21-03-11 | PPS | | <small>THIS CONFIDENTIAL DOCUMENT IS THE SOLE PROPERTY OF VAF INSTRUMENTS IT MUST NOT BE REPRODUCED IN ANY MATERIAL FORM, OR ITS CONTENTS UNVALUED TO A THIRD PARTY WITHOUT PRIOR WRITTEN AUTHORIZATION.</small> | |
| No. | DESCRIPTION | DATE | PAR | | | |

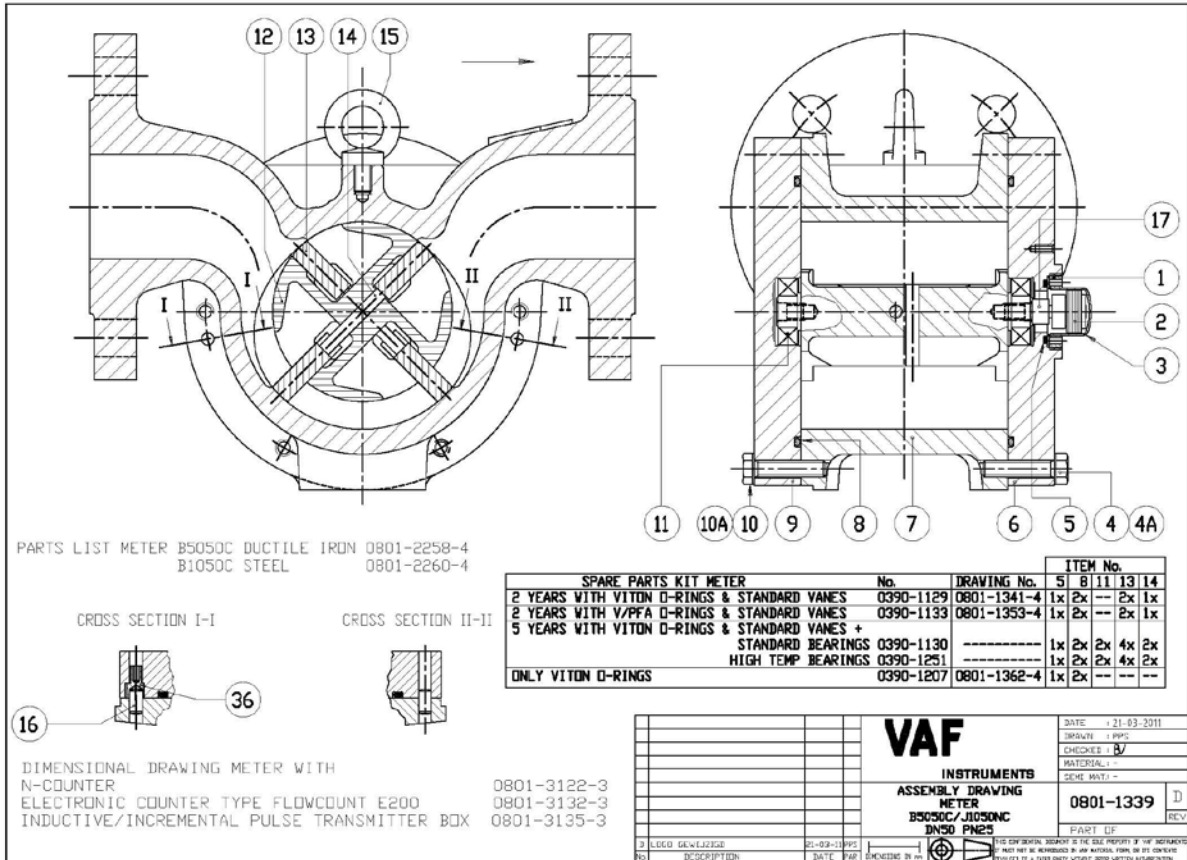

| ITEM No. | PART NUMBER | QTY | PART NAME | MATERIAL |
|----------|-------------|-----|--|---------------------|
| 1 | 0417-0005 | 1 | NUT, RING, M36x1.5 x ID 22.8 x 6 mm | AISI 316 |
| 2 | | 1 | ASSY, MAGNET | |
| | 0313-0004 | | STANDARD, OD 20.9 x 15 mm | AISI 316/FERROXDURE |
| | 0313-0031 | | CLOSED, OD 20.9 x 10 mm | AISI 316 |
| 3 | 0409-0026 | 1 | CAP, MAGNET, OD 22.6/34 x 21 mm | AISI 316 |
| 4 | 0733-0835 | 6 | SCREW, HEX. HEAD, M8 x 35 mm, DIN 933 | STEEL 8.8 |
| 4A | 0718-0800 | 6 | SPRING WASHER M8, DIN 127 | SPRING STEEL |
| 5 | | 1 | O-RING, ID 25.07 x Ø2.62 mm | |
| | 0630-3120 | | | VITON |
| | 0630-4120 | | | VITON/PFA |
| | 0630-9120 | | | KALREZ |
| 6 | 0402-0573 | 1 | COVER, FRONT, Ø166 x 26 mm | DUCTILE IRON |
| 7 | | 1 | HOUSING, INCLUDING ITEM No. 16 | DUCTILE IRON |
| | 0401-0393 | | FLANGE, DIN PN10/16/25/40 | |
| | 0401-0394 | | FLANGE, ANSI CLASS 150RF | |
| | 0401-0395 | | FLANGE, ANSI CLASS 300RF | |
| | 0401-0482 | | FLANGE, JIS 5K | |
| | 0401-0481 | | FLANGE, JIS 10K | |
| | 0401-0607 | | FLANGE, JIS 16/20K | |
| 8 | | 2 | O-RING, | |
| | 0630-3248 | | ID 120.24 x Ø3.53 mm | VITON |
| | 0630-4911 | | ID 121.80 x Ø3.53 mm | VITON/PFA |
| | 0630-9248 | | ID 120.24 x Ø3.53 mm | KALREZ |
| 9 | 0402-0574 | 1 | COVER, BACK, Ø166 x 22 mm | DUCTILE IRON |
| 10 | 0733-0835 | 6 | SCREW, HEX. HEAD, M8 x 35 mm, DIN 933 | STEEL 8.8 |
| 10A | 0718-0800 | 6 | SPRING WASHER M8, DIN 127 | SPRING STEEL |
| 11 | | 2 | BEARING, BALL, OD 32 x ID 15 x 9 mm | |
| | 2601-6002 | | STANDARD WITH 2 GUARD PLATES | STEEL |
| | 0601-6002 | | OVERSIZED | STEEL |
| | 1601-6002 | | STAINLESS STEEL | STAINLESS STEEL |
| | 4601-6002 | | SYNTHETIC CAGE | STEEL |
| | 0601-7009 | | HIGH TEMP | STEEL |
| 12 | | 1 | ROTOR, OD 86/15 x 99/122 mm | DUCTILE IRON |
| | 0403-0139 | | STANDARD | |
| | 0403-0002 | | OVERSIZED | |
| 13 | | 4 | VANE, 99 x 30 x 10 mm | CARBON |
| | 0405-0030 | | STANDARD | |
| | 0405-0042 | | OVERSIZED | |
| 14 | 0404-0127 | 2 | ROD, VANE Ø6 x 39 mm | AISI 316, HRD. |
| 15 | 0799-0079 | 1 | EYE-BOLT, M8, DIN 580 | STEEL |
| 16 | 0705-0612 | 4 | PIN, DOWEL, Ø6m6 x 12 mm, DIN 6325 | STEEL, HRD. |
| 17 | | 1 | SHAFT, MAGNET, OD 12/M8x0.75 L=37.5 mm | STEEL |
| | 0404-0424 | | FLOW DIRECTION LEFT TO RIGHT | |
| | 0404-0425 | | FLOW DIRECTION RIGHT TO LEFT | |
| 36 | 0436-0112 | 2 | PIN, ECCENTRIC OD 8/5.3 x 15 mm | AISI 316 |

ASSEMBLY DRAWING 0801-1339-3

| | | | | |
|------------------|----------|--|--|---|
| | | VAF | | DATE : 21-03-2011 |
| | | | | DRAWN : PPS |
| | | INSTRUMENTS | | CHECKED : B/ |
| | | | | MATERIAL : DUCTILE IRON |
| | | PARTS LIST METER B5050C DN50 PN25 | | SEMI MAT. : - |
| | | | | 0801-2258 |
| | | | | PART OF |
| C LOGO GEWIJZIGD | 21-03-11 | PPS | | THIS CONFIDENTIAL DOCUMENT IS THE SOLE PROPERTY OF VAF INSTRUMENTS IT MUST NOT BE REPRODUCED IN ANY MATERIAL FORM, OR ITS CONTENTS DIVULGED TO A THIRD PARTY WITHOUT PRIOR WRITTEN AUTHORIZATION. |
| No. DESCRIPTION | DATE | PAR | | |

17.2 DIMENSIONAL DRAWINGS

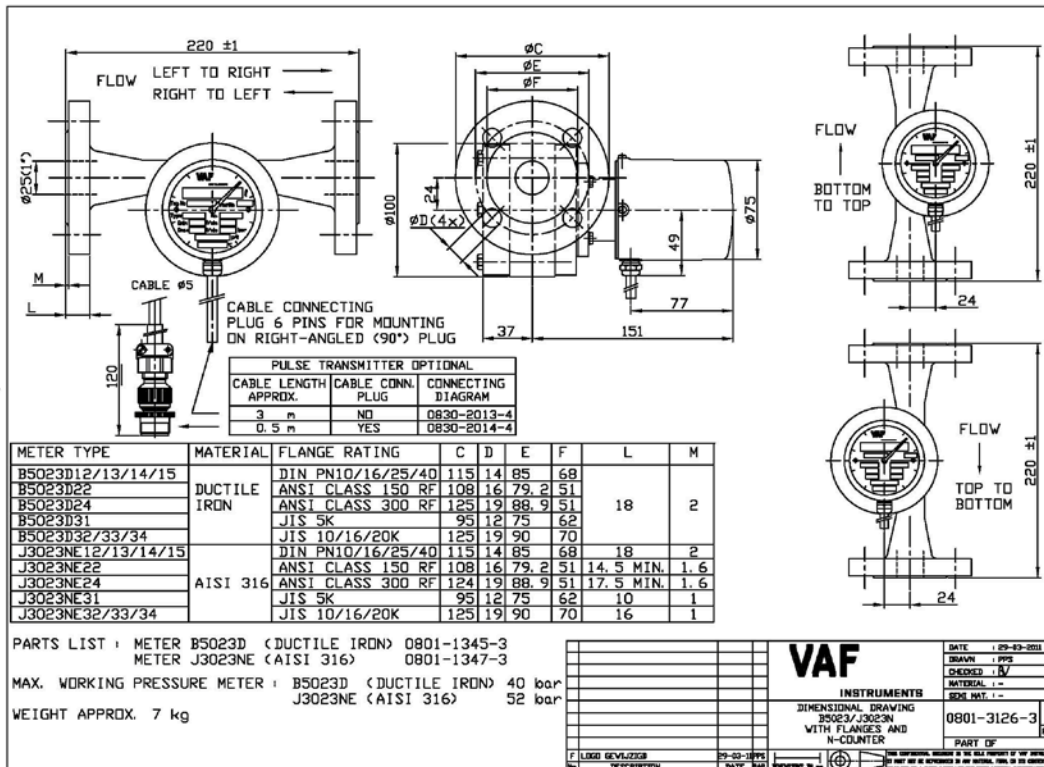
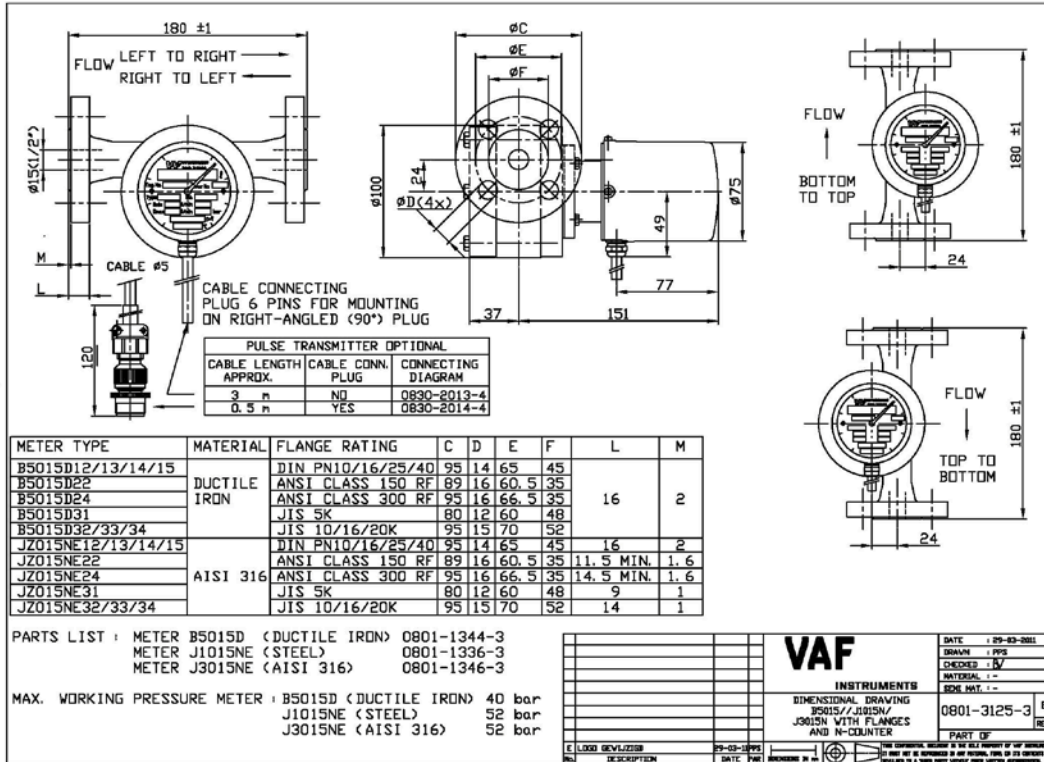

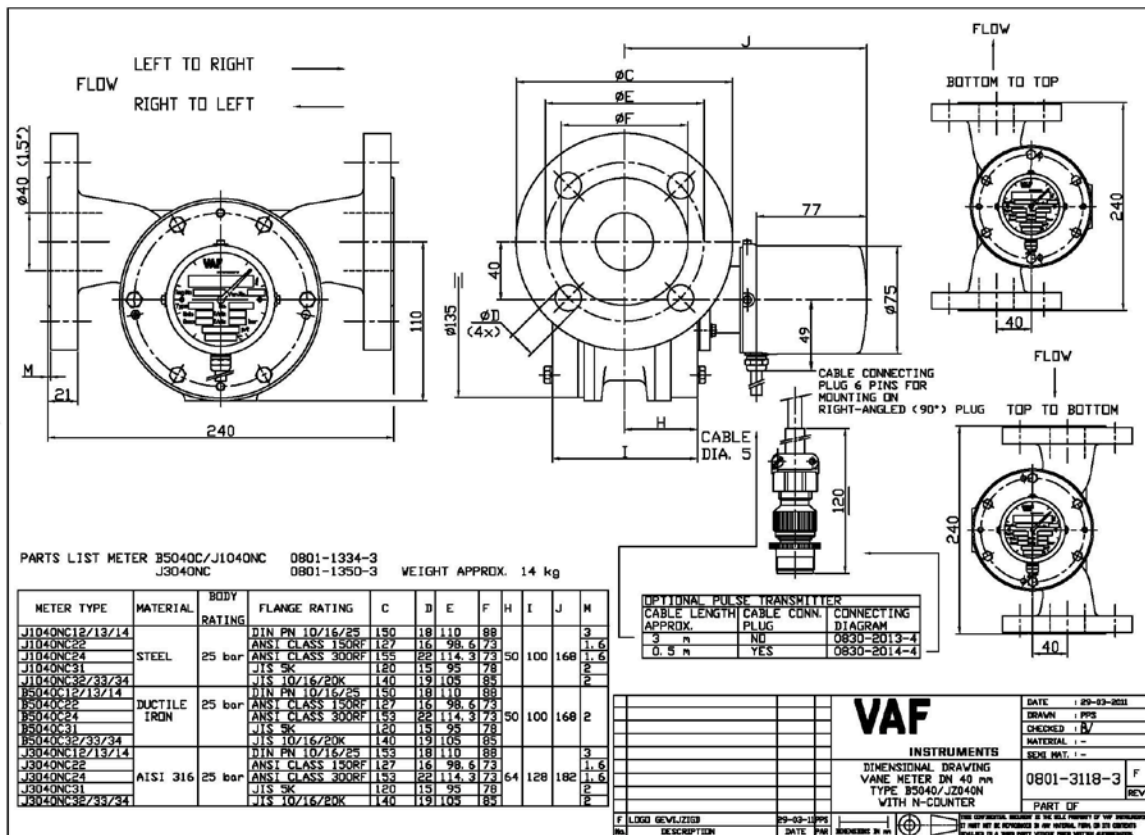
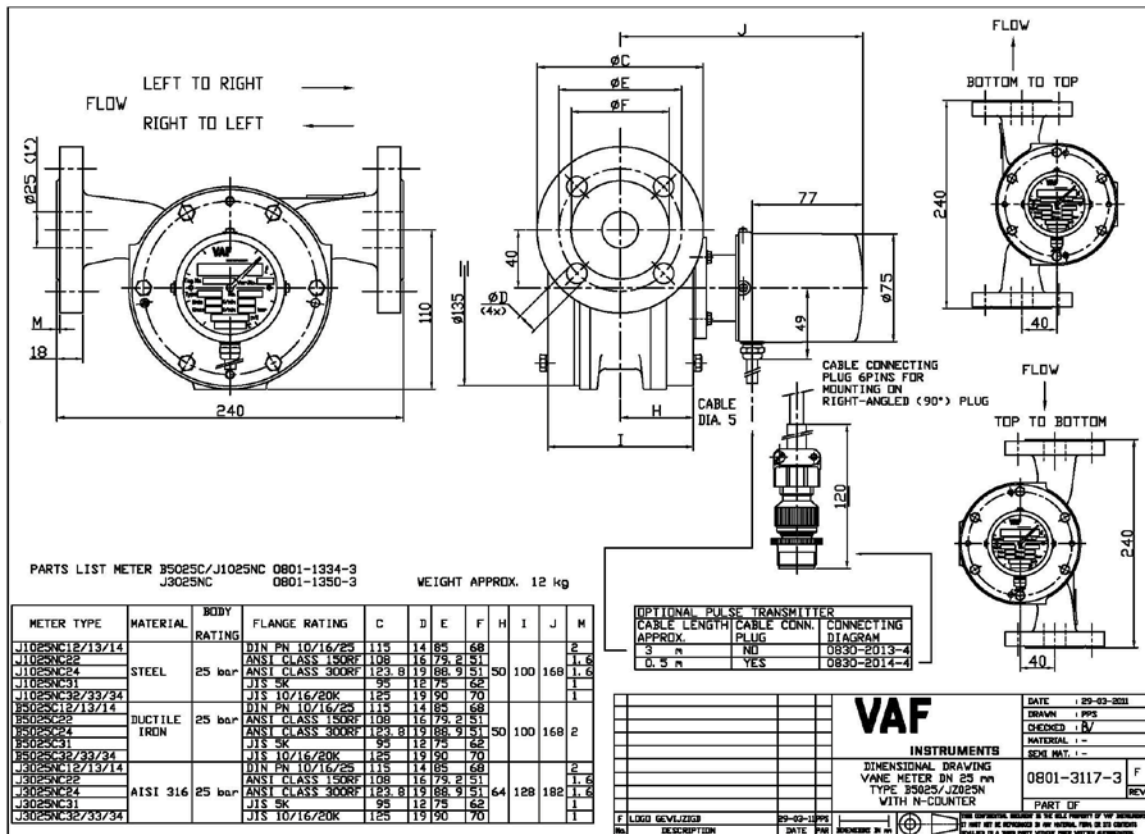

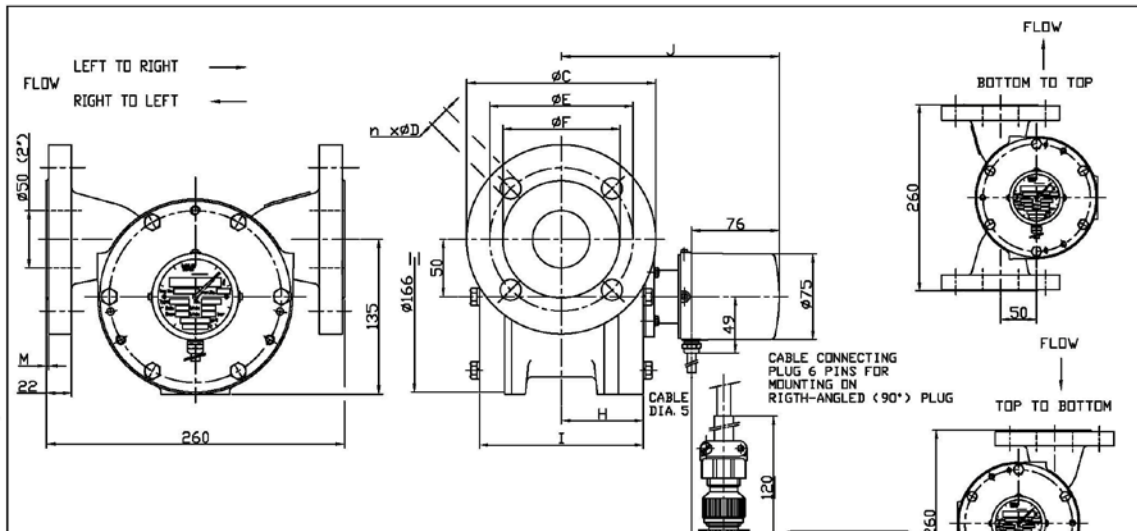

PARTS LIST METER B5050C/J1050NC 0801-1339-3
 J3050NC 0801-1352-3 WEIGHT APPROX. 24 kg

| METER TYPE | MATERIAL | BODY RATING | FLANGE RATING | C | W | E | F | H | J | M | |
|-----------------|------------------|-------------|------------------|-----|------|-----|-----|-----|-----|-----|-----|
| J1050NC12/13/14 | STEEL | 25 bar | DIN PN 10/16/25 | 165 | 4x13 | 105 | 88 | 72 | 143 | 190 | 3 |
| J1050NC22 | | | ANSI CLASS 1500F | 136 | 4x13 | 105 | 88 | 72 | 143 | 190 | 1-5 |
| J1050NC24 | | | ANSI CLASS 3000F | 165 | 8x13 | 105 | 88 | 72 | 143 | 190 | 2 |
| J1050NC31 | | | JIS SK | 130 | 4x13 | 105 | 88 | 72 | 143 | 190 | 2 |
| J1050NC32 | DUCTILE IRON | 25 bar | JIS TK | 130 | 4x13 | 105 | 88 | 72 | 143 | 190 | 2 |
| J1050NC33/34 | | | JIS 16/20K | 150 | 8x13 | 105 | 100 | 72 | 143 | 190 | 2 |
| B5050C12/13/14 | | | DIN PN 10/16/25 | 165 | 4x13 | 105 | 88 | 72 | 143 | 190 | 3 |
| B5050C22 | | | ANSI CLASS 1500F | 136 | 4x13 | 105 | 88 | 72 | 143 | 190 | 1-5 |
| B5050C24 | ANSI CLASS 3000F | 165 | 8x13 | 105 | 88 | 72 | 143 | 190 | 2 | | |
| B5050C31 | JIS SK | 130 | 4x13 | 105 | 88 | 72 | 143 | 190 | 2 | | |
| B5050C32 | JIS TK | 130 | 4x13 | 105 | 88 | 72 | 143 | 190 | 2 | | |
| B5050C33/34 | JIS 16/20K | 150 | 8x13 | 105 | 100 | 72 | 143 | 190 | 2 | | |
| J3050NC12/13/14 | AISI 316 | 25 bar | DIN PN 10/16/25 | 165 | 4x13 | 105 | 88 | 72 | 143 | 190 | 3 |
| J3050NC22 | | | ANSI CLASS 1500F | 136 | 4x13 | 105 | 88 | 72 | 143 | 190 | 1-5 |
| J3050NC24 | | | ANSI CLASS 3000F | 165 | 8x13 | 105 | 88 | 72 | 143 | 190 | 2 |
| J3050NC31 | | | JIS SK | 130 | 4x13 | 105 | 88 | 72 | 143 | 190 | 2 |
| J3050NC32 | JIS TK | 130 | 4x13 | 105 | 88 | 72 | 143 | 190 | 2 | | |
| J3050NC33/34 | JIS 16/20K | 150 | 8x13 | 105 | 100 | 72 | 143 | 190 | 2 | | |

| OPTIONAL PULSE TRANSMITTER | | |
|----------------------------|-------------|--------------------|
| CABLE LENGTH | CABLE CONN. | CONNECTING DIAGRAM |
| APPROX. | PLUG | |
| 3 m | NI | 0830-2013-4 |
| 0.5 m | YES | 0830-2014-4 |

VAF

INSTRUMENTS

DIMENSIONAL DRAWING
 VANE METER 1050 WITH
 TYPE B5050C/J3050NC
 WITH N-COUNTER

DATE: 08-03-2011
 DRAWN: PPS
 CHECKED: N
 MATERIAL: 1-
 SPEC. NAT.: 1-
 PART OF: 0801-3122-3
 REV: F

F L000 08/12/2008 08-03-10/PPS
 DESCRIPTION DATE PPS DRAWING IN

THIS INSTRUMENT IS THE PROPERTY OF VAF INSTRUMENTS
 IT MUST NOT BE REPAIRED IN ANY MANNER, EVEN IN THE CASE
 OF DAMAGE TO A THIRD PARTY, WITHOUT VAF'S PERMISSION.

18. ABBREVIATIONS

19. SPARE PARTS

Contact VAF Instruments or local agent for spare parts for flowmeter type ProFlow.

20. WARRANTY CONDITIONS

1. Without prejudice to the restrictions stated hereinafter, the contractor guarantees both the soundness of the product delivered by him and the quality of the material used and/or delivered for it, insofar as this concerns faults in the product delivered which do not become apparent during inspection or transfer test, which the principal shall demonstrate to have arisen within 12 months from delivery in accordance with subarticle 1A exclusively or predominantly as a direct consequence of unsoundness of the construction used by the contractor or as a consequence of faulty finishing or the use of poor materials.
 - 1A. The product shall be deemed to have been delivered when it is ready for inspection (if inspection at the premises of the contractor has been agreed) and otherwise when it is ready for shipment.
2. Articles 1 and 1a shall equally apply to faults which do not become apparent during inspection or transfer test which are caused exclusively or predominantly by unsound assembly/installation by the contractor. If assembly/installation is carried out by the contractor, the guarantee period intended in article 1 shall last 12 months from the day on which assembly/installation is completed by the contractor, with the understanding that in this case the guarantee period shall end not later than 18 months after delivery in accordance with the terms of subarticle 1A.
3. Defects covered by the guarantee intended under articles 1, 1A and 2 shall be remedied by the contractor by repair or replacement of the faulty component either on or off the premises of the contractor, or by shipment of a replacement component, this remaining at the discretion of the contractor. Subarticle 3A shall equally apply if repair or replacement takes place at the site where the product has been assembled/installed. All costs accruing above the single obligation described in the first sentence, such as are not restricted to shipment costs, travelling and accommodation costs or disassembly or assembly costs insofar as they are not covered by the agreement, shall be paid by the principal.
 - 3A. If repair or replacement takes place at the site where the product has been assembled/installed, the principal shall ensure, at his own expense and risk, that:
 - a. the employees of the contractor shall be able to commence their work as soon as they have arrived at the erection site and continue to do so during normal working hours, and moreover, if the contractor deems it necessary, outside the normal working hours, with the proviso that the contractor informs the principal of this in good time;
 - b. suitable accommodation and/or all facilities required in accordance with government regulations, the agreement and common usage, shall be available for the employees of the contractor;
 - c. the access roads to the erection site shall be suitable for the transport required;
 - d. the allocated site shall be suitable for storage and assembly;
 - e. the necessary lockable storage sites for materials, tools and other goods shall be available;
 - f. the necessary and usual auxiliary workmen, auxiliary machines, auxiliary tools, materials and working materials (including process liquids, oils and greases, cleaning and other minor materials, gas, water, electricity, steam, compressed air, heating, lighting, etc.) and the measurement and testing equipment usual for in the business operations of the principal, shall be available at the correct place and at the disposal of the contractor at the correct time and without charge;

- g. all necessary safety and precautionary measures shall have been taken and adhered to, and all measures shall have been taken and adhered to necessary to observe the applicable government regulations in the context of assembly/installation;
 - h. the products shipped shall be available at the correct site at the commencement of and during assembly.
4. Defects not covered by the guarantee are those which occur partially or wholly as a result of:
 - A. non-observance of the operation and maintenance instructions or other than foreseeable normal usage;
 - B. normal wear and tear;
 - C. assembly/installation by third parties, including the principal;
 - D. the application of any government regulation regarding the nature or quality of the material used;
 - E. materials or goods used in consultation with the principal;
 - F. materials or goods provided by the principal to the contractor for processing;
 - G. materials, goods, working methods and constructions insofar as are applied at the express instruction of the principal, and materials or goods supplied by or on behalf of the principal;
 - H. components obtained from third parties by the contractor insofar as that party has given no guarantee to the contractor.
 5. If the principal fails to fulfil any obligation properly or on time ensuing from the agreement concluded between the principal and the contractor or any agreement connected to it, the contractor shall not be bound by any of these agreements to any guarantee regardless of how it is referred to. If, without previous written approval from the contractor, the principal commences disassembly, repair or other work on the product or allows it to be commenced, then every agreement with regard to guarantee shall be void.
 6. Claims regarding defects must be submitted in writing as quickly as possible and not later than 14 days after the discovery of such. All claims against the contractor regarding faults shall be void if this term is exceeded. Claims pertaining to the guarantee must be submitted within one year of the valid complaint on penalty of invalidity.
 7. If the contractor replaces components/products under the terms of his guarantee obligations, the replaced components/products shall become the property of the contractor.
 8. Unless otherwise agreed, a guarantee on repair or overhaul work carried out by the contractor or other services shall only be given on the correctness of the manner in which the commissioned work is carried out, this for a period of 6 months. This guarantee only covers the single obligation of the contractor to carry out the work concerned once again in the event of unsound work. In this case, subarticle 3A shall apply equally.
 9. No guarantee shall be given regarded the inspection conducted, advice given and similar matters.
 10. Alleged failure to comply with his guarantee commitments on the part of the contractor shall not absolve the principal from his obligations ensuing from any agreement concluded with the contractor.
 11. No guarantee shall be given on products which form a part of, or on work and services on, goods older than 8 years.

Revision 1106:

- Instruction dismantling/re-assembling added
- Dimensional drawings and parts lists added
- New photos added

Revision 1206:

Figure 18 corrected

Revision 0608:

Recommendation added in chapter 8.1.

Revision 0711:

1. House style change
2. Text altered due to new calibration fluid

Revision 0811:

Installation requirements elucidated

Revision 0113:

Chapter 17.2 Dimensional drawings added

VAF

INSTRUMENTS

Represented by

VAF Instruments B.V.

Vierlinghstraat 24, 3316 EL Dordrecht, The Netherlands
P.O. Box 40, 3300 AA Dordrecht, The Netherlands
T +31 (0) 78 618 3100, F +31 (0) 78 617 7068
sales@vaf.nl, www.vaf.nl

Specifications subject to change without notice.

Agents and distributors in more than 50 countries.

