

# RK23191 and RK23191-01 Steel (WIF) Probe

Marine Type Approved For All Vessels

Instruction Part Number 14455 Rev -



This kit includes one water-in-fuel (WIF) probe and one connector harness.

The WIF is of rugged construction, designed to be used in marine machinery spaces that must conform to International Marine Organization (IMO) standards. This WIF is American Bureau of Shipping (ABS) certified for use aboard ABS classed vessels and may be acceptable under other International Association of Classification Societies (IACS) members.

In use, when the collected water level within the Racor filter bowl/sump rises to the height of the probe tip, a Racor Water Detection Amplifier (ordered separately) will detect the change in electrical resistance (ohms) of the fluid.

When this happens, the Amplifier will alert the operator that draining of the Racor is required.

This WIF may be used with all Racor Water Detection Amplifiers and the following Racor filter models: Turbine Series, Spin-on Series, DFBO, FBO and 800 Series.



## Contact Information: Product Features:

Parker Hannifin Corporation  
**Racor Division**  
P.O. Box 3208  
3400 Finch Road  
Modesto, CA 95353

phone 800 344 3286  
209 521 7860  
fax 209 529 3278  
racor@parker.com

parker.com/racor

- ABS Marine Type Approved, Cert. #11-HS800012-PDA.
- UL Marine Listed, 168Y.
- Meets requirements of ISO19921 fire resistance test.
- 303 Stainless Steel and Ceramic construction.
- SAEJ1926 Straight thread with O-ring sealing design.
- Fluorocarbon (FKM) O-ring for durable service life.
- Detachable Packard GT-Series 2-terminal connector.
- 36" long 18AWG yellow/black wires (no polarity) (RK23191).
- 8" long 18AWG yellow/black wires (no polarity) harness with Deutsch DT04-3P connector (RH23191-01).



ENGINEERING YOUR SUCCESS.

# Technical Information

Specifications	RK23191	RK23191-01
Volts	12 or 24	12 or 24
Wire Length	36.0 in. (83.8 cm)	8.0 in. (20.3 cm)
Internal Resistor	None	None
Mating Connector	None	Deutsch DT04-3P

# Mounting Information

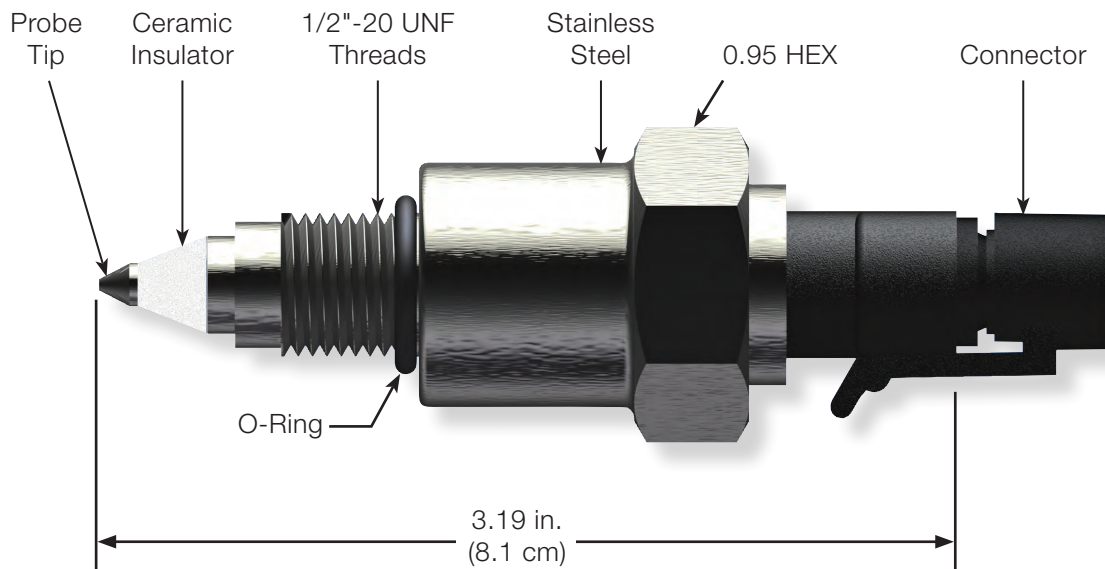

# Installation Guidelines

**Note:** When installing the WIF in a DFBO, FBO, or 800 Series model, the use of a thread adapter (73249) is required. Apply thread paste to the male threads and install the adapter into the housing port. Tighten adequately and then continue.

1. The WIF is installed in Turbine Series or Spin-on Series contaminant collection bowls by removing the existing probe port plug. This plug will have 1/2"-20 straight threads and an o-ring will be present.
2. Clean the sealing gland of the port with a clean cloth to remove any debris.
3. Apply silicone grease or clean diesel fuel to the WIF O-ring.
4. Install the WIF into the port and tighten to 90 inch pounds (10 newton/m) max.
5. Refer to the instructions provided with the Racor Water Detection Amplifier to complete the wiring procedure.

**Note:** The WIF is passive so it has no polarity (no hot or ground) but you may use the black wire as the 'ground' and the 'yellow' wire for the signal wire, just to make it easier to hook the WIF up to your Amplifier wiring diagram. Use cable tie-wraps to secure the wires away from moving or hot surfaces.

6. Ensure the final connection of the harness to the WIF connector housing is made prior to testing the system.

## Water Detection Modules & Kits

Part Number	Description	Voltage
RK 12870	Under-dash Water Detection Module Light and sound when water is detected. Water must be drained to reset light and stop horn. Plastic enclosure measures: 1.38" square x 1.25" deep.	12 vdc
RK 12971	Same as above	24 vdc
RK 20725	Under-dash Mount Water Detection Module Light only. Green 'ON' lamp illuminates with power on. Red 'DRAIN' lamp illuminates when water is detected. Initial power-up self diagnosis feature and circuit protection included. Plastic enclosure measures: 2.75" x 1" x 1.5".	12 vdc
RK 20725-24	Same as above	24 vdc
RK 20726	2" Gauge Type Water Detection Module Light and audio. Red 'DRAIN' lamp illuminates and horn sounds when water is detected. Initial power-up self diagnosis feature and circuit protection included. Plastic case, satin black dial with white lettering.	12 or 24 vdc
RK 11-1570	2" Gauge Type Water Detector & Filter Restriction Module Includes pre-set vacuum switch (7in.Hg.), connector, and outlet adapter fitting. Red 'DRAIN' or 'CHANGE FILTER' lamp illuminate and horn sounds when water is detected.	12 or 24 vdc
RK 14329	Remote Detection Unit Sends 12 V DC hot (+) signal when water is detected or an input ground signal from a vacuum switch (not included) is received. Must be used with a relay to power a horn or indicator lamp (if draw is over 1 amp). Plastic enclosure measures: 3" x 2.5" x .75"	12 vdc
RK 14321	Same as above	24 vdc
14332	Under-dash mount Same as RK14329 but sends a ground (-) signal. Enclosure size is same as RK 20725, above.	12 vdc



# Limited Warranties Statement

All products manufactured or distributed by Racor are subject to the following, and only the following, LIMITED EXPRESS WARRANTIES, and no others: For a period of one (1) year from and after the date of purchase of a new Racor product, Racor warrants and guarantees only to the original purchaser-user that such a product shall be free from defects of materials and workmanship in the manufacturing process. The warranty period for pumps and motors is specifically limited to ninety (90) days from date of purchase. A product claimed to be defective must be returned to the place of purchase. Racor, at its sole option, shall replace the defective product with a comparable new product or repair the defective product. This express warranty shall be inapplicable to any product not properly installed and properly used by the purchaser-user or to any product damaged or impaired by external forces.

THIS IS THE EXTENT OF WARRANTIES AVAILABLE ON THIS PRODUCT. RACOR SHALL HAVE NO LIABILITY WHATSOEVER FOR CONSEQUENTIAL DAMAGES FLOWING FROM THE USE OF ANY DEFECTIVE PRODUCT

OR BY REASON OF THE FAILURE OF ANY PRODUCT. RACOR SPECIFICALLY DISAVOWS ALL OTHER WARRANTIES, EXPRESS OR IMPLIED INCLUDING, WITHOUT LIMITATION, ALL WARRANTIES OF FITNESS FOR A PARTICULAR PURPOSE (EXCEPT FOR THOSE WHICH APPLY TO PRODUCT OR PART THEREOF THAT IS USED OR BOUGHT FOR USE PRIMARILY FOR PERSONAL, FAMILY, OR HOUSEHOLD PURPOSES), WARRANTIES OF DESCRIPTION, WARRANTIES OF MERCHANTABILITY, TRADE USAGE OR WARRANTIES OR TRADE USAGE.

## Warning

Failure or improper selection or improper use of the products and/or systems described herein or related items can cause death, personal injury and property damage. This document and other information from Parker Hannifin Corporation, its subsidiaries and authorized distributors provide product and/or system options for further investigation by users having technical expertise. It is important that you analyze all aspects of your

application and review the information concerning the product or system in the current product catalog. Due to the variety of operating conditions and applications for these products or systems, the user, through its own analysis and testing, is solely responsible for making the final selection of the products and systems and assuring that all performance, safety and warning requirements of the applications are met. The products described herein, including with limitation, product features, specifications, designs, availability and pricing, are subject to change by Parker Hannifin Corporation and its subsidiaries at any time without notice.

The following statement is required pursuant to proposition 65, applicable in the State of California: 'This product may contain a chemical known to the State of California to cause cancer or reproductive toxicity'.