



ENGINEERING **YOUR** SUCCESS.

Aqua Matic Compact 450-1800

Owner's Manual

SYSTEM MODELS

SRC Aqua Matic 450-1

SRC Aqua Matic 900-2

SRC Aqua Matic 700-1

SRC Aqua Matic 1400-2

SRC Aqua Matic 900-1

SRC Aqua Matic 1800-2



Owner's Manual

Manual PN 6651140001 | Revision: B

Aqua Matic Compact 450-1800
Owner's Manual

Contents

Preface: About this Manual	i
About Sea Recovery	i
Purpose.....	i
Updates.....	i
References.....	ii
Graphics	ii
Notice of Liability.....	ii
Trademarks.....	ii
Terms and Conditions	ii
Copyright	ii
Revision History	iii
Chapter 1: Introduction	11
Welcome	11
Models	11
Parts Warning.....	12
Cleaning.....	13
Product Changes	13
Obtaining Warranty Service.....	13
Registration.....	13
Temperature and Pressure Effects.....	13
Safety.....	14
Disposal	14
Compliance	14
Chemical Warnings	15
Sea Recovery SRC SC Storage Chemical	15
Sea Recovery SRC MCC-1 Membrane Cleaning Chemical	15
Sea Recovery SRC MCC-2 Membrane Cleaning Chemical	15
Sea Recovery SRC MCC-3 Membrane Cleaning Chemical	16
Patent Information	16
Chapter 2: System Description	17
Pre-Installation Safety Checks	17
Storage Prior to Uncrating	17
Chemical Precautions	17
System Safety Check	17
Installer Minimum Qualifications	18
Warnings	18
System Specifications	19
Installer-supplied Components	19
Water Connections	20
Inlet Thru Hull Fitting (with Forward-facing Scoop).....	20
MNPT Connections	20
FNPT Connections	20
Circuit Breaker.....	20
Properly-sized Cables	20
Electrical Power Source	21
Piping and Interconnect Diagrams	21
RO Membrane Element(s)	21
Component Descriptions	22
Pre-filtration Components	22
Pressurization Components	24
Brine Discharge Components.....	24

Product Water Components	25
Fresh Water System Components	25
Fresh Water Flush Components	26
Electronic Components	26
Miscellaneous Components	27
Chapter 3: Electrical Specifications.....	29
Electrical Requirements and Specs	29
System Safety Check	29
Hazard Warning	29
Amperage Notes	29
Power Source Requirements	30
Motor Rotation	30
Electric Motor Specifications	30
Alternating Current Systems.....	30
Recommended Circuit Breaker Based on Operating Voltage	31
Recommended Power Wire Size to System	31
Recommended Power Wire Size to Booster Pump	31
Recommended Power Wire Size to High Pressure Pump	31
Chapter 4: Installation	33
System Frame	33
Component Mounting	33
Tube-Fitting Assembly	33
Interconnecting Components with Supplied Hose	34
Remote Touch Screen.....	35
Water Tank and Optional Components	35
UV Sterilizer	36
Install Fittings	36
Install Quartz Sleeve	37
Connect Plumbing	38
Install Ultraviolet Lamp	39
Mounting the Unit	39
Chapter 5: Commissioning	41
Check the Installation	41
Check RO Membrane(s)	41
System Valve Positions	42
Controller Setup	42
System Main Controller Update As Of 10/30/2017	47
System Commissioning	48
Display Setting	52
Setting System Clock	54
Setting System Run Timers	55
Setting System Salinity	59
Setting Fresh Water Flush	60
Manual System Check.....	63
Multi Media Filter Backwash and Rinse	64
Chapter 6: General Operation	67
Important Notes	67
New Systems	67
Freezing Temperature Warning	67
RO Membrane Element Warning	67
Fresh Water Flush Warning	68
System Storage	68
Powering the System ON	68
Automatic Mode	69

Manual Mode	69
Startup Sequence	70
Powering the System OFF	71
Automatic Mode	71
Manual Mode	71
System Short- and Long-Term Storage.....	72
Once-through Configuration	72
Closed-loop Configuration	72
System Main Controller Update As Of 10/30/2017	73
Manual Operation	74
Automatic Operation	80
Accessing Your Various Display Screens.....	83
Accessing System Fault & Warning Log	86
Accessing High Pressure Pump Hour Meter	87
Short-term Shutdown Procedure	89
Long-term Shutdown Procedure.....	90
Draining Component Water (for Winterizing)	91
Cleaning the RO Membrane	91
About New Systems	92
Reverse Osmosis Water and Cleaning Requirements	92
Cleaning Procedure	92

Chapter 7: Maintenance and Repair 95

Prerequisites	95
System Updates	95
Installer Minimum Qualifications	95
System Safety Check	96
Chemical Precautions.....	96
Note on Component Cleaning	96
Warnings	96
Weekly Quick Check	97
Operator Maintenance Intervals	97
Third-Party Parts Warning	97
Component Maintenance and Repair	98
Inlet Thru Hull Fitting	98
Sea Cock Valve	98
Inlet Connection	98
Sea Strainer	98
Electric Motor and Booster Pump Assembly	98
T-Connector Pressure Pick-Up	100
Pressure Transducers	100
Plankton Filter Element (Cleaning)	100
Multi Media Filter Backwash	100
Commercial or Dual Pre-Filter Element Replacement	101
Oil/Water Separator Filter Element Replacement.....	101
Transducer Manifold	102
Electric Motor and High-Pressure Pump.....	102
High Pressure Hose	103
Reverse Osmosis Membrane and Pressure Vessel Assembly.....	103
High Pressure Manifold	105
High Pressure Transducer.....	105
Automatic Motor Actuated Back Pressure Regulator	105
Brine Discharge and Product Water Flow Meters	106
Brine Discharge T-Connector	106
Brine Discharge Connector	106
Multi Media Filter Waste and Brine Discharge Tee	106
Thru-Hull Discharge Fitting	106
Product Water T-Collector	106
Salinity Probe	106

3-way Product Water Diversion Solenoid Valve	107
Charcoal Filter	108
pH Neutralizing Filter	108
Ultraviolet Sterilizer	109
Fresh Water Flush Carbon Filter Element	109
UV Sterilizer Maintenance	110
Exterior Surfaces	111
Quartz Sleeve	111
Checking for Leaks	111
Repairing Leaks	112
Measuring Performance	112
Verifying Lamp Operation	112
Obtaining Water Samples.....	112

Chapter 8: Troubleshooting 113

Alarm and Error Screens	113
Thru-Hull Inlet Fitting	114
Sea Cock Valve	114
Inlet Connection	114
Inlet Vacuum/Pressure Gauges	115
Sea Strainer	115
Booster Pump.....	115
T-Connector Pressure Pick-up	116
Pressure Transducers	116
Plankton Filter	116
Multi Media Filter	116
Dual Pre-Filter	117
Commercial Pre-Filter	117
Oil and Water Separator.....	117
Standard HP Pump Assembly	117
HP Pump Assembly.....	119
RO Membrane and Assembly	119
Automated Motor-Actuated Back Pressure Regulator	121
Brine Discharge Flow Meter	121
Salinity Probe	122
System Main Controller Update As Of 10/30/2017	123
System Fault Error Messages	124
System Warning Messages.....	129

Chapter 9: Glossary 133

Terms	133
-------------	-----

Chapter 10: Appendix 135

ABS Certificate of Design Assessment.....	136
ABS Certificate of Manufacturing Assessment.....	137
Declaration of Conformity	139
Management System Certificate"	140
Single-Phase Electrical Motor Wiring	141
Three-Phase Electrical Motor Wiring	142
Three Phase Transformer Wiring	143
New System Initial Readings Form	144
Daily System Readings	145

Chapter 11: Exploded Parts Views 147

Pre-Installation Matrix Drawing	148
---------------------------------------	-----

Chapter 12: Electrical Diagrams (Foldouts)211

About this Manual

About Sea Recovery

Since 1981, Sea Recovery Corporation has produced water desalination systems, used in various applications, for customers around the world. Currently, Sea Recovery Corporation stands apart as a leader in advanced water desalination systems for leisure marine applications.

Sea Recovery - USA
Parker Water Purification
2630 E. El Presidio Street
Carson, CA 90810



Purpose

This manual is intended for Sea Recovery's system technicians, technical support and training personnel. It contains technical information and instructions for the installation, operation, maintenance and troubleshooting of the system. Sea Recovery's RO desalination systems are designed and engineered to function as complete, working units and are subject to cascading failure if installation, operation and maintenance instructions are not followed correctly. Thus, the intent of this manual is to familiarize you, or other installer(s) and/or operator(s) with each system component. With a core understanding of the function, importance and normal operation of each subsystem component, you will be equipped to diagnose minor problems, which, if detected early on, are typically correctable. Note that if a minor component problem is left uncorrected, it can affect the rest of the system and lead to more extensive issues and/or damage.

 **Important:** Sea Recovery encourages you to read the manual thoroughly before attempting installation or operation, as well as to keep the manual for future reference. By gaining a better understanding of your system, you will be equipped with the knowledge to achieve optimum performance and a longer service life.

Updates

From time to time, Sea Recovery Corporation may make programming changes to the control logic. Other physical production changes may also be made, and are tracked by Sea Recovery Corporation through the System's serial number.

 **Remember:** Troubleshooting and repair method results can vary depending on the information that is displayed on the **SYSTEM INFORMATION** screen.

- **SERIAL NUMBER:** Helps Sea Recovery Corporation to determine the latest physical version and configuration of your System, ensuring that you are provided with correct part information.
- **TYPE:** Tells Sea Recovery Corporation the production capacity of your System, which provides a bench mark in diagnosing product water flow and pressure concerns.
- **VERSION:** Allows Sea Recovery Corporation to determine the specific sequential operation of the System based on the programming control logic version.



Depending on the issue, Sea Recovery Corporation may also request the System's operating Voltage, cycles and phase.

References

All references in this manual refer to sections within this manual, unless otherwise specified.

Graphics

Graphics used in this manual are for reference and illustration purposes only, and may not represent the actual part or arrangement of parts in a customized system.

Notice of Liability

The information contained in the manual is distributed on an "as is" basis, without warranty. While every effort has been taken in the preparation of this manual, Sea Recovery Corporation shall not be held liable with respect to any liability, loss or damage caused by the instructions contained in this manual. The information contained in this manual is subject to change without notice.

Trademarks

The Sea Recovery® logo mark is a U.S. Registered Trademark and belongs to Sea Recovery Corporation with all rights reserved. Sea Recovery® is a U.S. Registered trademark of Sea Recovery Corporation. Aqua Matic™ is a trademark of Sea Recovery Corporation.

Terms and Conditions

The use of this manual acknowledges acceptance of the terms and conditions provided herewith and the agreement to comply with all applicable laws and regulations pertaining to the use of this manual. In addition, the use of this manual forms an agreement that Sea Recovery's trademarked name or Sea Recovery's trademarked logo mark are not to be used in any form or manner except with Sea Recovery Corporation's written permission. Sea Recovery Corporation holds all rights to its copyrights and trademarks, and to the material contained in this manual. Any use of such requires the written permission from Sea Recovery Corporation.

Copyright

All content included within this manual, including text, graphics, logos and images, is the property of Sea Recovery Corporation and protected by U.S. and international copyright laws. The compilation (i.e., the preparation, collection, arrangement and assembly) of all content within this manual is the exclusive property of Sea Recovery Corporation and protected by U.S. and international copyright laws. All software used in the design and manufacture of the is the property of and protected by U.S. and international copyright laws. All computer and logic programming used

in the design and manufacture of the is the property of Sea Recovery Corporation and protected by U.S. and international copyright laws. The content of this manual and the software, programming, and graphics used in the design and manufacture of it is for the purpose of operation, maintaining and repair of the system. Any other use, including the reproduction, modification, distribution, transmission, republication, display or performance, of the content within this manual is strictly prohibited. © Copyright Sea Recovery Corporation 2008 - 2012.

Revision History

Rev #	Date	Affected Pages	Description
9	22 February 2018	12-13	Deleted Warranty Information
8	OCT 2017	All	Update to AQM III
7	May 2013	Parts View	Added HP75 & SoftStart
6	2011 August 31	All	Full revision of manual layout and content
5	March 30 2010	10-1 through 10-47	Updated drawings for exploded parts view
4	23 November 2009	5-2	Multi-media filter installation revision
3	22 September 2009	-	General layout and typesetting changes
2	4 September 2009	4-11 through 4-15, and fold-outs	Replaced wiring diagrams
1	3 August 2009	3-6 through 3-10	Additional installation option diagrams
0	1 December 2008	-	Initial release of 2008 models

Chapter 1

Introduction

Welcome

Congratulations on your purchase of a new Sea Recovery Aqua Matic Compact Reverse Osmosis (**RO**) Desalination System! The Aqua Matic RO Desalination System is engineered to be easier to use and more reliable than conventional water-makers. Featuring the latest technology, the System is able to regulate and monitor functions without the need of an operator.



Inside this manual, you will find detailed technical information and instructions for the installation, operation, maintenance and troubleshooting of your Aqua Matic RO Desalination System.

✔ **Note:** The term "System" refers to the Aqua Matic RO Desalination System and will be used throughout this manual.

Models

The Aqua Matic Compact series is available in the following six models: 450-1, 700-1, 900-1, 900-2, 1400-2 and 1800-2. Please note that your System also includes a system tag that lists the product name, model number and serial number.



Parts Warning

The major documented cause of failures and problems are from the use of third-party, non-Sea Recovery parts; improper installation; and improper operation. **Do not use parts, components from any source other than Sea Recovery!** The use of third-party, non-Sea Recovery parts is *strongly discouraged* and will result in the following consequences:

- The use of third-party, non-Sea Recovery components, spares and assemblies will damage the Sea Recovery System and/or specific components within the System.
- The use of third-party, non-Sea Recovery components, spares and assemblies will void any and all warranty of the System and/or void the affected component within the System.

🔍 Important: Sea Recovery Corporation maintains inventory for immediate shipment and our Service Dealers throughout the world maintain stock of Sea Recovery parts. Always insist on Sea Recovery supplied parts in order to avoid failures, eliminate problems, and maintain your warranty.

Cleaning

The is guaranteed to be cleanable for a minimum of one (1) year from date of shipment, providing cleaning periods are adhered to, and fouling is acid soluble metal hydroxides and calcium carbonates or alkaline soluble organic, inorganic substances and microbiological slimes. The Sea Recovery RO Membrane Element is not guaranteed against iron fouling (rust), chemical or petroleum products attack, extreme temperatures [over 120°F (49°C) under 32° F (0° C)], drying out, or extreme pressures [over 1000 psig (69 bar)]. In the event of a defect, a malfunction, or failure specifically covered by this warranty and during the warranty period, Sea Recovery Corporation will repair or replace, at its option, the product or component therein which upon examination by Sea Recovery Corporation appears to be defective.

Product Changes

Sea Recovery Corporation reserves the right to make changes or improvements in its product, during subsequent production, without incurring the obligation to incorporate such changes or improvements on previously manufactured equipment.

Obtaining Warranty Service

To obtain warranty service, the defective product or part must be returned to an authorized Sea Recovery Corporation Service Center or direct to Sea Recovery Corporation. An updated listing of Sea Recovery Corporation Factory Service Centers can be found on the Sea Recovery Corporation web site at <http://www.searecovery.com>. The purchaser must pay any transportation or labor expenses incurred in removing and returning the product to the service center or to Sea Recovery Corporation.

Registration

Sea Recovery Corporation recommends that all customers register their System immediately after delivery to ensure and guarantee product technical support and warranty.

Temperature and Pressure Effects



Note: Do not use this chart for brackish water systems and applications

As the sea water temperature gets higher, the pressure must be adjusted so that the System does not exceed 100% of its rated product water flow. Product water flow that is greater than 100% of rated capacity causes premature fouling of the RO Membrane Element, which *voids the RO Membrane Element warranty*. The System will also require more frequent cleaning. Please refer to the chart below for pressure adjustments.

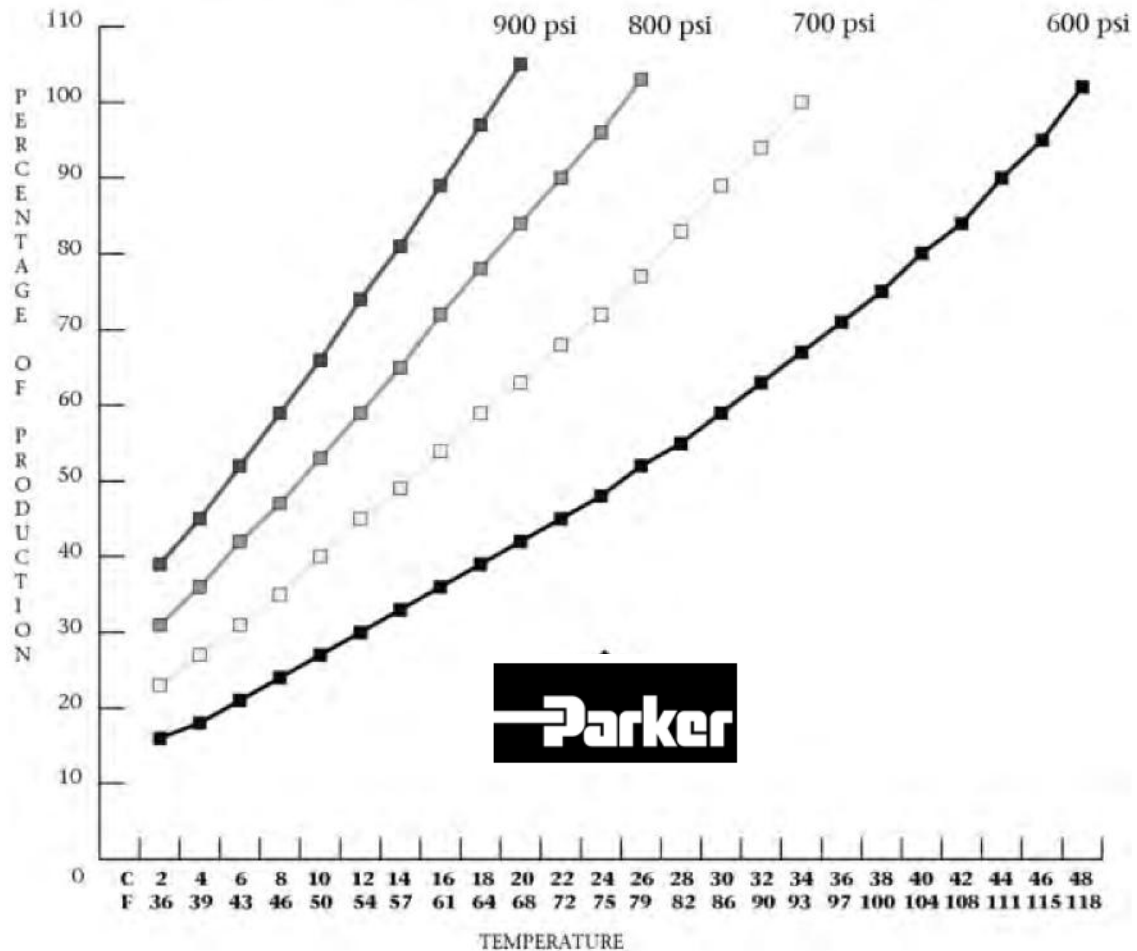
DO NOT EXCEED 100% OF RATED PRODUCTION!!!**Safety**

Parties responsible for the installation, operation, and maintenance of the must read this manual thoroughly and comply with the instructions and safety requirements at all times.

Disposal

If System disposal is necessary, you must comply with all federal and state environmental regulations.

Compliance

- Sea Recovery's Reverse Osmosis Desalination Systems are Type Accepted by the American Bureau of Shipping, ABS.
- Sea Recovery's Reverse Osmosis Desalination Systems comply with FCC § 15.105
- Sea Recovery's Reverse Osmosis Desalination Systems have been independently tested and determined to be in compliance with European CE (Conformité Européenne).

Please refer to the Appendix for copies of compliance certificates.

Chemical Warnings

Sea Recovery SRC SC Storage Chemical

WARNING! CONTAINS SODIUM METABISULFITE. HARMFUL IF SWALLOWED, AVOID BREATHING DUST & FUMES. CAUSES IRRITATION TO EYES & MUCOUS MEMBRANES. DO NOT TAKE INTERNALLY. KEEP AWAY FROM FOOD.

FIRST AID: IF SWALLOWED, CALL A PHYSICIAN, GIVE TAP WATER & INDUCE VOMITING. IN CASE OF CONTACT IMMEDIATELY FLUSH EYES WITH WATER FOR 15 MINUTES & GET IMMEDIATE MEDICAL ATTENTION. THOROUGHLY WASH AFFECTED SKIN AFTER HANDLING PRODUCT.

MEDICAL PERSONNEL FAMILIAR WITH Sea Recovery "SRC SC", SYSTEM & MEMBRANE STORAGE CHEMICAL, ARE AVAILABLE 24 HOURS A DAY, 7 DAYS A WEEK, U.S.A. TOLL FREE MEDICAL EMERGENCY NUMBER: 1-800-228-5635.

FOR INDUSTRIAL USE ONLY.

Use with adequate ventilation. Prevent breathing dust and prevent contact with eyes. Thoroughly wash contacted parts after handling. Do not allow powder to become wetted with small amounts of water. Adding small amounts of water to powder may liberate irritating sulfur dioxide gas. Add powder to above specified amount of water only. Do not mix with other chemicals or cleaners. If spilled, sweep up as much as possible then flush with water to drain.

KEEP OUT OF REACH OF CHILDREN

NET CONTENTS 1.5 POUNDS (.68 Kg)

Sea Recovery SRC MCC-1 Membrane Cleaning Chemical

WARNING: CONTAINS SODIUM METASILICATE. HARMFUL IF SWALLOWED. MAY CAUSE BURNS. AVOID CONTACT WITH EYES. AVOID PROLONGED CONTACT WITH SKIN. DO NOT TAKE INTERNALLY. KEEP AWAY FROM FOOD.

FIRST AID: IF SWALLOWED, CALL A PHYSICIAN, DO NOT INDUCE VOMITING, GIVE ONE GLASS OF TAP WATER OR MILK. IN CASE OF CONTACT IMMEDIATELY FLUSH EYES WITH WATER FOR 15 MINUTES & GET IMMEDIATE MEDICAL ATTENTION. THOROUGHLY WASH AFFECTED SKIN AFTER HANDLING PRODUCT. CONTACT A PHYSICIAN IF IRRITATION PERSISTS.

MEDICAL PERSONNEL FAMILIAR WITH Sea Recovery "SRC MCC1", R.O. MEMBRANE ELEMENT ALKALINE DETERGENT CLEANING CHEMICAL, ARE AVAILABLE 24 HOURS A DAY, 7 DAYS A WEEK, U.S.A. TOLL FREE MEDICAL EMERGENCY NUMBER: 1-800-228-5635.

FOR INDUSTRIAL USE ONLY.

Use with adequate ventilation. Prevent breathing dust & prevent contact with eyes. Thoroughly wash contacted parts after handling. Do not allow powder to become wetted with small amounts of water. Add powder to above specified amount of water only. Do not mix with other chemicals or cleaners. If spilled, sweep up as much as possible then flush with water to drain.

KEEP OUT OF REACH OF CHILDREN

NET CONTENTS 1.5 POUNDS (.68 Kg)

Sea Recovery SRC MCC-2 Membrane Cleaning Chemical

DANGER: CONTAINS SULFAMIC ACID. CAUSES BURNS, EYE & SKIN IRRITATION. HARMFUL IF SWALLOWED. AVOID BREATHING DUST. DO NOT TAKE INTERNALLY. KEEP AWAY FROM FOOD.

FIRST AID: IF SWALLOWED, CALL A PHYSICIAN, DO NOT INDUCE VOMITING, GIVE ONE GLASS OF TAP WATER OR MILK. IN CASE OF CONTACT IMMEDIATELY FLUSH EYES WITH WATER FOR 15 MINUTES & GET IMMEDIATE MEDICAL ATTENTION. THOROUGHLY WASH AFFECTED SKIN AFTER HANDLING PRODUCT. CONTACT A PHYSICIAN IF IRRITATION PERSISTS.

MEDICAL PERSONNEL FAMILIAR WITH Sea Recovery "SRC MCC2", R.O. MEMBRANE ELEMENT ACID CLEANING CHEMICAL, ARE AVAILABLE 24 HOURS A DAY, 7 DAYS A WEEK, U.S.A. TOLL FREE MEDICAL EMERGENCY NUMBER: 1-800-228-5635.

FOR INDUSTRIAL USE ONLY.

DO NOT MIX WITH CHLORINATED SOLUTIONS OR COMPOUNDS. Use with adequate ventilation. Prevent breathing dust & prevent contact with eyes. Thoroughly wash contacted parts after handling. Do not allow powder to become wetted with small amounts of water. Add powder to above specified amount of water only. Do not mix with other chemicals or cleaners. If spilled, sweep up as much as possible then flush with water to drain.

KEEP OUT OF REACH OF CHILDREN

NET CONTENTS 1.5 POUNDS (.68 Kg)

Sea Recovery SRC MCC-3 Membrane Cleaning Chemical

WARNING: CONTAINS SODIUM METABISULFITE. HARMFUL IF SWALLOWED. AVOID BREATHING DUST AND FUMES. CAUSES IRRITATION TO EYES AND MUCOUS MEMBRANES. DO NOT TAKE INTERNALLY. KEEP AWAY FROM FOOD.

FIRST AID: IF SWALLOWED, CALL A PHYSICIAN, GIVE TAP WATER AND INDUCE VOMITING. IN CASE OF CONTACT IMMEDIATELY FLUSH EYES WITH WATER FOR 15 MINUTES & GET IMMEDIATE MEDICAL ATTENTION. THOROUGHLY WASH AFFECTED SKIN AFTER HANDLING PRODUCT. CONTACT A PHYSICIAN IF IRRITATION PERSISTS.

MEDICAL PERSONNEL FAMILIAR WITH Sea Recovery "SRC MCC3", R.O. MEMBRANE ELEMENT RUST REMOVER CLEANING CHEMICAL, ARE AVAILABLE 24 HOURS A DAY, 7 DAYS A WEEK, U.S.A. TOLL FREE MEDICAL EMERGENCY NUMBER: 1-800-228-5635.

FOR INDUSTRIAL USE ONLY.

Use with adequate ventilation. Prevent breathing dust & prevent contact with eyes. Thoroughly wash contacted parts after handling. Do not allow powder to become wetted with small amounts of water. Adding small amounts of water to powder may liberate irritating sulfur dioxide gas. Add powder to above specified amount of water only. Do not mix with other chemicals or cleaners. If spilled, sweep up as much as possible then flush with water to drain.

KEEP OUT OF REACH OF CHILDREN

NET CONTENTS 1.5 POUNDS (.68 Kg)

Patent Information

Certain aspects of the are protected by U.S. and International Patent Laws.

Chapter 2

System Description

Pre-Installation Safety Checks

Ensure that you—as the Installer, Operator or both—read and understand the prerequisites, warnings and important notes within this topic.

Storage Prior to Uncrating

You must adhere to the following crate markings:

- **DO NOT** store in direct sunlight
- **DO NOT** store above 120°F (50°C)
- **DO NOT** allow the System to freeze (do not store below 32°F (0°C))
- **DO NOT** store longer than four (4) months without flushing with storage chemical
- Store only on base with **ARROWS UP**
- Keep the RO Membrane Element wet at all times

Chemical Precautions

Danger: The RO Membrane Element is susceptible to chemical attack. Take extreme caution in handling and storing! Do not expose your Aqua Matic RO Desalination System to feed water containing chemicals not approved in writing by Sea Recovery Corporation.

Do not connect a water line to your Aqua Matic RO Desalination System that may contain any of the following chemicals:

- Hydrogen peroxide chloramines-T
- Chlorine dioxide chlorine
- Bromine phenolic disinfectants
- Chloramines N-chloroisocyanurates
- Hypochlorite iodine
- Bromide petroleum products



Important: The use of non-authorized and/or the *misuse* of authorized chemicals will void your Sea Recovery Corporation warranty! For example, **DO NOT** connect the Aqua Matic RO Desalination System's inlet to your ship's potable water system if it contains chlorinated or brominated water. These chemicals destroy the copolymer components and the oxidants will damage the RO Membrane Element. In this situation, you can use the *optional* **Sea Recovery Fresh Water Flush Accessory** to remove the chlorine and bromine from your ship's potable water system before connecting the Aqua Matic RO Desalination System.

System Safety Check

Danger: Do not perform installation, maintenance or troubleshooting procedures until you have verified the following conditions:

-
- The System's Feed Water Sea Cock Valve is closed.
 - The System's main electrical disconnect switch is **OFF, LOCKED** and **TAGGED**.

Installer Minimum Qualifications

The System's Installer must have technical expertise in the following areas:

- Electrical, Electronic, Electric Motors and Circuits
- Electromechanical and Mechanical Systems
- Hydraulic and Liquid Pressure and Flow Systems
- Piping and Plumbing Systems
- Water Suction and Pressure Lines
- Thru-Hull Fitting below and above water level

Do not attempt maintenance and repair if you are not proficient in the aforementioned fields of expertise.

Warnings

Danger: ELECTRICAL SHOCK HAZARD The Aqua Matic RO Desalination System installation procedures expose the installer to high voltage and potential electrical hazards. Technicians should only attempt installation if (1) they are qualified electricians and (2) surrounding conditions are safe.

Caution: Do not attempt Installation, commissioning, troubleshooting, or repair of the unless you are proficient in the fields/functions listed within the section [Installer Minimum Qualifications](#) on page 18.

Caution: The RO Membrane Element is stored in sodium bisulfite. Avoid skin and eye contact with this packaging solution. If skin contact occurs, rinse skin thoroughly with water. If eye contact occurs, flush eyes repeatedly with water and notify a physician immediately.

Caution: Never mount the liquid holding component above any electrical or electronic device. Extensive damage to the electronic device will result if liquid enters device during maintenance and/or component failure.

 **Important:** Do not over-tighten PVC fittings. If threaded pipe fittings leak after installation, remove the fitting, clean the mating threads, apply three (3) to four (4) wraps of Teflon tape to the male threads, apply liquid Teflon pipe sealer sparingly, and thread the parts back together. PVC fittings should be hand tightened, without the use of a wrench.

 **Important:** The Sea Cock Valve, Inline Pressure Gauge, Sea Strainer, Rinse Clean Inlet Valve, and Booster Pump should be installed below water level. This will aid the Booster Pump in priming.

 **Important:** Always allow hoses and tubes to enter and exit straight from the connection *for a minimum of 1 in. prior to a bend*. If stress is placed on the fitting due to a tight bend, the fitting will leak and may break.

 **Important:** All connection lines should be as short and straight as possible using minimum fittings. Ensure that they are not "kinked".

 **Important:** Ensure that the power source is sufficiently sized to provide the correct voltage and cycles during System start up and operation.

 **Remember:** Install the system and its supporting components in an accessible manner.

System Specifications

Model	Prod. Water per Hour (U.S. Gallons / Liters)	Prod. Water per 24 hours (U.S. Gallons / Liters)	Weight (lbs / kg)
SRC Aqua Matic 450-1	19 / 71	450 / 1703	153 / 69
SRC Aqua Matic 700-1	29 / 110	700 / 2650	156 / 71
SRC Aqua Matic 900-1	38 / 142	900 / 3407	158 / 72
SRC Aqua Matic 900-2	38 / 142	900 / 3407	165 / 75
SRC Aqua Matic 1400-2	58 / 221	1400 / 5300	171 / 76
SRC Aqua Matic 1800-2	75 / 284	1800 / 6814	176 / 80

Specification	Value
Salt rejection (Chloride Ion)	99.4%
Product water temperature	Ambient to feed water temperature
Salinity monitoring	Automatic computer controlled electronic monitoring. The salinity monitoring components of the system give a continuous readout in micromhos per cubic centimeter, are temperature compensated and of a fail-safe design.
Salinity range of feed water	Seawater up to 50,000 PPM TDS (NaCl) (typical seawater salinity is 35,000 PPM)
Temperature range	Maximum 122°F / 50°C, Minimum 33°F / 0.5°C
Feed water flow per hour	225 U.S. Gallons / 852 Liters (AC 50 Hz); 270 U.S. Gallons / 1022 Liters (AC 60 Hz)
Reverse Osmosis (RO) membrane	Specifically selected High Rejection / High Yield aromatic tri-polyamide, thin film composite, spiral wound, single pass Reverse Osmosis membrane element.
Chlorine tolerance	0.1 PPM
pH range	3-11 (typical seawater pH is 8)

Minimum feed water pressure

6 psi	0.42 kg/cm ²	41.4 kPa
-------	-------------------------	----------

Maximum feed water pressure

40 psi	2.8 kg/cm ²	275.8 kPa
--------	------------------------	-----------

Nominal operating pressure (seawater @ 35,000 PPM, 77°F / 25°C)

800 psi	56.25 kg/cm ²	5516 kPa
---------	--------------------------	----------

External installation water connections (pip sizes to be supplied by the Installer for connection of the Sea Recovery supplied components)

- Feed Inlet - ¾ in. (19 mm) MNPT Male National Pipe Thread U.S. Standard
- Brine Discharge - ¾ in. (19 mm) MNPT Male National Pipe Thread U.S. Standard
- Product - ½ in. (12.7 mm) FNPT Female National Pipe Thread U.S. Standard

Installer-supplied Components

The components described in this topic are to be supplied by the Installer, based on the criteria provided by Sea Recovery Corporation.



Important: All fittings, valves and piping installed prior to, during, and after the Aqua Matic RO Desalination System installation *must not contain iron*. Should *iron* fittings, valves and/or piping be installed, then the resulting failure of the RO Membrane Element will be attributed to improper installation, and will be the liability of the Installer.

Water Connections

- Feed Inlet at the Sea Cock Valve: ¾ in. (19 mm) MNPT¹
- Brine Discharge at the Thru Hull Discharge fitting: ¾ in. (19 mm) MNPT
- Product at the Product Water Connector: ½ in. (12.7 mm) FNPT²
- Pressurized Fresh Water at the Cleaning Bucket: 3/8 in. (9.5 mm) FNPT

Inlet Thru Hull Fitting (with Forward-facing Scoop)

The Inlet Thru Hull Fitting must be a minimum ¾ in. (19 mm), and be dedicated to the Aqua Matic RO Desalination System. The Installer must utilize a forward-facing scoop, so that the system receives positive water flow when the ship is moving. The fitting must be installed on the ship's hull, in a position that provides a continuous, air-free supply of Feed Water.



Important:

- The Aqua Matic RO Desalination System must receive an uninterrupted supply of Feed Water without air.
- The Aqua Matic RO Desalination System must not be tied into an existing auxiliary water line that is already supplying another accessory on the ship.
- If the Aqua Matic RO Desalination System is connected to a Sea Chest or Stand Up Pipe, do not plumb the System's feed line to the "top" of either component. Plumb the System to the "bottom" of such feed water arrangements to ensure a continuous, air-free supply of Feed Water into the System.

MNPT Connections

- Inlet Sea Cock Valve Quarter turn ball valve (minimum ¾ in. (19 mm) MNPT connection) for mating to the supplied ¾ in. (19 mm) FNPT Inlet Connection fitting.
- Brine Discharge Thru Hull Fitting (minimum ¾ in. (19 mm) MNPT connection) for mating to the supplied ¾ in. (19 mm) FNPT Brine Discharge Connector fitting.

Caution: The Brine Discharge Thru Hull fitting must be installed above water level. Do not install any valve in the Brine Discharge line. A blockage or closed valve will cause damage to the System.

FNPT Connections

- The connection of the Product Water Line to the ship's *UNPRESSURIZED* Potable Water Storage Tank requires a ½ in. (12.7 mm) FNPT connection for mating to the supplied ½ in. (12.7 mm) MNPT Product Water Connector fitting. In order to avoid problems such as reverse flow (osmosis) from the tank to the System, as well as a chlorination attack on the RO Membrane Element, the fitting must terminate above the maximum water level. No valves should be installed in this line. A blockage or closed valve in the Product Water Line will cause damage to the System and the RO Membrane Element.
- The connection of the Fresh Water Flush sub-assembly to the ship's *PRESSURIZED* Potable Water Line requires a ¾ in. (19 mm) FNPT connection for mating to the ¾ in. (19 mm) MNPT fitting (which is supplied with the Fresh Water Flush subassembly).

Circuit Breaker

Circuit Breaker with appropriate amperage rating. Please refer to the topic [Electric Motor Specifications](#) on page 30 for details.

Properly-sized Cables

Properly-sized power cables. Please refer to the topic [Electric Motor Specifications](#) on page 30 for details.

¹ Male National Pipe Thread U.S. Standard

² Female National Pipe Thread U.S. Standard

Electrical Power Source

An electrical power source capable of delivering the required constant voltage and cycles during System start up and operation. Please refer to the topic [Electric Motor Specifications](#) on page 30 for details.

Piping and Interconnect Diagrams

Please refer to the [Appendix](#) on page 91 for diagrams (which include both *standard* and *optional* accessory configurations). In addition, diagrams depicting several pre-filtration configurations have been provided. Please follow the steps below when installing your System.

1. Determine pre-filtration and post-filtration components that must be installed.
2. Locate the appropriate diagram (see [Appendix](#) on page 91).
3. Connect the components based on the corresponding diagram.

RO Membrane Element(s)

Important: At times, Sea Recovery Corporation will ship an Aqua Matic RO Desalination System **WITHOUT** an RO Membrane Element installed. This is for the purpose of accommodating ship builders who want to install the System in advance of commissioning the ship.

To determine whether or not a RO Membrane Element has been installed, check the High Pressure Vessel(s) for a RO Membrane Element Serial Number tag (illustrated below).

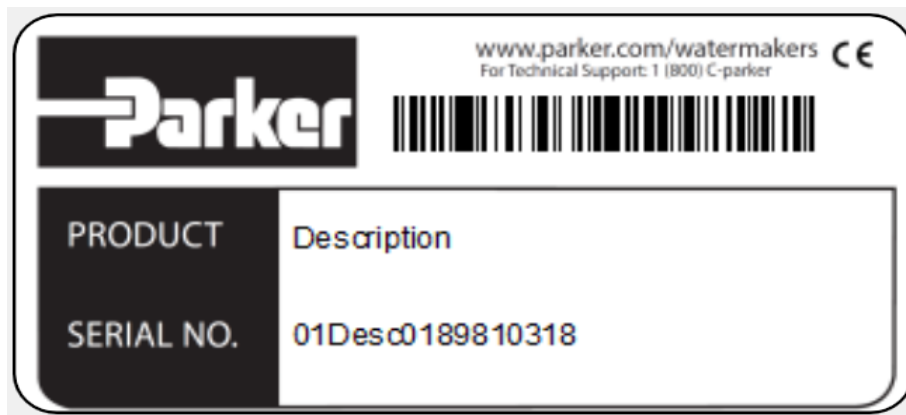

If the RO Membrane Element Serial Number tag is missing or does not contain a serial number and date, then the RO Membrane Element(s) are not installed. If the RO Membrane Element(s) are not installed, and you wish to install them at this time, then please contact Sea Recovery Corporation and supply us with your original Purchase Order Number, your Sea Recovery Corporation Invoice Number, and your System's Serial Number.

Important: If the RO Membrane Element is not to be installed at this time, ensure that you leave a visible note at the system controller and at the front of the control panel informing the end user that: The RO Membrane Element(s) are not installed; to contact the factory for the RO Membrane Element(s); and **DO NOT** operate the system without the RO Membrane Element(s) installed.

Caution: Extensive damage will occur if the system is operated without at least one RO Membrane Element installed. Damage to the system caused by the operation of the system without RO Membrane Element will be treated as follows:

- It will **NOT** be covered by the Sea Recovery Corporation warranty.

-
- It will be the Installer's liability, if he/she did not notify the System Owner.
 - It will be the System Owner's liability if the Installer properly notified he/she that the RO Membrane Element(s) were not installed and to not operate the system without the RO Membrane Element(s) installed.

Component Descriptions

All components supplied by Sea Recovery Corporation (both *standard* and *optional*) are described in this section, along with items required or optionally supplied by the Installer. The location, operation and purpose of each major component are briefly explained in this section. Remember, the major documented cause of failures and problems are from the use of third-party, non-Sea Recovery parts; improper installation; and improper operation. **Do not use parts, components from any source other than Sea Recovery!** Sea Recovery Corporation maintains inventory for immediate shipment and our Service Dealers throughout the world maintain stock of Sea Recovery parts. Always insist on Sea Recovery supplied parts in order to avoid failures, eliminate problems, and maintain your warranty. The use of third-party, non-Sea Recovery components, spares and assemblies will result in the following:

- Damage to the Aqua Matic RO Desalination System and/or damage to specific components within the System.
- Voiding the Aqua Matic RO Desalination System's warranty and/or voiding the affected System component's warranty.

Pre-filtration Components

The *Pre-filtration* section of your Aqua Matic RO Desalination System filters and delivers feed water. The raw feed water is filtered to remove suspended solids larger than 5 Microns (5/1,000,000 of a meter). Pre-filtration protects the High Pressure Pump from premature wear, and the Reverse Osmosis Membrane Element from premature fouling.

1. Inlet Thru Hull Fitting with Forward Facing Scoop

The point at which the Feed Water enters the system. The System's Installer must use a forward-facing scoop so that the System receives positive water flow as the ship is moving.

Caution: A flush Inlet Thru-hull Fitting will create a vacuum as the ship is moving, thus causing loss of Feed Water flow and cavitation of the Booster and High Pressure Pump. This will result in continuous system shut down.

Caution: The Installer must utilize a forward-facing scoop, so that the system receives positive water flow when the ship is moving. The fitting must be installed on the ship's hull, in a position that provides a continuous, air-free supply of Feed Water.

Caution: The resulting failure of the System to remain in operation is attributed to improper installation. Thus, it is the Installer's liability, and will not be covered by the Sea Recovery Corporation warranty.

2. Sea Cock Valve

Used (for safety reasons) to close the Feed Water line during repair, maintenance and disuse of the system.

3. Sea Strainer

Filters out large particulate matter and suspended particles that would otherwise damage the Booster Pump and prematurely foul the cartridge Pre-filter Element. The Sea Strainer has a clear bowl with a bronze body filter housing, that contains a cleanable, monel filter screen.

4. Booster Pump

Supplies positive pressure to the Pre-filters and onward to the High Pressure Pump. The Booster Pump has a performance curve of 85 Feet Head or 35 PSI (2.41 BAR) @ 60 Hz with a Feed Water flow of 4.5 GPM (17 LPM). The resulting pressure at the High Pressure Pump depends on the final installation configuration and condition of the Pre-filtration elements.

5. Low Pressure Transducer #1

Booster Pump Outlet / first Pre-filter Inlet for line pressure pick up from the outlet of the Booster Pump to the first Pre-filtration component.

6. **Plankton Filter** (*optional*)

Contains a cleanable, ultra-fine monel mesh screen. The mesh screen removes suspended solids or biological growth, such as plankton. It also provides longer life to the Pre-filter elements and, in turn, lowers system maintenance costs. The Plankton Filter is available as a single housing or dual housing. For additional information on obtaining this optional accessory, please contact Sea Recovery Corporation.

7. **Multi Media Filter** (*optional*)

Contains a back-washable bed of sand and gravel. The sand traps suspended solids larger than 30 microns, which provides longer life to the pleated cartridge, Pre-filter elements. As a result, maintenance intervals, maintenance labor and filter element costs will be reduced. For additional information on obtaining this optional accessory, please contact Sea Recovery Corporation.

Caution: Do not use third-party pre-filtration components! Use only Sea Recovery Corporation pre-filtration components. Third-party pre-filtration components do not fit properly, thus causing the seams to fall apart. They also allow bypass, which results in extensive damage to the High Pressure Pump, as well as to premature fouling of the RO Membrane Element.

8. **Dual Pre-Filter** (*optional*)

Removes suspended solids in two stages. The feed water passes first through a 20 micron cartridge then a 5 micron cartridge. By stepping the filtration, both pre-filter elements gain longer life and require less maintenance labor and pre-filter element replacement cost. For additional information on obtaining this optional accessory, please contact Sea Recovery Corporation.

9. **Commercial Pre-filter** (*optional*)

Takes the place of the Dual Pre-filter. The 5 micron Commercial Pre-filter cartridge element contains 37.5 sq. ft. (3.5 square meters) of filtering surface area. This oversized cartridge offers a longer filter-element life, which in turn, extends the time interval between required maintenance, as well as reduces maintenance labor and pre-filter element replacement costs. For additional information on obtaining this optional accessory, please contact Sea Recovery Corporation.

10. **T-Connector Pressure Differential Pick-up** (*optional*)

Included with the Pressure Differential Transducer for the line-differential pressure pick-up between the *optional* Pre-filtration components to the Low Differential Pressure Transducer. Depending on the Pre-filtration and System configuration, this T-Connector may not be necessary and only one of the two Pressure Pick-Up Tee styles may be used.

11. **Pressure Differential Transducer** (*optional*)

Used for line differential pressure across pre-filtration components. Allows the operator to determine which pre-filtration component requires servicing. For additional information on obtaining this optional accessory, please contact Sea Recovery Corporation.

12. **Oil/Water Separator Filter**

Removes oil present in the feed water.

Caution: Do not use third-party pre-filtration components! Use only Sea Recovery Corporation pre-filtration components. Third-party pre-filtration components do not fit properly, thus causing the seams to fall apart. They also allow bypass, which results in extensive damage to the High Pressure Pump, as well as to premature fouling of the RO Membrane Element.

Caution: Oil permanently destroys the RO Membrane Element. It is recommended that you avoid operating the Aqua Matic RO Desalination System in oil-polluted waters if the Oil/Water Separator Filter is not installed.

13. **Low Pressure Transducer #2** (*optional*)

Measures line pressure after pre-filtration has occurred (but prior to the inlet of the High Pressure Pump).

14. **Low Pressure Transducer Manifold**

Supports the Low Pressure and Differential Pressure Transducers.

Pressurization Components

The *Pressurization* section of your Aqua Matic RO Desalination System provides the necessary pressure to force the Product Water through the RO Membrane Element.

- 1. High Pressure Pump and Motor Assembly**
A positive-displacement Plunger Pump made of high-grade, stainless steel material. It is specifically designed for sea-water reverse-osmosis applications.
- 2. High Pressure Hose, HP Pump Outlet to RO Membrane Element, and Vessel Assembly Inlet**
Transfers pressurized sea water from the High Pressure Pump to the RO Membrane Element inlet.
- 3. RO Membrane Element and Vessel #1**
The RO Membrane Element allows potable water molecules to pass through, while rejecting salt ions. Depending on your System model, 7-28% of the seawater feed water will become freshwater. The remaining feed water transports the rejected salt ions out of the RO Membrane Element (in a concentrated brine stream). Note that your Aqua Matic RO Desalination System may have one *or* two RO Membrane Element(s) and Vessel(s) in series, depending on your specific model and System capacity.
- 4. RO Membrane Element and Vessel #2**
Connected in series with the first RO Membrane Element and Vessel. The Sea Recovery R.O. System will have either one or two RO Membrane Element and Vessel depending on the model. The 2nd RO Membrane Element and Vessel may be added at any time to a system with only one. Adding the 2nd RO Membrane Element and Vessel will double the System's production.
- 5. High Pressure Hose / RO Membrane Element and Vessel Assembly Outlet to High Pressure Manifold Inlet**
- 6. High Pressure Transducer**
Measures the System operating pressure from the outlet of the High Pressure Pump to the RO Membrane Element(s) and Vessel(s).
- 7. Back Pressure Regulator**
Controls the System operating pressure applied to the RO Membrane Element(s).
- 8. High Pressure Manifold**
Connects the High Pressure Hose, High Pressure Transducer, High Pressure Gauge and Back Pressure Regulator.

Brine Discharge Components

The *Brine Discharge* section carries the Brine Discharge water (exiting from the RO Membrane Element) back to the feed source.

- 1. Brine Discharge Flow Meter**
Measures the brine water flowrate from the RO Membrane Element in gallons or liters per hour. By adding the amount of Product Water flow to the Brine Discharge flow, the operator can determine the total Feed Water flow.
- 2. Brine Discharge T-Connector**
Collects the Brine Discharge water and unpotable Product Water.
- 3. Brine Discharge Connector**
Attaches to the overboard thru-hull fitting for connecting to the Brine Discharge Hose.
- 4. Multi Media Filter Waste "T"**
A component that is included with the *optional* Multi Media Filter. The Waste T is installed within the line (at the Brine Discharge fitting) for the purpose of discharging (1) waste from the Multi Media Filter (during backwash and rinse operations), and (2) Brine Water from the System.
- 5. Thru Hull Brine Discharge Fitting**
To be provided by the Installer. This fitting must be installed above water level for Brine Water discharge from the system.

Product Water Components

The *Product Water* section provides a visual indicator for the clarity, quantity and quality of the Product Water. Post-filtration is the final step in Product Water quality control. The Post-filtration Subsystem is designed to limit unpleasant odor and taste, adjust the pH to neutral and sterilize biological matter (which may have passed through the RO Membrane Element).

1. Product Water T-Connector

Combines the Product Water from two RO Membrane Elements.

2. Temperature Compensated Salinity Probe

Electronically determines whether the salinity content of the Product Water is acceptable. The Salinity Probe is temperature-compensated and provides an accurate measurement of Product Water quality.

3. Product Water Flow Meter

Electronically measures the Product Water flow rate in gallons or liters per hour.

4. 3-Way Product Water Diversion Valve (Electric Solenoid Actuated)

This valve is energized (by the Controller) into the potable position when the System produces water that meets the low salinity requirement. If the produced Product Water is un-potable (i.e., high in salinity), then no signal is sent to the valve and it remains in the normal-open position. The "fail-safe," normal-open position then diverts the un-potable Product Water to discharge.

5. Charcoal Filter

Removes foul odors from the Product Water. Sulfurous odor (i.e., "rotten-egg smell") is caused when biological matter dies and decays in the Feed Water section. Flushing the System with fresh water helps to minimize this odor.

6. pH Neutralizer Filter

Dissolves calcium carbonate into the Product Water, thus bringing the pH level back to neutral (i.e., at approximately pH 7).



Note: The pH value of pure water is pH 7, which is regarded as neutral. pH values from 0 to ~7 indicate *acidity*, while pH values from 7.25 to 14 indicate *alkalinity*. The Product Water from your Aqua Matic RO Desalination System will be slightly acidic because most of the naturally occurring, high-pH calcium carbonate has been removed. The Product Water from your System will also be soft (for the same reason mentioned above) at approximately 6.5 pH.

7. Ultra-Violet (UV) Sterilizer (optional)

Sterilizes at least 99.9% of viruses, bacteria and other micro-organisms that may pass through the RO Membrane Element. The UV sterilizer is recommended if the Product Water Storage Tank is not chlorinated or treated in another, similar manner. For additional information on obtaining this optional accessory, please contact Sea Recovery Corporation.

8. Product Water Connector

Connects the Potable Water Un-pressurized Tank to the Product Water Hose.

Fresh Water System Components

The Fresh Water system represents the ship's Fresh Water Pressurized System. Pressurized Fresh Water is required to supply the System Fresh Water Flush.

1. Potable Water Storage Tank

To be supplied by the System's Owner. This can be any container or existing storage tank that is suitable for storing Potable Water.

2. Fresh Water Pressure Pump

To be supplied by the System's Owner. Delivers Fresh Water throughout the ship.



Important: To provide the required water flow to the System during the Fresh Water Flush cycle, the pump must deliver up to 0.5 U.S. Gallons (1.9 Liters) per minute at 25 to 60 PSI (172 to 414 kPa).

3. **Air Entrainment Tank**

To be supplied by the System's Owner. This tank (also known as an accumulator) is sometimes installed into a ship's Fresh Water line to eliminate pulsations from the Fresh Water Pressure Pump, as well as to reduce the demand on the pump. The tank stores pressurized Fresh Water for delivery to the ship's fresh water piping.

Fresh Water Flush Components

The Fresh Water Flush section includes a Carbon Filter and an automatic, motor-actuated Ball Valve that automatically flushes the System with Fresh Water. This process occurs automatically every time the System shuts down, and repeats on a preset frequency (in days). Fresh Water Flushing replaces the sea water in the System with less corrosive fresh water, which also reduces the biological growth and subsequent decay that naturally occurs if the sea water is not flushed from the System with fresh water. For additional information on obtaining this optional accessory, please contact Sea Recovery Corporation.

1. **Fresh Water Flush 2-way Solenoid Valve**

Automatically actuates at System shut down (and at a preset frequency, in days) to flush the system with Fresh Water.

2. **Fresh Water Flush Check Valve**

Prevents Feed Water from entering the fresh water line.

3. **Fresh Water Flush Charcoal Filter**

Removes chlorine (if present) in the Fresh Water, prior to flowing through the RO Membrane Element.

4. **Cleaning Bucket**

To be supplied by the System's Owner. Can be any non-ferrous container capable of holding at least 10 U.S. Gallons (37.8 Liters) of water. This container is used during the RO Membrane Element cleaning, storing, or winterizing process.

5. **Rinse Clean Valves (optional)**

Mounted separately on singular individual plates or together on a double plate. The Rinse Clean Inlet Valve (used in conjunction with the Rinse Clean Outlet Valve) simplifies the storage and cleaning procedures by allowing the Operator to turn a valve, rather than disconnect a hose. Also used for manual Fresh Water Flush if the Automatic Fresh Water Flush System is not installed. Note that the Rinse Clean Valves are available on single or double valve mounting plates.

Electronic Components

The *Electronics* section measures water quality, controls the direction of Product Water flow, starts/stops the pumps, and contains the System's central electrical connection point. It also ensures that only potable Product Water passes into the Product Water Storage Tank.

1. **System Touch Panel**

Provides access to all System functions. Features an intuitive touch-screen and displays all operating conditions that are being monitored.

2. **Electrical Control Box**

Contains all electrical and electronic components that control the System.

3. **Remote Control Touch Panel (optional)**

Allows for remote control, operation, and monitoring of the system. For additional information on obtaining this optional accessory, please contact Sea Recovery Corporation.

4. **Soft Start (optional)**

Used only in AC Single Phase systems, this component reduces the initial start-up amperage that is required to turn on the High Pressure Pump Motor. Thus, a smaller KW generator can be used to start the system. Note that start-up amperage is reduced by 40% with the Soft Start installed. For additional information on obtaining this optional accessory, please contact Sea Recovery Corporation.

Miscellaneous Components

Note that the controller supports one tank-level switch. Please select either the low-level or high-level as described below.

1. Fresh Water Tank Low Level Switch

To be supplied by the System's Owner. Provides an optional feature to the System Control Logic that works in conjunction with the Automatic Fresh Water Flush option. When the Fresh Water Tank is empty, the switch is open. As water rises in the tank, the switch closes, which informs the System Control Logic that there is sufficient Fresh Water to perform the Automatic Fresh Water Flush Cycle.



Note: When installed and connected to the Main Printed Circuit Board, the Fresh Water Tank Low Level Switch must be connected as a Normally Open (NO), One Pole Single Throw (PST) switch.

2. Fresh Water Tank High Level Switch

To be supplied by the System's Owner. To be supplied by the System's Owner. Provides an optional feature to the System Control Logic that shuts off the System automatically Fresh Water Tank High Level Switch when the Fresh Water Tank is full (Note: System has to be operating in Automatic mode). Additionally, the System will not start in Automatic mode when the Fresh Water Tank High Level Switch signals the System Control Logic that the Fresh Water Tank is full. When the Fresh Water Tank is below the full mark, the switch is closed. As water rises and reaches the top of the full mark, the switch opens. This informs the System Control Logic that the Fresh Water Tank is full. If System operation is desired when the Fresh Water Tank Switch signals the System Control Logic that the Fresh Water Tank is full, then the System may be operated in Manual mode.



Note: When installed and connected to the Main Printed Circuit Board, the Fresh Water Tank High Level Switch must be connected as a Normally Closed (NC), One Pole Single Throw (PST) switch.

Chapter 3

Electrical Specifications

Electrical Requirements and Specs

The topics within this chapter address electrical requirements, safety information and specifications for the Aqua Matic RO Desalination System. For electrical schematics, please refer to the following diagrams in the Appendix:

- [Single-Phase Electrical Motor Wiring](#) on page 95
- [Three-Phase Electrical Motor Wiring](#) on page 96
- [Three Phase Transformer Wiring](#) on page 97

System Safety Check

Danger: Do not perform installation, maintenance or troubleshooting procedures until you have verified the following conditions:

- The System's Feed Water Sea Cock Valve is closed.
- The System's main electrical disconnect switch is **OFF, LOCKED** and **TAGGED**.

Hazard Warning

Danger: ELECTRICAL SHOCK HAZARD The Aqua Matic RO Desalination System installation procedures expose the installer to high voltage and potential electrical hazards. Technicians should only attempt installation if (1) they are qualified electricians and (2) surrounding conditions are safe.

Danger: Always allow slack in electrical cables. The cable must be able to enter and leave the strain relief in a straight manner to ensure proper connection; relieve stress on the cable and fitting; and to allow ease of detachment and re-attachment (for maintenance and/or replacement). If electrical cables are pulled tight and bent at the strain relief, then they may detach [from the strain relief]. The result is (1) a dangerous electrical-shock condition; wire breakage; and loss of the strain relief's water-tight integrity.

Amperage Notes

The electric motors within the Aqua Matic RO Desalination System start in series, with the time delay between each motor starting after the Touch Screen "Start" Switch is pressed.

1. First, the Booster Pump starts, then the main High Pressure Pump Electric Motor. Alternatively, the Booster Pump and High Pressure Pump may be started manually by accessing *manual operation mode* from the Touch Screen.
2. During start up, the Booster Pump Electric Motor's current surges to "Locked Rotor" amperage for a fraction of a second, after which, the current drops to a normal-running load. Then, the High Pressure Pump Electric Motor starts and surges to "locked Rotor" amperage for a fraction of a second, after which, the current drops to normal-running load.

Thus, the *maximum surge current* equals the **Booster Pump Electric Motor's** normal-running amperage *plus* the **High Pressure Pump Electric Motor's** starting amperage. *Normal-operational amperage* equals the **Booster**

Pump Electric Motor's normal-operating amperage *plus* the **High Pressure Pump Electric Motor's** normal-operating amperage.

Voltage (VAC)	Min. Voltage (VAC)	Max. Voltage (VAC)	Min. Power (HZ)	Max. Power (HZ)
120	108	132	58	62
230	207	253	58	62
100	90	110	48	52
220	198	242	48	52

Power Source Requirements

Check line voltage and frequency to ensure that it agrees with system nameplate. Grounding and circuit protection should be done in accordance with National Electrical Code. See connection diagram on nameplate of motor or refer to the diagrams within this manual.

Motor Rotation

Refer to Booster Pump and High Pressure Pump markings to determine proper rotation. For three-phase systems, you may ensure proper rotation by jogging each motor from manual operation mode.

Electric Motor Specifications

Abbreviations:

- HP = Horse Power
- RPM = Revolutions Per Minute
- FLA = Full Load Amperes
- LRA = Locked Rotor Amperes at startup

Alternating Current Systems

Single Phase Alternating Current (Oil Filled Pumps)

VAC	Hz	High Pressure Pump Motor				Booster Pump Motor			
		HP	RPM	FLA	LRA	HP	RPM	FLA	LRA
110	50	2	1450	21	109	0.5	2850	7.4	20
220	50	2	1450	10.5	54.5	0.5	2850	3.7	10
115	60	2.5	1750	21.2	109	0.5	3450	9.4	20
230	60	2.5	1750	10.6	54.5	0.5	3450	4.7	10

Three Phase Alternating Current (Oil Filled Pumps)

VAC	Hz	High Pressure Pump Motor				Booster Pump Motor			
		HP	RPM	FLA	LRA	HP	RPM	FLA	LRA
220	50	2.4	1450	8.2	30.9	0.5	2850	2.5	8.2
380	50	2.4	1450	4.1	15.45	0.5	2850	1.5	4.7
230	60	2.4	1750	7.2	30.9	0.5	3450	2.4	7.9
460	60	2.4	1750	3.6	15.45	0.5	3450	1.2	3.9

Alternating Current Systems

Single Phase Alternating Current (Oil Free Pumps)

VAC	Hz	High Pressure Pump Motor				Booster Pump Motor			
		HP	RPM	FLA	LRA	HP	RPM	FLA	LRA
110	50	3	2850	23	89	0.5	2850	7.4	20
220	50	3	2850	11.5	44	0.5	2850	3.7	10
115	60	3	3450	25.4	86	0.5	3450	9.4	20
230	60	3	3450	12.7	43	0.5	3450	4.7	10

Three Phase Alternating Current (Oil Free Pumps)

VAC	Hz	High Pressure Pump Motor				Booster Pump Motor			
		HP	RPM	FLA	LRA	HP	RPM	FLA	LRA
220	50	2.5	2850	7.9	24.9	0.5	2850	2.5	8.2
380	50	2.5	2850	4.6	14.4	0.5	2850	1.5	4.7
230	60	3	3450	7.6	23.8	0.5	3450	2.4	7.9
460	60	3	3450	3.8	11.9	0.5	3450	1.2	3.9

Recommended Circuit Breaker Based on Operating Voltage

Operating Voltage	Phase	Recommended Circuit Breaker (Ampere)
110-115 VAC	Single	50
220-230 VAC	Single	25
220 VAC	Three	15
380 VAC	Three	10
460 VAC	Three	10

Recommended Power Wire Size to System

Operating Voltage	Phase	Max Load (Amperes)	Recommended Minimum Wire Size for Run Length		
			10 ft / 3 m	25 ft / 8 m	50 ft / 15 m
110-115 VAC	Single	34.8	10 AWG / 6 mm ²	8 AWG / 10 mm ²	8 AWG / 10 mm ²
220-230 VAC	Single	17.4	12 AWG / 4 mm ²	12 AWG / 4 mm ²	12 AWG / 4 mm ²
220 VAC	Three	10.4	14 AWG / 2.5 mm ²	14 AWG / 2.5 mm ²	14 AWG / 2.5 mm ²
380 VAC	Three	6.1	14 AWG / 2.5 mm ²	14 AWG / 2.5 mm ²	14 AWG / 2.5 mm ²
460 VAC	Three	5	14 AWG / 2.5 mm ²	14 AWG / 2.5 mm ²	14 AWG / 2.5 mm ²

Recommended Power Wire Size to Booster Pump

Operating Voltage	Phase	Max Load (Amperes)	Recommended Minimum Wire Size for Run Length		
			10 ft / 3 m	25 ft / 8 m	50 ft / 15 m
110-115 VAC	Single	9.4	14 AWG / 2.5 mm ²	14 AWG / 2.5 mm ²	14 AWG / 2.5 mm ²
220-230 VAC	Single	4.7	14 AWG / 2.5 mm ²	14 AWG / 2.5 mm ²	14 AWG / 2.5 mm ²
220 VAC	Three	2.5	16 AWG / 1.5 mm ²	16 AWG / 1.5 mm ²	16 AWG / 1.5 mm ²
380 VAC	Three	1.5	16 AWG / 1.5 mm ²	16 AWG / 1.5 mm ²	16 AWG / 1.5 mm ²
460 VAC	Three	1.2	16 AWG / 1.5 mm ²	16 AWG / 1.5 mm ²	16 AWG / 1.5 mm ²

Recommended Power Wire Size to High Pressure Pump

Operating Voltage	Phase	Max Load (Amperes)	Recommended Minimum Wire Size for Run Length		
			10 ft / 3 m	25 ft / 8 m	50 ft / 15 m
110-115 VAC	Single	25.5	12 AWG / 4 mm ²	10 AWG / 6 mm ²	10 AWG / 6 mm ²
220-230 VAC	Single	12.7	14 AWG / 2.5 mm ²	12 AWG / 4 mm ²	12 AWG / 4 mm ²
220 VAC	Three	7.9	14 AWG / 2.5 mm ²	14 AWG / 2.5 mm ²	14 AWG / 2.5 mm ²
380 VAC	Three	4.6	14 AWG / 2.5 mm ²	14 AWG / 2.5 mm ²	14 AWG / 2.5 mm ²
460 VAC	Three	3.8	14 AWG / 2.5 mm ²	14 AWG / 2.5 mm ²	14 AWG / 2.5 mm ²

Chapter 4

Installation

Caution: All mounting surfaces must be flat in order to avoid bracket and frame warping. Damage caused by attaching the System (or its components) to an uneven surface *will be attributed to improper installation; is the liability of the Installer; and is not covered* by the Sea Recovery Corporation warranty. Grind mounting surfaces flat, or use appropriate shims on uneven surfaces, to ensure that System component mounting does not cause bending or warping.

System Frame

The System frame must be placed in a location that allows the following:

- Safe and convenient operation and maintenance access.
- Sufficient room for Filter Bowl removal.
- Safe and convenient access to the right side of the frame for electrical wire attachment.
- Touch-pad access (i.e., it is both reachable and readable).

 **Note:** The System frame is mounted in-place by four (4) rubber-isolation mounts (supplied). Four (4) threaded bolts and four (4) sheet-metal screws are provided for attachment.

1. Lay the System frame on a flat surface and mark the mounting holes.
2. Temporarily move the System frame, and drill the appropriate holes (depending on the hardware that you are using).
3. Place the System frame over the drilled holes and attach the rubber isolation grommet under the frame at each of the four (4) mounting points.
4. Place the mating, rubber-isolation grommet on top of the frame hole, and attach it with the appropriate supplied washers, bolts and screws.

Component Mounting

Tube-Fitting Assembly

The following tasks provide guidance on tube-fitting assemblies. A general diagram is displayed below.



Caution: If water lines are pulled tight and, thereby, bent at the fitting, they can leak, allow air to enter, fail prematurely, and/or break the attached fitting. Always allow slack in tube and hose lines. Never cause a bend in the tube or hose to at the fitting. The line must enter or leave the fitting in a straight manner for several

inches to ensure proper connection, relieve stress to the fitting and tube/hose, and allow easy detachment and re-attachment during maintenance or repair.

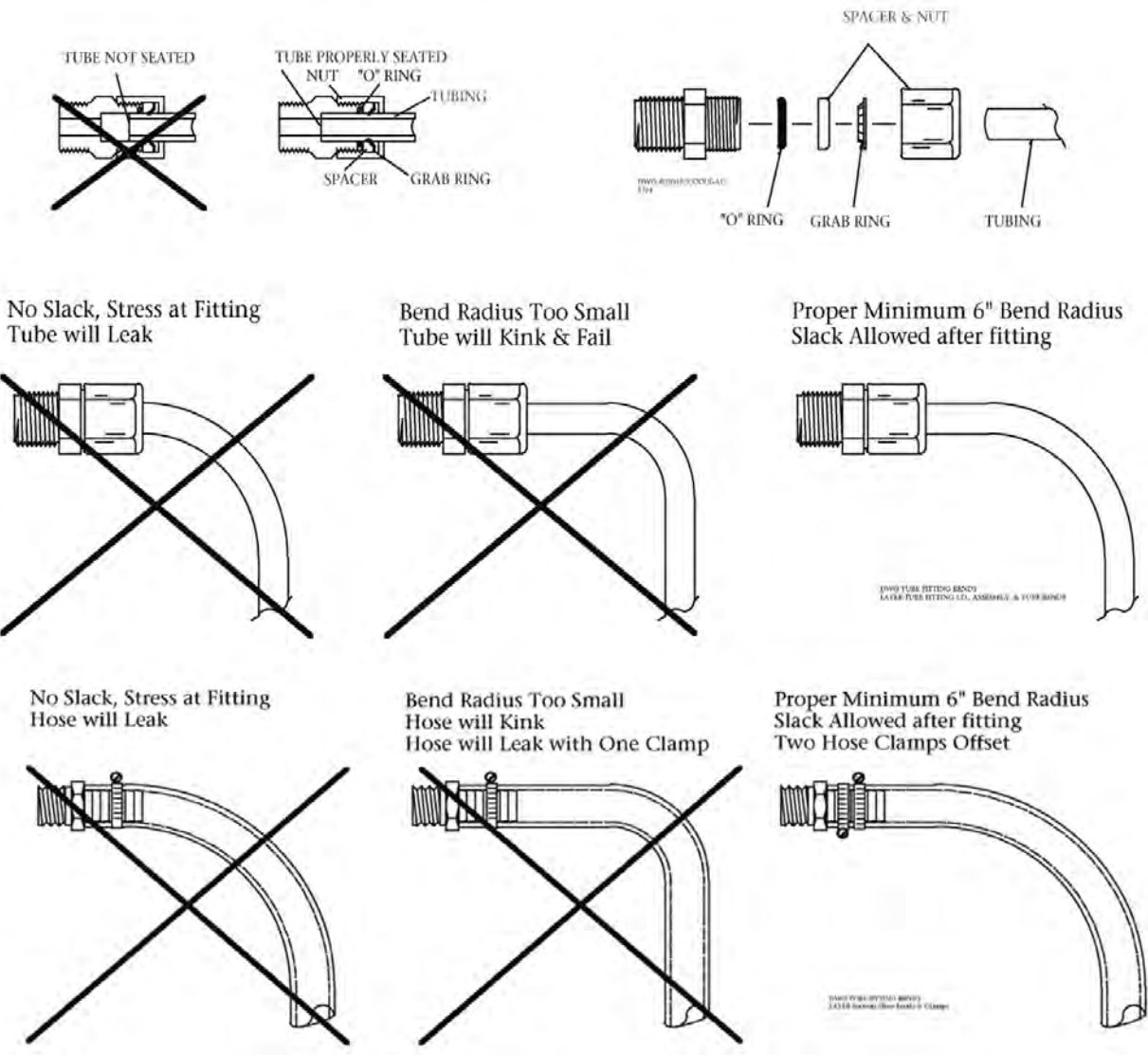

1. Cut tube-end squarely and cleanly.
2. Loosen nut by three turns on the fitting.
3. Insert tube into the fitting until it bottoms.
4. Loosen nut completely and remove tube with attached parts from body.
5. Check that the O-Ring is seated under the tube's spacer, and not pinched into its body.
6. Insert tube with attached parts into the body and tighten nut finger-tight.

Interconnecting Components with Supplied Hose

- ✔
Note: ¼ in. (6.35 mm) OD, nylon tubing is supplied with applicable components for connecting pressure pick-up points to the Low Pressure Transducers. Use of this tubing is dependent upon the optional Pre-filtration components installed in your System.

 **Important:** If the RO Membrane Element and Pressure Vessel Assembly are mounted remotely, ensure that all high-pressure hoses have sufficient slack and are not pulled tightly into a sharp or immediate bend.

1. Using the supplied ¾ in. (19 mm) ID, clear, braided hose, connect the Suction Line components, Low Pressure line components and Brine Discharge Line components. Secure connections with the supplied hose clamps. Ensure that all Suction Hose connections use two (2) hose clamps that have been rotated 180°, with the screw heads facing the same direction. Using fine sandpaper, remove any flash from the hose-barb fittings. If your System is not supplied with one or more of the optional components mentioned, then skip it and make a connection to the next supplied component.
2. Using the supplied 50 feet (15 meters) of ½ in. (12.7 mm) ID, clear, braided hose, connect the Product Water Line components. Secure each connection with the supplied hose clamps, placing one (1) hose clamp onto each hose-barb fitting.

Component Interconnect Chart

Component Outlet	To Component Inlet
Inlet Connection	Sea Strainer
Sea Strainer	Rinse Clean Inlet Valve left or right port
Rinse Clean Inlet Valve unused left or right port	Rinse/Clean Container
Rinse Clean Inlet Valve center port	Booster Pump
Booster Pump	Pre-filtration Options
Pre-filtration Options	LP Manifold
Brine Discharge Tee	Rinse Clean Discharge Valve
Rinse Clean Discharge Valve	Cleaning Bucket
Rinse Clean Discharge Valve	Brine Discharge Connector
Multi Media Filter Waste Line (if used)	Multi Media Filter Discharge Fitting separate Thru-Hull or Tee at Brine Discharge Connector
pH Neutralizing Filter	Ultra Violet (UV) Sterilizer
Ultra Violet (UV) Sterilizer	Potable Water Storage Tank or Cistern

Remote Touch Screen

The Remote Touch-Screen Enclosure Assembly is supplied with an 80 ft (24.4 m) long, NMEA-200 cable for connection to the Main Control Panel. Place and install the Remote Touch-Screen Enclosure in a location that meets the following criteria:

- Away from water lines and hoses.
- Away from locations that could be sprayed with water.
- In an accessible and viewable location.
- Within 80 ft (24.4 m) of the Main Control Panel.

Water Tank and Optional Components

 **Note:** These optional components are installed inside the Fresh Water Tank. The high- and low-level tank switches are not mandatory for System operation; however, they do add features when the System is in Automatic mode. The choice of make, model and style are left up to the Installer and/or Owner. The switches must meet the electrical requirements and operations described below. The Installer may also connect an *optional*, external alarm to the System, which will alert the Operator when the System shuts down.

Optional Component (<i>Owner/Installer-supplied</i>)	Description
Fresh Water Tank Low Level Switch	Provides an <i>optional feature</i> to the System Control Logic that works in conjunction with the Automatic Fresh Water Flush option. When installed and connected to the Main Printed Circuit Board, the Fresh Water Tank Low-Level Switch must be connected as a Normally Open (NO), One Pole Single Throw (1PST) switch. When the Fresh Water Tank is empty, the switch is open. As water rises in the tank, the switch closes. This informs the System Control Logic that there is sufficient Fresh Water to perform the Automatic Fresh Water Flush Cycle.
Fresh Water Tank High Level Switch	Provides an <i>optional feature</i> to the System Control Logic that allows the System to shut off automatically when the Fresh Water Tank is full (as long as the System is operating in Automatic mode). Additionally, the System will not start when the Fresh Water Tank High Level Switch signals to the System Control Logic that the Fresh Water Tank is full. When installed and connected to the Main Printed Circuit Board, the Fresh Water Tank High Level Switch must be connected as a Normally Closed (NC), 1PST switch. When the Fresh Water Tank is below the full mark, the switch is closed. As water rises and reaches the top of the full mark, the switch opens, which informs the System Control Logic that the Fresh Water Tank is full. The System shut downs if operating in Automatic mode, and will not start if operating in Automatic mode. If System operation desired when the Fresh Water Tank Switch signals to the System Control Logic that the Fresh Water Tank is full, then the System may be operated in Manual mode.
Alarm	Provides an <i>optional feature</i> to the System Control Logic that audibly or visually signals to the Operator that the System has stopped running. The alarm circuit output from the Main Printed Circuit Board is 12 VDC with MAXIMUM allowable current consumption of one (1) Ampere. This alarm will signal if a fault occurs. It will not signal with a normal shut down (i.e., one that was not associated with a fault).

UV Sterilizer

The following steps describe the assembly and installation process for the Ultraviolet (UV) Sterilizer component. The SP-Series UV unit is shipped with a UV lamp, quartz sleeve, fittings, and O-rings, and must be assembled before it can be used with your Aqua Matic RO Desalination System. The UV Sterilizer unit must be installed in accordance with the following conditions/parameters:

- Install the unit in a sheltered, well-ventilated area.
- Install the unit as close as possible to the point-of-use, in order to avoid potential contamination discharge from pipes, fittings, etc.
- Mount the unit on a stable support to avoid straining or warping.
- Allow sufficient clearance around the unit for servicing.
- Ensure the installation location is free from vibration.
- Properly ground the unit to ensure safe operation. **Failure to properly ground the UV unit automatically voids all unit warranty.**
- Ensure that the line voltage is between 10.56V and 16.50V. Voltage outside this range will compromise the unit's performance.
- Ensure that the operating pressure does not exceed the maximum operating pressure of 50 psig (8.24 bar).
- All piping, tubes and hoses leading to the UV unit's connection points must be leak-free. Please verify before performing the assembly/installation procedures.
- The UV unit may be installed horizontally or vertically. For vertical installation, ensure that the inlet port is positioned at the bottom.

Caution: Do not assemble or install damaged parts! Quartz sleeve and UV lamp are fragile and must be handled with care.

Install Fittings

Perform the procedure below to prepare the UV unit for installation.

1. Inspect each port and fitting to ensure that the threads are free of dirt, burrs and excessive nicks. If threads are badly nicked, replace the fitting.

2. Wrap ¼ in. (6.35 mm)-wide, PTFE tape counter-clockwise (2 to 3 turns) around the male threads of the ¼ in. (6.35 mm) fitting. **DO NOT** wrap tape around the first thread.
3. Finger-tighten the fitting into the cylinder ports to achieve desired alignment.

 **Important:** Do not back-off fitting. Do not over-tighten fitting. Over-tightening could strip the fitting threads and cause a leak.

Install Quartz Sleeve

 **Important:** Perform this procedure only when water piping for UV unit is in-place and ready for service.

1. Visually inspect quartz sleeve for cracks and damages.
2. Remove the ballast box cover. Remove the four (4) screws holding the ballast box cover, then remove the cover.

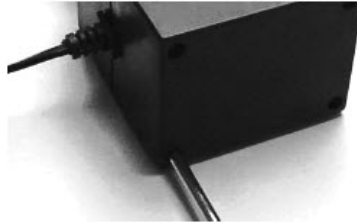

3. Remove the rubber boot and pull out the 4-point lamp connector.

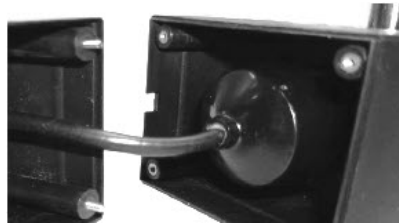

4. Remove the compression nuts.



5. Insert the quartz sleeve. Place the closed end of the quartz sleeve into the cylinder through the ballast-box pass-thru. Leave ½ in. (12.7 mm) of the quartz sleeve to expose on the viewport pass-thru.

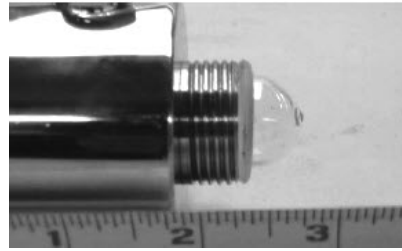
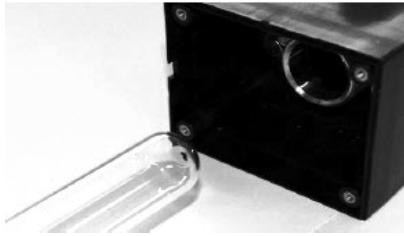

6. Lubricate the tips of the quartz sleeve with clean water and insert new O-Ring. Ensure that the O-Ring makes all-around contact with the cylinder pass-thru.
7. Tighten the compression nut while ensuring that the nut does not contact the quartz sleeve. Adjust O-Ring position as necessary. The compression nut should be snug and tight, not over-torqued.
8. Repeat the previous two Steps 6 and 7 on the ballast-box compression nut.

Connect Plumbing



Important: Tube or hose ends must be cut squarely and cleanly, without rough edges. The quick-fit elbow fitting has a C-clamp that will lock the tube in place, once inserted.

1. Insert the supply pipe into one (1) cylinder port and label the port "Inlet."
2. Insert the temporary pipe into the other cylinder port to direct water into a container.



3. Slowly fill the cylinder with water and flush cylinder for one (1) minute.



4. Remove temporary pipe and insert the return pipe into the cylinder port, then label the port "Outlet."
 5. Slowly pressurize the UV unit by filling the cylinder with water while checking for leaks.
 6. If leaks are found on the compression nuts, depressurize the unit and slightly tighten the leaking compression nut.
 7. Retest until a leak-free installation has been verified.
- Once the UV unit is leak-free, the quartz sleeve installation is complete. The UV lamp can now be installed.



Note: To remove the tube from the fitting, first remove the C-clamp, then push the fitting sleeve downward. Once the fitting sleeve is down, pull the tube out of the fitting.



Install Ultraviolet Lamp

Important: Perform this procedure only after the quartz sleeve installation and leak-tests are completed successfully.

1. Connect the UV lamp to the 4-point receptacle. **If the lamp is not installed properly, lamp breakage will occur.**



2. Insert lamp into quartz sleeve through compression-nut pass-thru.

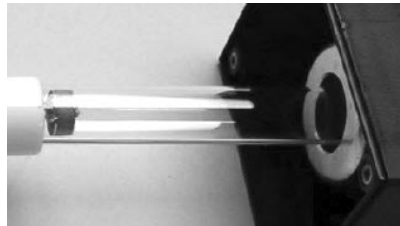

3. Install rubber boot over compression nut.
4. Connect unit power cable to power source.
5. Tighten the four (4) screws to secure the ballast box cover.
6. Prior to energizing the lamp, ensure that there is no water leaking from the quartz sleeve compression nuts. Then, turn power **ON**.

Caution: Rapid successive cycling of the power to the ballast can cause premature failure of the unit.

7. Verify UV lamp operation from the viewport. Use the viewport to verify the proper operation of the UV lamp. Allow one minute for the UV lamp to warm up prior to flowing water through the UV unit.

Mounting the Unit

Once the UV unit is assembled and tested successfully, it can be mounted onto its permanent operational location. The unit must be mounted in a manner that will prevent excessive vibration and warping (which will damage the quartz sleeve). Ensure that the following conditions are met when mounting/operating the unit:

- Release the pressure in the UV treatment chamber before breaking the compression nut seals.

-
- Disconnect all power to the UV unit before servicing.
 - Do not allow the inlet water temperature to drop below 35°F (2°C).
 - Do not allow the flow rate to exceed 2 GPM (7.5 LPM).
 - Do not cycle the UV unit more than three "ON/OFF" cycles in one 24-hour period.
 - Ensure all plumbing connections are tightly sealed before applying pressure.
 - Before connecting the return tube, flush the unit to rinse out any debris left from the installation process.

Danger: UV light exposure can severely burn and damage eyes and skin

Danger: DO NOT look at the blue UV light. DO NOT operate the UV lamp outside of the UV treatment chamber.

Danger: The unit operates on high voltage and must be serviced by qualified personnel only.

Caution: Cycling more than 3 cycles will reduce the end-of-life (EOL) output and/or cause premature lamp failure.



Important: Standard flow rates are based on a water temperature of 35°F to 100°F (2°C to 38°C) . If the inlet water temperature exceeds 100°F (38°C), please contact your local CSR.

Chapter 5

Commissioning



Important: These procedures **must** be carried out for the initial start-up of a **new** system. Failure to follow these instructions can lead to System and component damage.

Check the Installation

Verify that the System has been installed properly, based on the checkpoints below. In addition, complete the [New System Initial Readings Form](#) on page 98 and retain it with your Owner's Manual.



Remember: Damage caused to the system due to operation of an improperly installed system is the liability of the Installer and the Operator, and is not covered by the Sea Recovery Corporation warranty.

- Check each water connection to the System to ensure that the Installer has properly connected and routed each tube. Improper routing and/or line blockage will cause System damage. Improperly connected and/or loosely connected lines that result in leaks and/or damage are the liability of the Installer and the Operator, and are not covered by the Sea Recovery Corporation warranty.
- Do not assume and do not rely on the Installer's word; check the System installation yourself.
- Ensure that the Electrical Power Source and the ship's System circuit breaker is switched **OFF** position.
- Open the Electrical Control Box and verify all electrical and electronic connections. Check for proper wiring and attachment. After checking all wiring for proper attachment, close the Electrical Control Box.
- Switch the Electrical Power Source and the ship's System circuit breaker to the **ON** position.

Check RO Membrane(s)



Important: At times, Sea Recovery Corporation will ship an Aqua Matic RO Desalination System **WITHOUT** an RO Membrane Element installed. This is for the purpose of accommodating ship builders who want to install the System in advance of commissioning the ship.

Verify that the RO Membrane Element(s) have been installed properly within the Pressure Vessels. If the RO Membrane Element has been installed, there will be an RO Membrane Element Serial Number tag attached to the High Pressure Vessel. If the RO Membrane Element Serial Number tag is missing or does not contain a serial number and date, then immediately contact the company that sold the System to you, the Installer, or Sea Recovery Corporation.

Caution: DO NOT attempt to operate the System without an RO Membrane Element installed, otherwise *extensive damage* will result. Damage caused to the System due to an incorrectly installed RO Membrane Element(s) is the liability of the Installer and the Operator, and is not covered by the Sea Recovery Corporation warranty.

System Valve Positions

- 
Note: The Inlet Thru-Hull Sea Cock Valve is in the **OPEN** position. It is recommended (for ship safety) that you close the Sea Cock Valve whenever the System is not in use. This will protect the ship from flooding, should a hose or component fail.

Valve	Position
Inlet Sea Cock Valve	Full Open
Rinse Clean Inlet Valve	From Sea Strainer to Fresh Water Flush Valve
Rinse Clean Outlet Valve	From System brine discharge to Thru Hull Discharge Fitting
Multi Media Filter Valves	Normal Operation
ANY auxiliary valve in the Feed Line, Brine Discharge Line or Product Water Line	Full Open

Caution: If an auxiliary valve is installed within these lines and is closed during System start and/or operation, it will damage the System. The resulting damage is the liability of the Operator and is not covered by the Sea Recovery Corporation warranty.

Controller Setup

The controller is set by Sea Recovery Corporation prior to shipping, based on the ordered System features and optional equipment. The addition of the Fresh Water Flush to the System after it has shipped from Sea Recovery requires updates to the computer logic setup. The addition of, removal of, or changes to the length of the RO Membrane Element / Pressure Vessel Assembly requires updates to the control logic setup. Please refer to the *Programming Kit Manual* for details. The information below is an explanation of Operator-programmable features. Each feature must be set properly in order to gain maximum System performance. Only pre-installed features will be displayed on the screen.



- 1. Manual Mode:** Enables user to control the Booster Pump, HP Pump, Diversion Valve and Pressure.

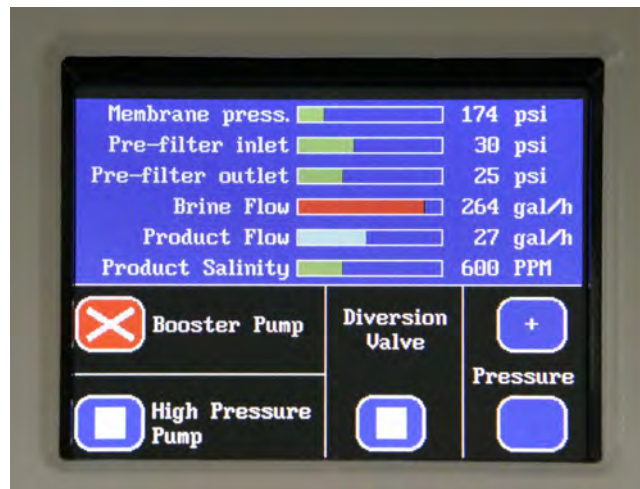

- Manually start and stop the Booster Pump.
 - Manually start and stop the High Pressure Pump.
 - Manually energize the 3-Way Product-Water Diversion Valve at a specific product-water quality, in Parts per Million (PPM). The factory setting is 800 PPM Total Dissolved Solids (TDS), expressed as NaCl (i.e., Sodium Chloride, or salt).
 - Manually control the System pressure by increasing or decreasing the back point pressure regulator set point.
2. **Display:** Change the Touch Screen's color contrast for better viewing.



3. **Accepted Salinity Level:** Change the accepted salinity level by adjusting the PPM level.

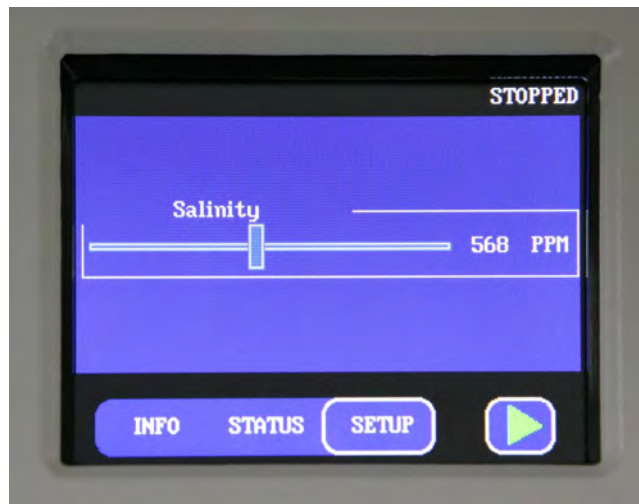

4. **Back Wash Time:** Change the interval for automatic back washing by adjusting the number of days.



5. **Language:** Change the current controller language by selecting new language option.



6. **Unit:** Toggle the measurement standards between U.S. Standard and Metric Standard.



- a) Pressure: U.S. Standard = PSI (Pounds Per square Inch); Metric Standard = kPa (kilo Pasquel)
- b) Flow: U.S. Standard = GPM (Gallons Per Minute) or GPH (Gallons Per Hour); Metric Standard = LPM (LitersPer Minute) or LPH (Liters Per Hour)

SYSTEM MAIN CONTROLLER UPDATE AS OF 10/30/2017

System Commissioning

The Aquamatic, Aquamatic XL and AquaWhisper desalination system controller comes loaded with a special utility tool designed to aid the dealer in the commissioning of the system. This utility can be used to set a limited number of options within the controller, and is accessed in the following manner.

NOTE: Your system should not be running when attempting to enter dealer commissioning mode.

CAUTION: All electrical covers should be on before providing powering to the system. Electrical shock may accrue if electrical boxes are exposed.

1. Press Anywhere on the Main Splash screen to begin.
2. Press the indicated area to gain access to the system information area.
3. On System Overview Screen press and hold the indicated area for at least 2 seconds to gain access to the 'System Additional Functions' menu area.

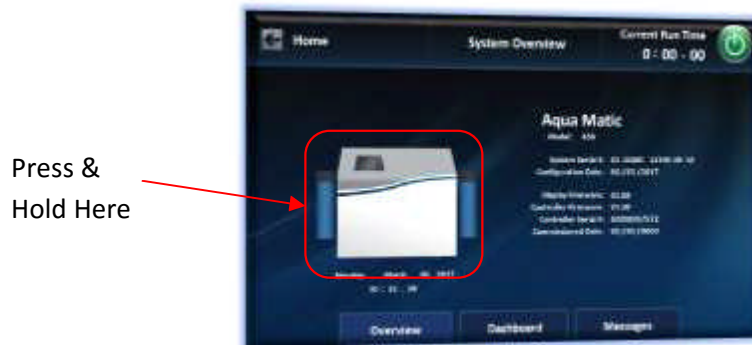

4. Log in using your dealer user name and password in the area shown below

NOTE: Password is case sensitive

5. Press System Configuration shown below

6. Select or Enter in SYSTEM TYPE, SYSTEM FREQUENCY, SYSTEM SIZE, and CURRENT TIME.

	Aqua Matic	Aqua Whisper DX	Aqua Matic XL
SYSTEM SIZE RANGE	450-1800	450-1800	2200-3400
SYSTEM FREQUENCY	50 or 60 Hz	50 or 60 Hz	50 or 60 Hz
CURRENT TIME	24 Hour	24 Hour	24 Hour

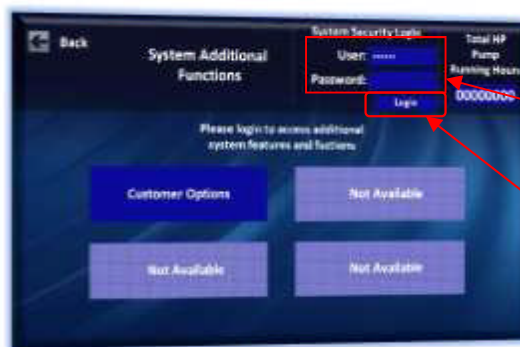

Enter user
credential
information
here

Press here
when finished



Press Here

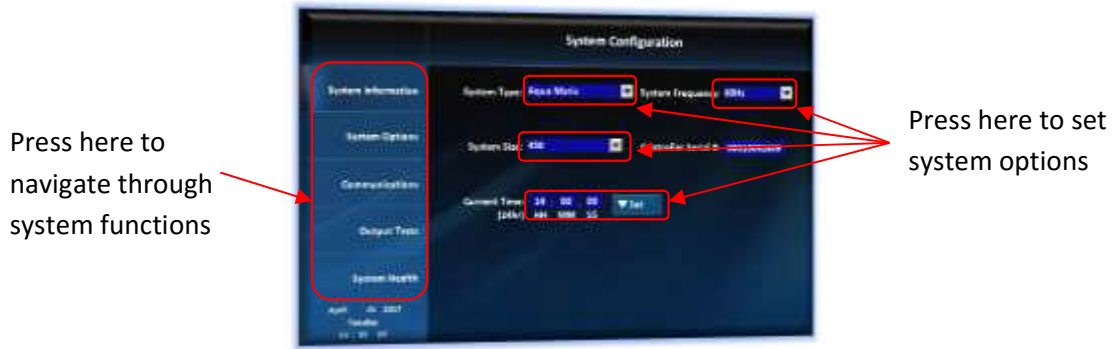

7. Press 'System Option' tab.

8. Select option applicable to your system.

System Tank Level Control	ON	OFF
System UV Sterilizer	ON	OFF
System Fresh Water Flush	ON	OFF
System Emergency Stop	ON	OFF



9. Press 'Communications' tab

10. Select options applicable to your system

Communications Status	ON	OFF
Communications Protocol	STD NMEA 2000	SRC
Communications Port	NMEA2000	Remote



11. Press system 'Output Tests' tab

CAUTION: This page is meant to test individual function test of components power and motor rotation prior to running the system. **SINCE SYSTEM IS NOT PRIMED WITH WATER DO NOT TRY TO RUN SYSTEM COMPONENT FOR LONG PERIODS OR DAMAGE WILL ACCURE.**



12. Press each tab to test Power and/or motor rotation

- Auxiliary Pump (On, Off)
- Booster Pump (On, Off)
- High Pressure Pump (On, Off)
- Product Valve (On, Off)
- Fresh Water Flush Valve (On, Off)
- UV Sterilizer (On, Off)
- Jog BPR Clockwise (Only available on Aquamatic Models)
- Jog BPR Counter Clockwise (Only available on Aquamatic Models)

13. Press System Health Tab

Note: This tab will show a complete overview of the current system health along with any external sensors connected. A 'Fault!!' indicator will appear if a problem is detected. High speed flow meters cannot be tested automatically, but the output values of these sensors can be viewed here and should display a value when pumps are operated.

The 'System Health' screen displayed by the controller is shown below:



Press here to save

14. Press Save & Exit

Your system is now configured.

Display Settings

The Aquamatic, Aquamatic XL and AquaWhisper desalination system controller also allows you to configure your desired display settings. These settings include language, unit display and screen brightness. To update any of these settings, please follow the procedures outlined below:

1. Press Anywhere on the Main Splash screen to begin.
2. Press the display setting icon shown below.
3. Press language to set desired language.

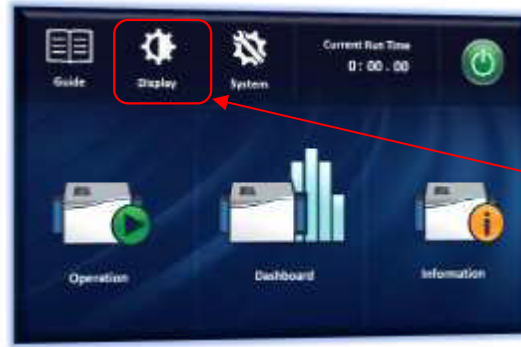

Press here



4. Press Units to set desired Units.

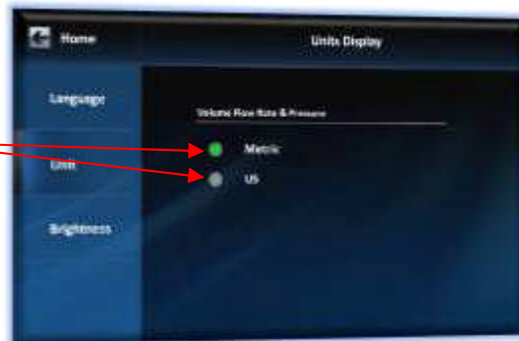

Press here

5. Press Brightness to set desired brightness level.

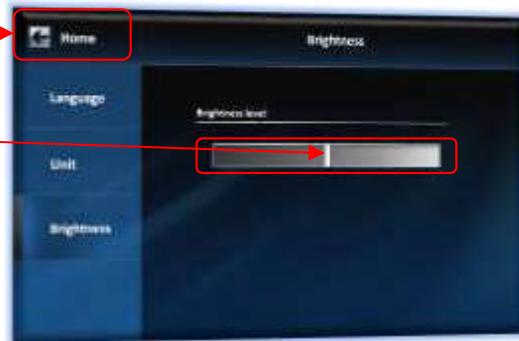

Press here

Press here
and slide left
or right

To return to the 'Main Menu' screen simply press on the 'Home' button, as shown above.

Setting System Clock

1. Press system settings icon.
2. Press Clock.

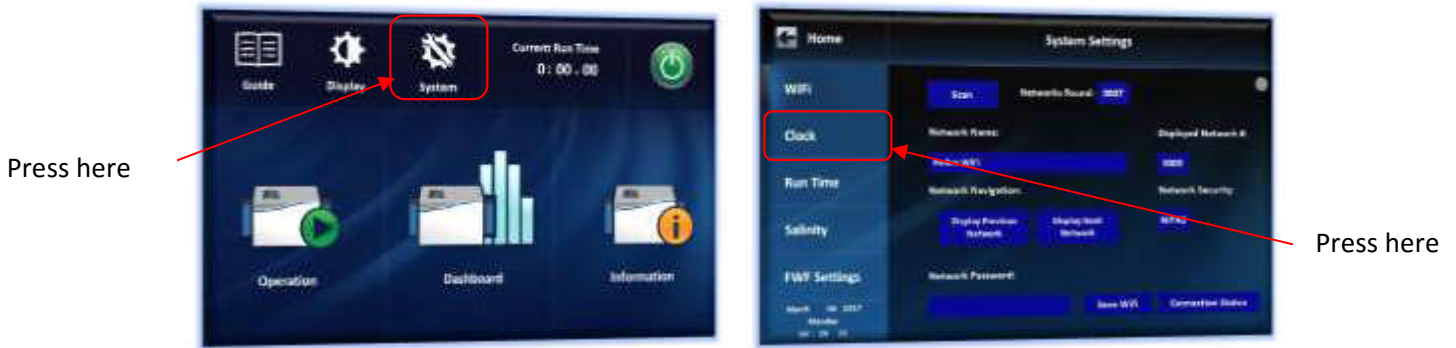

3. Choose your time format.
4. Press on Set Time enter in the correct time.
5. Press Set for 2 seconds to set time.

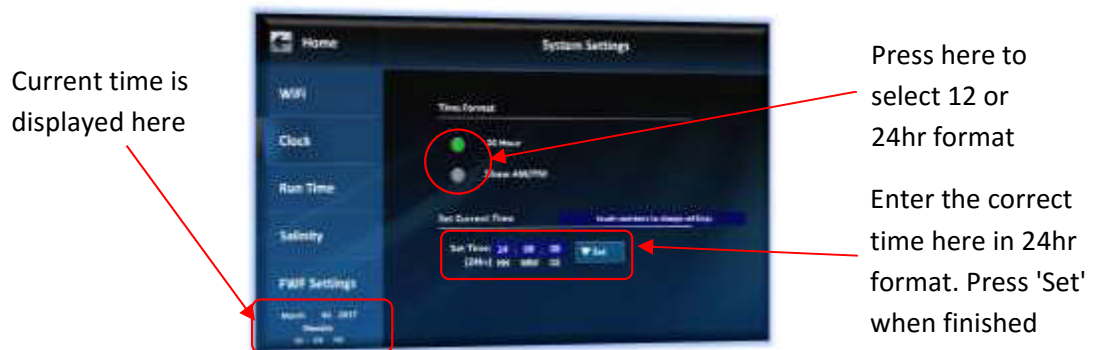

6. Press home to return.

Setting System Run Timers

1. Press system settings icon.
2. Press Run Time.

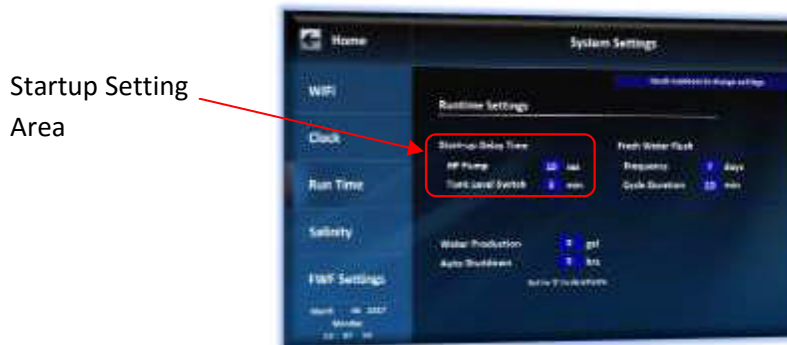

3. Press HP Pump Delay to change default setting for the HP pump time delay.

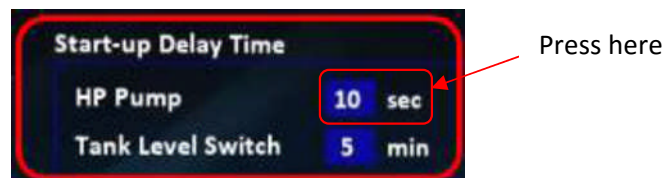

HP Pump Delay Time

This delay timer controls the startup delay applied to the high-pressure pump during system activation. The default delay time is 10 seconds, but if your application has the booster pump located some distance away from the main unit, a longer delay may be required to allow the feed water to reach the high-pressure pump. The time value delay range is from 5 seconds to 99 seconds.

4. Press Tank Level Switch to change default setting tank level switch

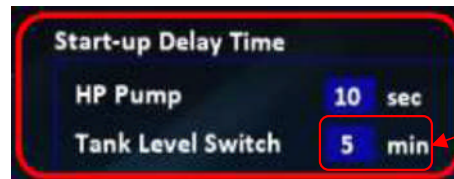

Press here

Tank Level Switch Delay Time

This delay timer controls the delay period applied to the state change of the production tank level switches. As the tank begins to fill with fresh water and with movement of the vessel, the water level within the tank will oscillate. This oscillation will cause constant activation and de-activation of the product tank level switches when the tank level is near their detection point, this programmable delay period is designed to accommodate for these oscillations, so false triggering of these level switches is avoided. The time value delay range is from 5 minutes to 99 minutes.

5. Press Water Production to change default setting to the desired amount before system shutdown. A value of zero '0' will de-activate this feature.



Auto Production
Setting Area

Water Production

This controls the amount of water produced by the water maker. Once the produced water equals the amount programmed, the water maker will shut down. When the user re-starts the water maker, it will run until the produced amount of water equals the value stated. Production range is from 1 gallon to 4000 gallons.

6. Press Auto Shutdown to change default setting to the desired time. A value of zero '0' will deactivate this feature.

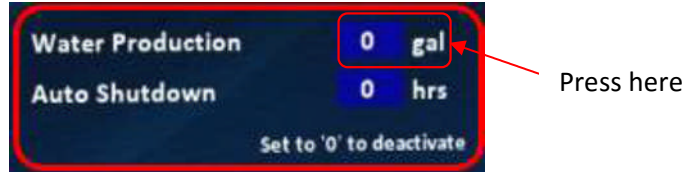

Auto Shutdown Operation

This controls the amount of time the water maker will operate. Once the operational time reaches the desired time, the water maker will shut down. When the user re-starts the water maker, it will run until the operational time stated. The time value range is from 1 hour to 48 hours.

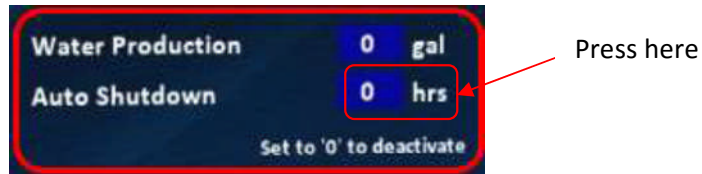

Fresh Water Flush

This controls the sleep time between system fresh water flush cycles and the duration of the fresh water flush.



Fresh Water Flush
Setting Area

7. Press Fresh Water Flush Frequency to change the default number of days between fresh water flushing.



Press here

8. Press Fresh Water Flush Cycle Duration to change the default time for fresh water flushing.



Press here

9. Press home to return.

Setting System Salinity

The Aquamatic, Aquamatic XL and AquaWhisper desalination system controller allows you to configure your desired production water quality using two methods. The primary method used is by the simple movement left or right of the salinity bar or entering a value.

1. Press system settings icon.
2. Press Salinity tab.



3. Move slider bar left or right to adjust salinity or enter desired value in required Product Quality.



The Salinity value range is 150PPM to 999PPM. Once the value is entered, the slider position, and the current setting value will update appropriately.

4. Press home to return.

Setting Fresh Water Flush

The Aquamatic, Aquamatic XL and AquaWhisper desalination system controller allows you to configure your desired fresh water flush program settings in two areas. The first area is in 'Runtime Settings', as discussed previously. However, the same setting can also be adjusted in the dedicated 'FWF Settings' tab, this tab also gives information about the current FWF system status, including the number of days until the next flushing cycle will take place.

5. Press system settings icon.
6. Press FWF Settings.

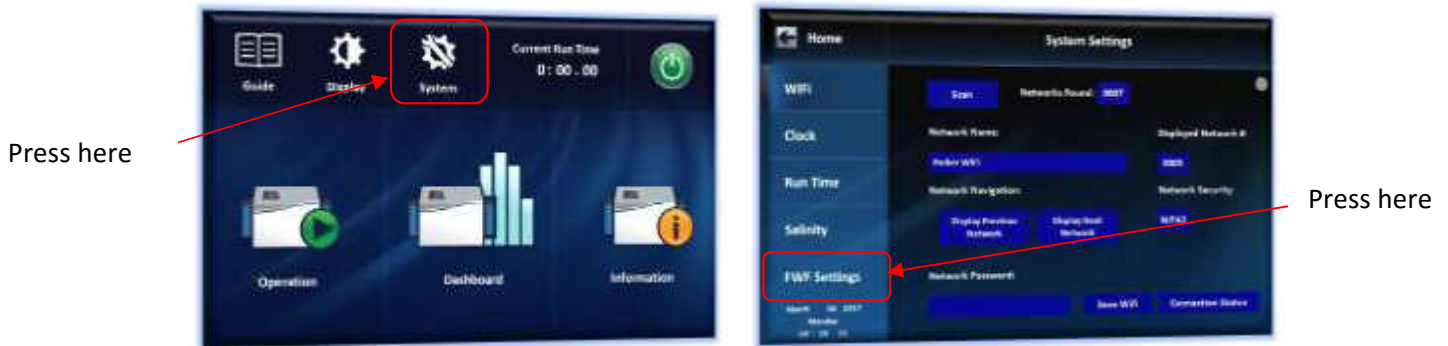

Fresh Water Flush Frequency

This controls the sleep time between system fresh water flush cycles. Immediately after a system shutdown, the fresh water flush program activates for a set duration. This flushing is done to remove sea water from system components, and replace it with fresh water. However, it is vital this fresh water be replaced every so often to ensure no biological growth can occur. The default cycle time is 7 days, meaning each 7 days the fresh water flush program will repeat. Programmable cycle times range from a minimum of 1 day to 15 days.

7. Press Fresh Water Flush Frequency to change the default number of days between fresh water

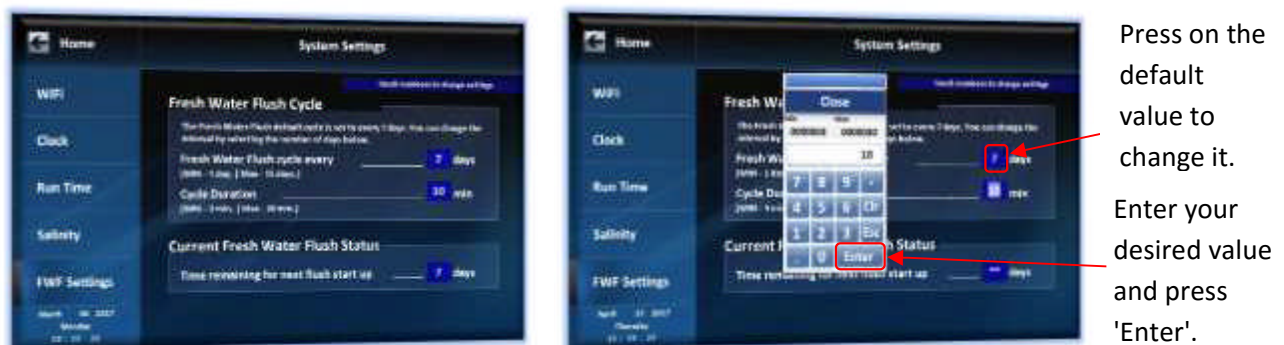

Fresh Water Flush Cycle Duration

This sets the fresh water flushing time. In most applications, a fresh water flushing time of 10 minutes is adequate to displace all sea water from the system. However, this cycle duration can be changed if desired. The Fresh Water Flush duration range is from 3 minutes to 30 minutes.

8. Press Fresh Water Flush Cycle Duration to change the default time for fresh water flushing.



Press on the default value to change it.

Enter your desired value and press 'Enter'.

Current Fresh Water Flush Status

NOTE: This display variable indicates the number of days remaining until the next fresh water flush cycle begins. If '**' is displayed, no fresh water flush cycles are scheduled

9. Press home to return.

Manual System Check

1. Ensure that the manual bypass lever on the 3-Way Product Water Diversion Valve is positioned outward (away from the coil body).
2. Open any auxiliary valve within the incoming Feed Line, Outgoing Brine Discharge Line and Outgoing Product Water Line.



Caution: If an auxiliary valve is installed within these lines and is closed during System start and/or operation, it will damage the System. The resulting damage is the liability of the Operator and is not covered by the Sea Recovery Corporation warranty.

3. Position Rinse-Clean Inlet Valve to normal operation towards the Sea Strainer.
4. Position Rinse-Clean Outlet Valve to normal operation towards the Thru Hull Discharge Fitting.
5. Check all filter housings to ensure that they contain the proper filter element.
 - a) *Sea Strainer*: Check for monel screen.
 - b) *Plankton Filter (if installed)*: Check for monel fine-mesh screen filter element.
 - c) *Multi Media Filter (if installed)*: Check for media (#20 silica sand).
 - d) *Dual Pre-filter or Commercial Pre-filter*: Check for pleated cartridge filter elements.
 - e) *Oil/water Separator*: Check for Oil/Water Separator filter element.
 - f) *RO Membrane Element(s)*: Check for Sea Recovery Serial Number and date on the label that is attached to each pressure vessel.
 - g) *Charcoal Filter*: Check for charcoal filter element.
 - h) *pH Neutralizer*: Check for pH Neutralizer cartridge.
 - i) *Fresh Water Flush Carbon Filter*: Check for Carbon element.
6. Perform function tests on electric components. Prior to assuming that an electrical component is broken or non-functional, perform a function test to determine if it is operable. Function tests should be performed manually for the following components, as part of the commissioning procedures:
 - Booster Pump Electric Motor
 - High Pressure Pump Electric Motor
 - Diversion Valve Energize Solenoid

-
- Fresh Water Flush Valve Energize Solenoid
 - Back Pressure Regulator Electric Motor Actuator
 - UV Sterilizer Ballast and Lamp
- a) Perform a rotational check on the electric motor. Ask an assistant to view the fan section of the Booster Pump Motor and High Pressure Pump Motor, while you “Jog” the electric motors. Rotation is clockwise when viewing the back of the electric motor (fan) and counter-clockwise when viewing the front of the pump.
 - b) Check the function of the following and correct any abnormalities:
 - *Diversion Valve*: 3-Way Product Diversion Valve Solenoid will energize momentarily. The valve should click when repositioning.
 - *FWF Valve*: Fresh Water Flush Solenoid Valve will actuate to the Fresh Water Flush position. Pressing the switch a second time will cause the Fresh Water Flush Solenoid Valve to revert to the Normal Feed position. The valve should click when repositioning.
 - *BPR In*: Back Pressure Regulator Motor Actuator will rotate clockwise momentarily. The motor actuator will not rotate in if the valve is less than one turn open.
 - *BPR Out*: Back Pressure Regulator Motor Actuator will rotate counter-clockwise momentarily. The motor actuator will not rotate out if the valve is greater than eight (8) turns open.
 - *UV Sterilizer*: UV Sterilizer will flicker. Check for illumination from the UV Sterilizer viewport.
7. Prime the System. To save time and make the initial System start easier, fill the feed water lines and each component in the Pre-filtration section with either feed water or fresh water. This will prime the feed water section, including the Booster Pump, so that it will be able to pick up and continue delivering feed water.

Multi Media Filter Backwash and Rinse

If the System is equipped with a Multi Media Filter, then it must be back-washed and rinsed to remove contaminants. Please refer to the figure on the next page for valve positioning.

1. Open the Inlet Sea Cock Valve.
2. Position the Rinse Clean Inlet Valve to the normal operating position towards the Sea Strainer.
3. Position the Rinse Clean Outlet Valve to the normal operating position towards the Multi Media Filter / Brine Discharge Thru-Hull Fitting.
4. Position the Multi Media Filter valves to backwash.
5. Set the controller into the Manual mode of operation, and operate only the Booster Pump.
6. After 10 minutes of back washing, stop the Booster Pump.
7. Position the Multi Media Filter valves to rinse.
8. In the Manual mode of operation, operate only the Booster Pump.
9. After five (5) minutes of rinsing, stop the Booster Pump.
10. Position the Multi Media Filter valves to Normal Operation.

VALVE POSITIONING OF THE MULTI MEDIA FILTER DURING 4 SEPARATE MODES OF OPERATION

PSI Differential with Clean Media:
 5 psi @ 4.2 gp m
 4 psi @ 3.5 gp m
 3 psi @ 2.5 gp m

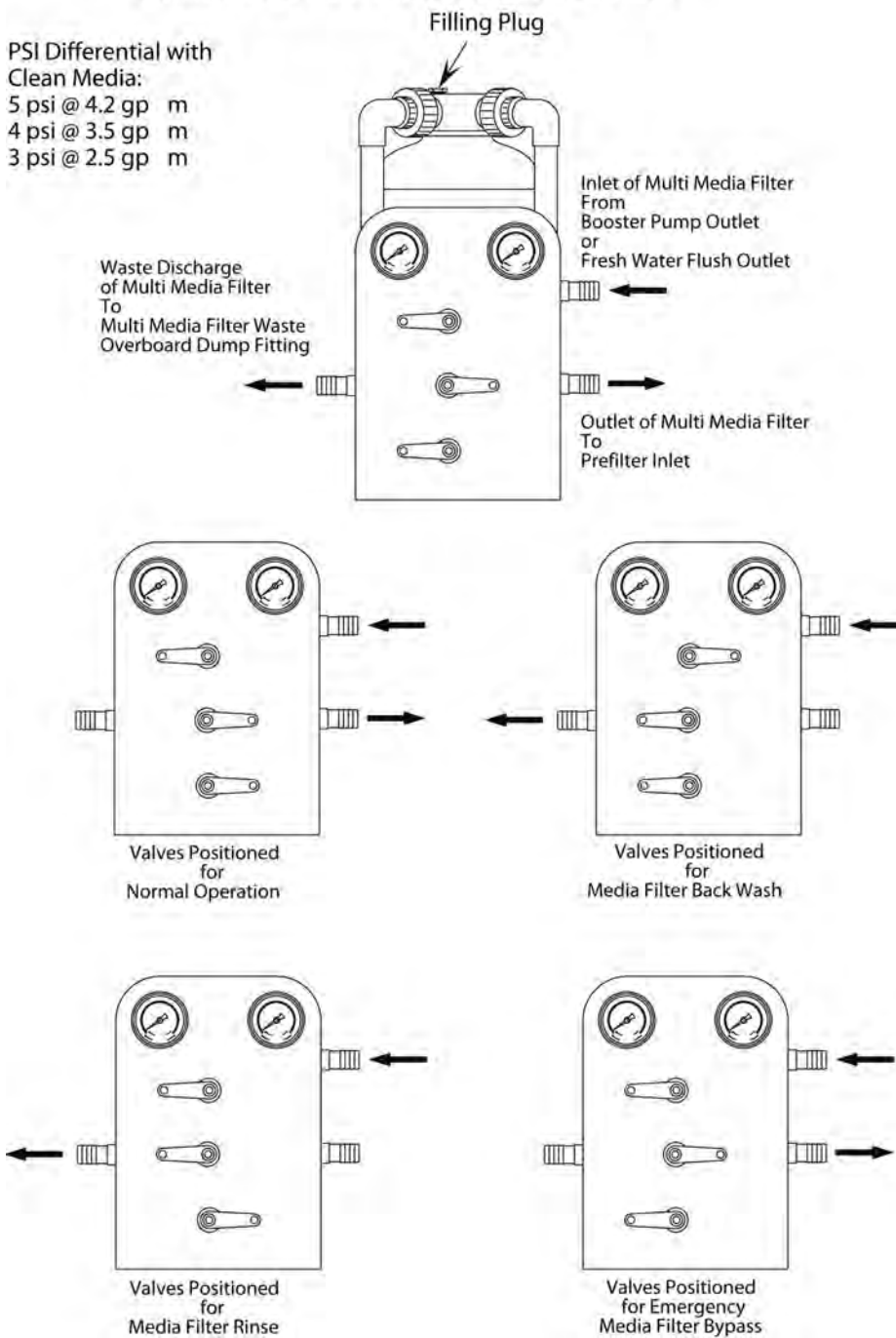

Chapter 6

General Operation

Important Notes

Please read the following operation notes carefully before turning on your System.

New Systems

A new System may take up to 30 minutes to purge the RO Membrane Element of the storage chemical and produce potable water. Although the system is producing "Product Water" after the storage chemical has been purged, the Product Water may not be potable (i.e., drinkable) for up to 30 minutes. The salinity of the Product Water diminishes gradually, until it reaches the factory setting. When the Product Water is potable, it will be diverted by the 3-way Product Water Diversion Valve to the **Potable** position and into the Post Filtration components, then onward to the ship's Storage Tank. At this point, the UV Sterilizer (if installed) will illuminate.

Freezing Temperature Warning

Caution: The System must be protected from freezing if it will be exposed to temperatures below 32°F (0°C). Freezing temperatures will cause extensive damage to the System as the water expands during the freezing process. Resulting damage to the System caused by freezing temperatures is the liability of the Operator.

Caution: DO NOT subject the System to temperatures below 32°F (0°C), unless the System has been rinsed with a solution of Product Water with 20% food-grade Glycerin (Propylene-Glycol).

RO Membrane Element Warning

Caution: Never store the RO Membrane Element or Membrane/Vessel Assembly in direct sunlight. Never expose the RO Membrane Element or Membrane/Vessel Assembly to storage temperatures above 120°F (50°C) or below 32°F (0°C). High temperatures may cause irreversible damage and up to 40% production loss in the RO Membrane Element. Freezing temperatures cause mechanical System damage, as well as irreversible damage to the RO Membrane Element.

Caution: The RO Membrane Element must remain wet at all times. Never allow the RO Membrane Element to dry out, as drying out may cause up to 40% production loss, as well as irreversible damage. Some, but not all, production may be restored by saturating the RO Membrane Element in Product Water for several days, and then operating the System by feeding Product Water into the System for a continuous 48-hour period.

Caution: Never expose the RO Membrane Element to chemicals other than those supplied by Sea Recovery Corporation. Use caution when operating the system in harbors that may be polluted with chemicals, oil or fuel, as these chemicals may damage the RO Membrane Element beyond repair.

Caution: Protect the RO Membrane Element from biological fouling, as it may cause significant production loss. Some, but not all, production may be restored after cleaning. The System must be protected from biological fouling if it will not be operated over a period of two (2) weeks or more.

Important: Third-party chemicals will destroy the RO Membrane Element! Only use Sea Recovery Corporation-supplied chemicals. **Never use third-party chemicals**, as they are incompatible with various System materials and will dissolve the co-polymer parts. Damage to the System or its components as a result of using third-party chemicals is not covered by the Sea Recovery Corporation Warranty.

Fresh Water Flush Warning

There must be sufficient Fresh Water in the Potable Water Storage Tank. In order to provide the required water flow to the System during the Fresh Water Flush cycle, the ship's fresh-water pressure system must deliver a minimum of 1 U.S. Gallons (3.8 Liters) per minute at minimum 25 PSI and maximum 60 PSI (minimum 172 kPa and maximum 414 kPa).

- If the Minimum of 1 U.S. Gallons (3.8 Liters) per minute at minimum 25 PSI (minimum 172 kPa) is not achieved, then the System may not fully flush the System with enough fresh water to displace the Feed Water (i.e., sea water).
- If the Maximum 60 PSI (maximum 414 kPa) is exceeded, then the System will shut down and revert to a *fault* mode due to excess pressure. In this event, the Owner or Installer must install a Pressure Reduction Valve from the ship's Pressurized Fresh Water Line prior to the inlet of the System Fresh Water Flush Charcoal Filter Inlet.

System Storage

If the System is not equipped with the Automatic Fresh Water Flush option or it will not be operated for an extended period of time (i.e., three months or longer), then you must perform a manual fresh water flush. Please refer to the topic [System Short- and Long-Term Storage](#) on page 54.

Powering the System ON

1. Switch the Electrical Power Source or ship's circuit breaker to System **ON**.

Note: Operating Screens *will not* include the Automatic Fresh Water Flush components if the Fresh Water Flush Option was not installed (i.e., the control logic has not been updated to include the Fresh Water Flush Option).

2. After the control logic has initiated, the default screen will appear indicating that the System is ready to start.



Automatic Mode

 **Note:** Auto Mode is highly recommended for Operators and Owners.

1. From the default screen, touch the **START** button.

 **Note:** All System readings, pressures, flows and salinity will be displayed on the Touch Screen.

2. Although the System is producing product water, it may not be potable (i.e. drinkable) for up to 30 minutes. The salinity of the Product Water diminishes gradually, until it reaches the preset setting. When the Product Water is Potable, the UV Sterilizer energizes. The Potable Water is then diverted by the 3-way Product Water Diversion Valve to the potable position and into the Post Filtration components, onward to the Storage Tank.
3. If an abnormality develops, touch the **STOP** button and correct the problem.
4. During operation, check for the following conditions:
 - a) Constant feed water flow.
 - b) Consistent system pressure.
 - c) Leaks in the System.
 - d) Abnormal noises or other occurrences.
5. Record the System's initial performance readings. Use the [New System Initial Readings Form](#) on page 98.

Manual Mode

 **Important:** Manual Mode is intended for SRC technicians for set up and configuration purposes.

 **Note:** The Remote Touch Screen will be blocked during operation in the Manual Mode.

Caution: When the System is operated in the **MANUAL** mode, safety features will still be controlled by the System Logic; however **AUTOMATED** features will not be controlled by the System Logic and must be controlled by the Operator.

1. From the default screen, touch the **SETUP** tab.
2. On the next screen, touch the **Acceptable Salinity Level** button.
3. On the Salinity Level screen, adjust the salinity to desired level (188 to 370 PPM), then touch the **SETUP** button.
4. On the next screen, touch the **Manual Mode** button.
5. On the next screen, touch the Booster Pump **START** button then wait 5 seconds for booster pump to stabilize.
6. Touch the HP Pump **START** button.
7. Slowly increase the high pressure level meter until the System product flow rate is reached.
 - **PRODUCT SALINITY (RED)** means that the dissolved solids in the Product Water have not yet decreased to an acceptable level. Although the system is producing "Product Water," the Product Water may not be potable (i.e. drinkable) for up to 30 minutes. The salinity of the Product Water diminishes gradually, until it reaches an acceptable level or lower.
 - **PRODUCT SALINITY (GREEN)** means that the dissolved solids in the Product Water have reached the acceptable level and the Diversion Valve can be activated.
8. Activate the Diversion Valve. Touch the Diversion Valve button, which will cause the optional UV Sterilizer to energize, as well as the 3-Way Product Water Diversion Valve to energize. "Potable" (good water) will then be diverted into Post Filtration and onward to the Ship's Storage Tank.



Note: All System readings, pressures, flows and salinity will be displayed on the Main Touch Screen.



Important: If an abnormality develops, touch the **STOP** button in the top right corner of the screen. A warning screen will display. Correct the problem and then repeat Steps 1-8.

9. During operation, check for the following conditions:
 - a) Constant feed water flow.
 - b) Consistent system pressure.
 - c) Leaks in the System.
 - d) Abnormal noises or other occurrences.
10. Record the System's performance readings in the daily log. Please utilize the form for [Daily System Readings](#) on page 99.

Startup Sequence

Before starting the System in Auto Mode, prepare yourself for the sequence of events below. After the System has been started, the following process will occur:

1. Booster Pump electric motor will start.
2. Low Pressure Transducers will signal the System Control Logic, which will look for adequate feed water pressure from the Booster Pump.
3. After 20 seconds, the High Pressure Pump electric motor will start and a screen will indicate that it has started.
4. Feed Water Flow Meter will signal the System Control Logic, which will look for adequate feed water flow through the System.
5. After 20 seconds, the Automatic Back Pressure Regulator will rotate clockwise to build up operating pressure.
6. Product Water Flow Meter will register product water flow, as operating pressure exceeds the osmotic pressure of the feed water. Product Water Flow will take priority to inform the control logic to increase or decrease operating pressure in order to maintain the product water flow specification.
7. Salinity Probe will register the quality of the Product Water. When the salinity of the Product Water lowers to the set point, the UV Sterilizer will energize (if installed).
8. The 3-Way Product Water Diversion Valve will energize, sending the Product Water to the Post-Filtration section. This may take up to 30 minutes, as the Product Water flushes storage chemical from the System.
9. Feed Pressure, Feed Flow, Operating Pressure, Brine Flow, Product Flow and Product Salinity are all being monitored and the values of these readings cause the System Control Logic to perform various tasks to maintain proper functioning of the System.
10. The System may be manually stopped, or it may be programmed to stop at a given volume of Product Water production.
11. When the System is signaled to perform a non-emergency stop, the Automatic Back Pressure Regulator Valve will rotate counter-clockwise to lower operating pressure.
12. The 3-Way Product Water Diversion Valve will revert to non-potable water.
13. The UV Sterilizer will stop.



If the STOP is touched the System will immediately stop all functions. When the System is signaled to perform a non-emergency stop:

 - a) The Automatic Back Pressure Regulator Valve will rotate counter clockwise to lower operating pressure.
 - b) The 3-Way Product Water Diversion Valve will revert to unpotable water.
 - c) The UV Sterilizer will stop.
 - d) The High Pressure Pump will stop.
 - e) The Booster Pump will stop.
 - f) If the System does not include the Automatic Fresh Water Flush option this ends the stop sequence.

- g) If the System includes the Automatic Fresh Water Flush the Automatic Fresh Water Flush Valve will energize to Fresh Water. After 7 to 15 minutes the Fresh Water Flush Valve will de-energize and the Stop sequence is complete.
14. The System will go to a Fresh Water Flush Stand-by mode and count down the days until the next automatic Fresh Water Flush Cycle. The Fresh Water Flush Cycle will automatically initiate until canceled or power is disconnected from the System.

Powering the System OFF

Automatic Mode

-  **Note:** Auto Mode is highly recommended for Operators and Owners.
-  **Important:** If the Automatic Fresh Water Flush option is installed and if the System Control Logic has been set to perform Automatic Fresh Water Flushing, then the Touch Pad will show the Operator when the automatic cycle is being performed.

1. From the default screen, touch the **STOP** button.

If the Automatic Fresh Water Flush option is not installed or selected in the System Control Logic, pressing the **STOP** button will place the System into the Automatic Shut Down mode. The pressure will reduce; the HP Pump will stop; the Booster Pump will stop; the 3-Way Product Water Diversion Solenoid Valve will de-energize; and the UV Sterilizer will de-energize (if installed).

2. The Automatic Fresh Water Flush cycle starts.

The Fresh Water Flush Solenoid Valve will energize for seven (7) to 15 minutes and then will flush the System with fresh water. After the Fresh Water Flush cycle has completed, the Fresh Water Flush Solenoid Valve will de-energize, and the System will go into **STANDBY** mode. At the end of a preset number of days, the Fresh Water Flush cycle will repeat.

-  **Note:** The automatic Fresh Water Flush cycle will stop if the power has been interrupted or if the **CANCEL** button has been touched.

Manual Mode

-  **Important:** Manual Mode is intended for SRC technicians for set up and configuration purposes.

1. From the Manual Mode screen, reduce the pressure to 0 psi using the "-" (*negative*) button.
2. Touch the Diversion Valve button to de-activate.
3. Touch the HP Pump **STOP** button.
4. Touch the Booster Pump **STOP** button.

-  **Note:** The Automated Fresh Water Flush Cycle will not be performed until the System is operated in the Automatic Mode.

The Automated Fresh Water Flush will NOT activate automatically because operation during the Manual Mode deactivates all Automated features. In order to perform a Fresh Water rinse, follow the directions in the topic [Short-term Shutdown Procedure](#) on page 55.

System Short- and Long-Term Storage

The dark, moist interior of the RO Membrane Element is a breeding ground for micro-organisms. System operation, alone, does not protect the RO Membrane Element from production loss due to biological fouling. Prior to short-term shutdowns, the System must be rinsed (and winterized if the System is / will be exposed to freezing temperatures). Prior to long-term shutdowns, the System must be chemically treated (and potentially winterized), in addition to being rinsed.

Once-through Configuration

1. Configure the Suction line for a Once Through Configuration (as shown in the figure on the next page). Disconnect the outlet line from the Sea Strainer and place it in the Rinse/Clean Bucket or Container. Otherwise, if the system is equipped with the optional Rinse Clean Inlet Valve, then position this valve to draw from the Rinse/Clean Bucket or Container.
2. Configure the Brine Discharge line for a Once Through Configuration (as shown in the figure on the next page). Connect the Brine Discharge Line from the system to the Thru-Hull over board discharge fitting, normal connection for normal operation. Otherwise, if the system is equipped with the optional Rinse Clean Outlet Valve, then position this valve to discharge through the Thru-Hull fitting, normal connection for normal operation.

Closed-loop Configuration

1. Configure the Suction line for a Closed Loop Configuration (as shown in the figure on the next page). Disconnect the outlet line from the Sea Strainer and place it in the Rinse/Clean Bucket or Container. Otherwise, if the system is equipped with the optional Rinse Clean Inlet Valve, then position this valve to draw from the Rinse/Clean Bucket or Container.
2. Configure the Brine Discharge line for a Closed Loop Configuration (as shown in the figure on the next page). Disconnect the Brine Discharge Line from the Thru-Hull over board discharge fitting and place it in the Rinse/Clean Bucket or Container. Otherwise, if the system is equipped with the optional Rinse Clean Inlet Valve, then position this valve to draw from the Rinse/Clean Bucket or Container.

SYSTEM MAIN CONTROLLER UPDATE AS OF 10/30/2017

Manual Operation

The Aquamatic, Aquamatic XL and AquaWhisper DX desalination system controller provides two possible methods of operation; these are manual mode and automatic mode. In manual mode, the controller requires that the operator activate the relative pumps by pressing on the required pump operation icons. If the user attempts to operate a pump when it is determined by the control system as unsafe to do so, the controller will not allow such an action and will in some cases raise a warning message.

NOTE: Before attempting manual start up, it is important to check that all system feed and brine valves are in the open position.

1. Press anywhere on the main splash screen to begin.
2. Press Operations icon shown below.
3. Press Manual Mode icon shown below.



NOTE: The Manual control screen displayed may vary from the examples shown below, depending on the product model in use. To provide complete details, this manual will review the procedures needed for operation of an Aquamatic, or Aquamatic XL system. Hence, this description will contain automatic pressure regulation operation information that is not needed when operating an AquaWhisper DX system.



4. Press Booster Pump icon.

NOTE: If starting system for the first time, allow time for the system to be primed before starting HP Pump.

NOTE: To stop the system at any time use the Manual Stop at the top right corner.



Booster Pump Off



Booster Pump On



NOTE: A warning message may pop up in the lower left hand corner of the screen giving details of the failure. The operator must correct this situation before being allowed to continue.



NOTE: If the booster pump has been activated, and no conditions prohibiting operation of the high-pressure pump exist, the controller will make the 'Start HP Pump' button available, as shown below:

5. **Press HP Pump icon.**



HP Pump Control
(Available but not active)

6. Adjust pressure to 800 PSI (55 BAR) by pressing and holding the increase arrow icon.

NOTE: If you have an Aqua Whisper DX use the regulator knob for this step.

NOTE: Automatic Pressure Control: (only on Aquamatic & Aquamatic XL systems)



NOTE: Once system pressures have exceeded the minimum allowable, the 'Decrease' button will also be made available.



NOTE: Once the maximum pressure available, the 'Increase' button will no longer be made available.

System Pressure Control
(Only 'Decrease' available)



NOTE: If the UV Sterilizer is not installed skip next step.

7. Press UV Sterilizer icon.

NOTE: It may take several minutes for UV Sterilizer to become active. The system must sense good potable water for the icon to activate.



UV System Control
(Shown if installed)
(Available but not active)

8. Press the Product Valve Icon to activate the Diversion valve.

NOTE: Once the UV system has completed its warm up cycle or once the controller has detected potable water, the control system will make the 'Start|Stop Product Valve' button available.



NOTE: You may view the operation data on the right of the screen below or schematic view.



Automatic Operation

Automatic startup operation allows for virtually hands free startup of the Aquamatic, Aquamatic XL or AquaWhisper DX system, and all associated equipment. This automatic startup operation can also be carried out remotely via the system remote control display (if installed).

NOTE: Before attempting automatic start up, it is important to check that all system feed and reject valves are in the correct position.

1. Press anywhere on the main splash screen to begin.
2. Press Operations icon shown below.
3. Press the Start or Auto Start/Stop icon.

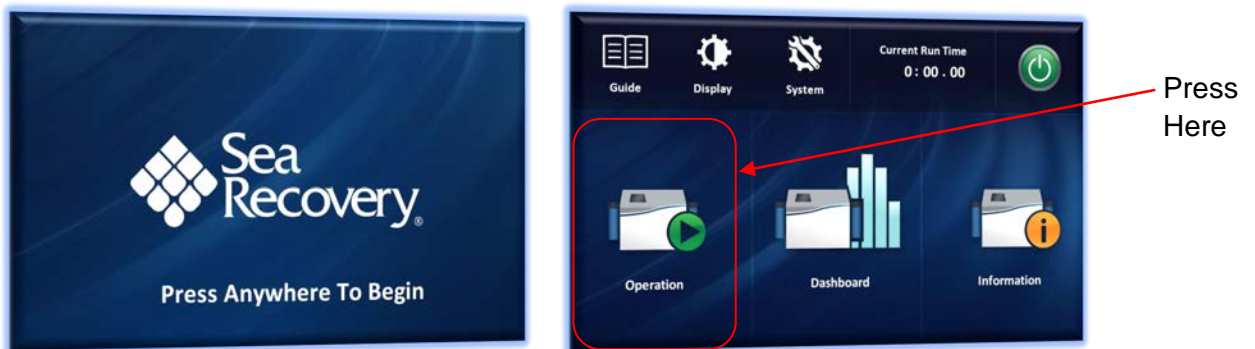

NOTE: If the control system is unable to successfully calibrate the pressure control regulator, an error message will be displayed, and automatic startup will be aborted. An example of this error message is shown below:



NOTE: There will be a system priming delay of approximately 25 second once boost pump has turned on to when the HP Pump turns on.

4. For Aqua Whisper DX system increase pressure to 950 PSI (65 BAR) by turning the regulator valve.

NOTE: For Aquamatic & Aquamatic XL systems, after a further 60 seconds the system will activate the automatic pressure regulator and start increasing system pressure until the desired product water production rate has been achieved or until max pressure allowable (925 PSI - 65 BAR). If Max pressure is achieved, you will get a warning message. This will most likely happen when you are in low temperature, high salinity feed water, or when your membranes need cleaning or changing. The Aquamatic and Aquamatic XL system will continue to operate in this high-pressure state and will divert all potable water produced into the ships potable water storage tank.



NOTE: If the control system detects a dangerous condition, or a failure of a critical sensor during automatic operation. The system will bring the Aquamatic, Aquamatic XL and AquaWhisper DX system to a rapid stop, and display the detected failure in an alarm screen, as shown below:

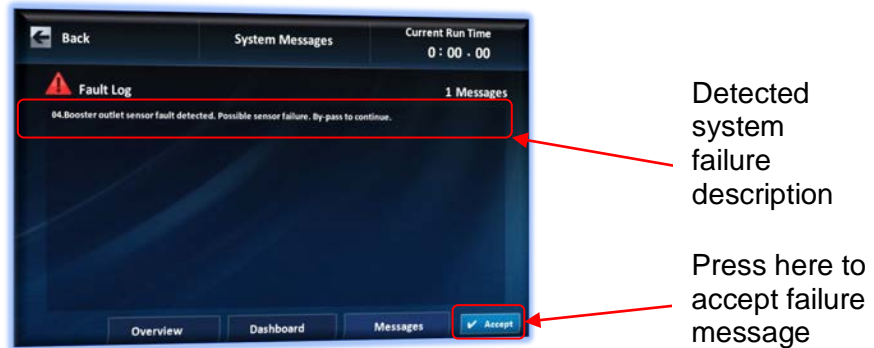

5. To Stop the system from running press the Stop icon or the Auto Start/Stop icon.



The system will start shutting down in the sequence below

- The product diversion valve will be de-activated
- The UV system will be set into shutdown mode (if installed)
- The High-Pressure pump will be stopped
- The Back-Pressure control regulator assembly will be re-initialized to prepare for correct fresh water flush operation (Aquamatic & Aquamatic XL systems only)
- For Aquamatic & Aquamatic XL systems, after successful re-initialization of the Back-pressure control regulator the system will begin a 10 second countdown, once this countdown has elapsed the booster pump will be de-activated.
- For Aqua Whisper DX system, after successful deactivation of the high pressure pump, the system will begin a 10 second countdown, once this countdown has elapsed the booster pump will be de-activated.

Now automatic shutdown operations have completed. If the system is not re-started within 30 seconds, the system will begin a fresh water flushing cycle.

Accessing Your Various Display Screens

1. Press Dashboard icon.



All available system data is shown in the users chosen display unit.

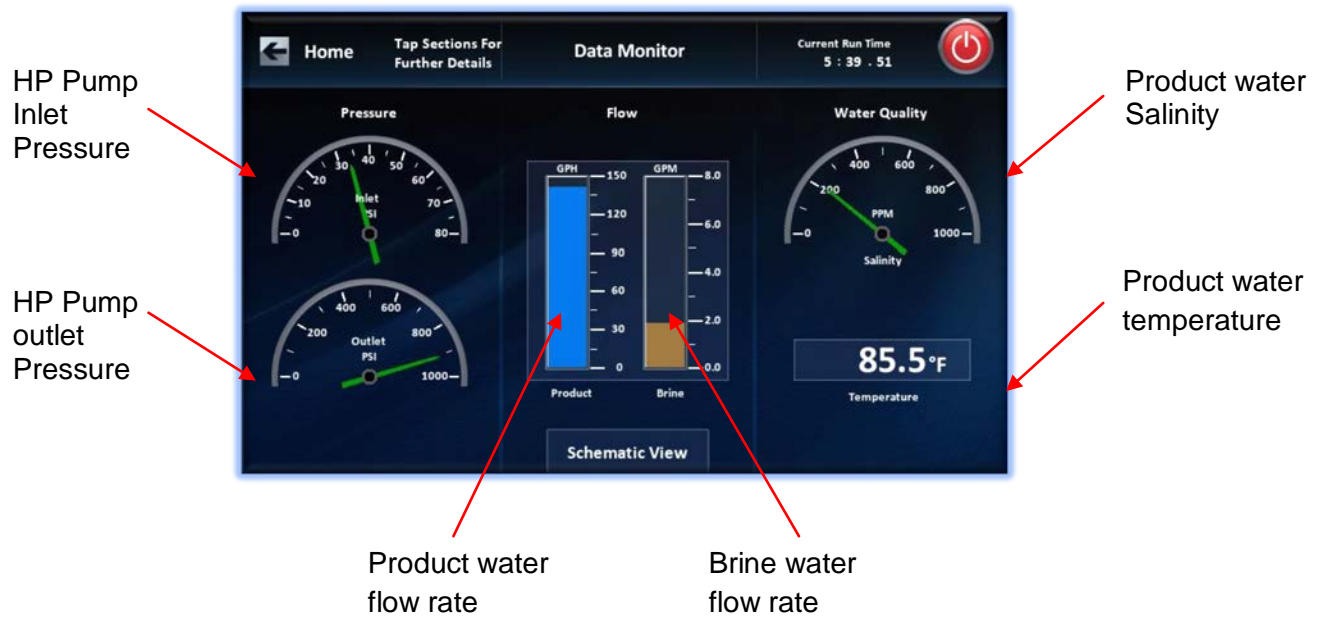

2. Press Tap Selection Tab for Further Details.

- To get to any of the 3 screens (Pressure, Flow, or Water Quality) press the area in the boxes below.



- Pressing the arrow button in the top left hand corner of the water quality screen two times will return you to the main menu screen as shown below:



Accessing System Fault & Warning Log

1. Press Information Icon

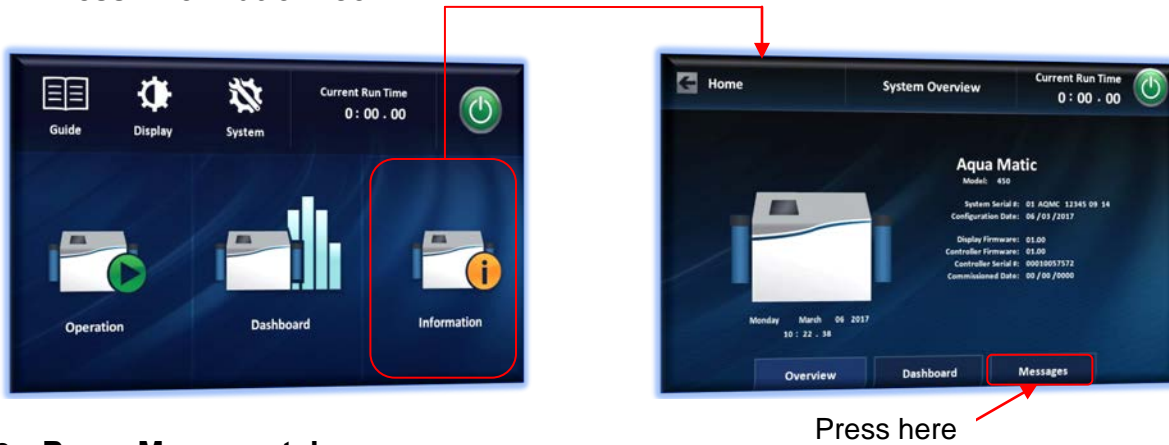

2. Press Message tab.

3. Press the 'Fault Log' or 'Warning Log' area, as shown on the below.

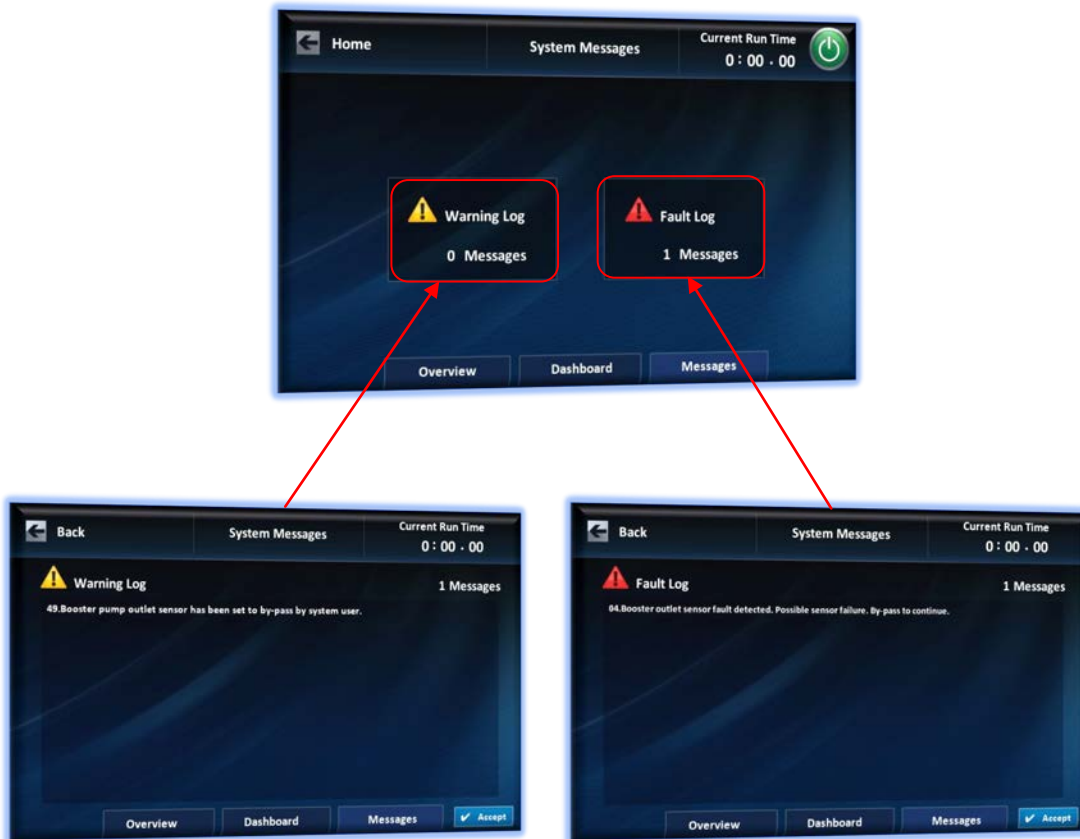

4. Pressing the arrow button in the top left hand corner on the screen to exit

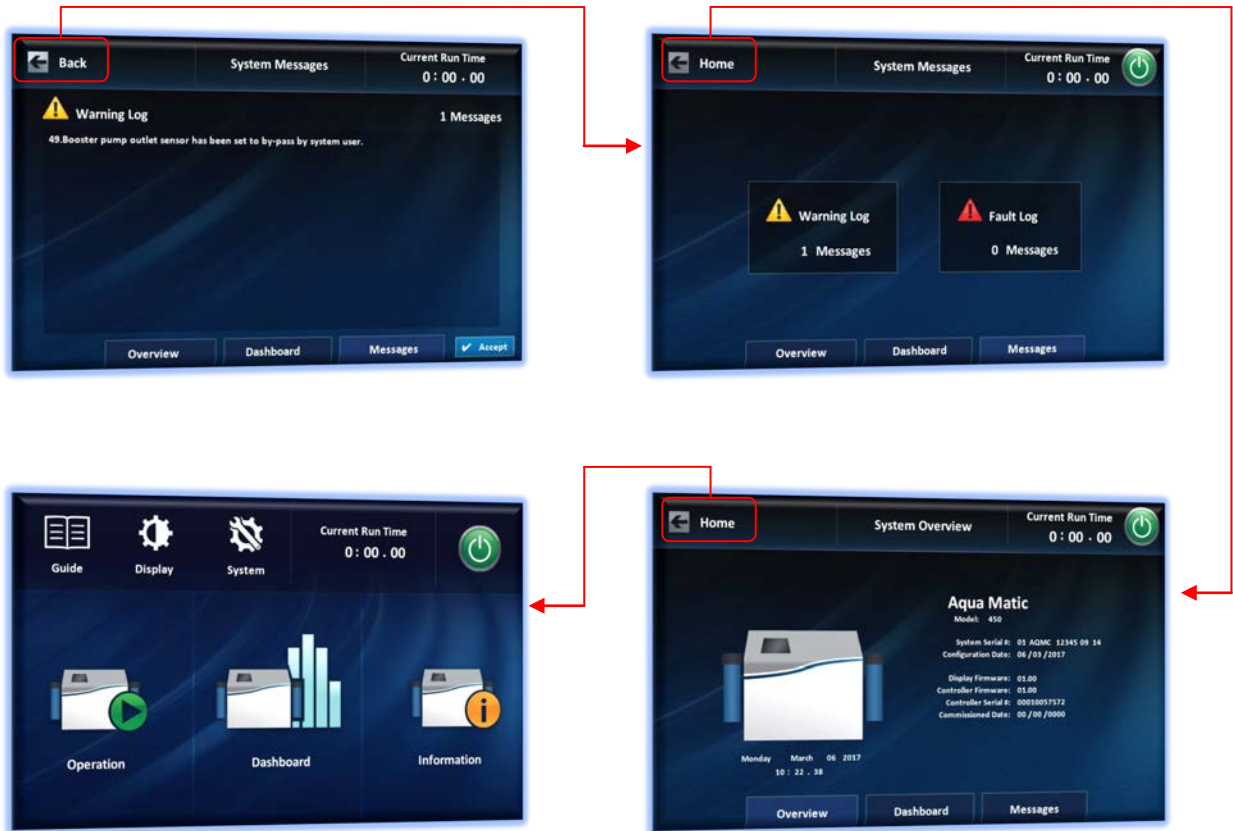

Accessing High Pressure Pump Hour Meter

The Aquamatic, Aquamatic XL, and AquaWhisper DX desalination system controller constantly records your high pressure pumps operational hours.

1. To access the high-pressure pump hours display press on the 'Current Run Time' area, available on most screens.

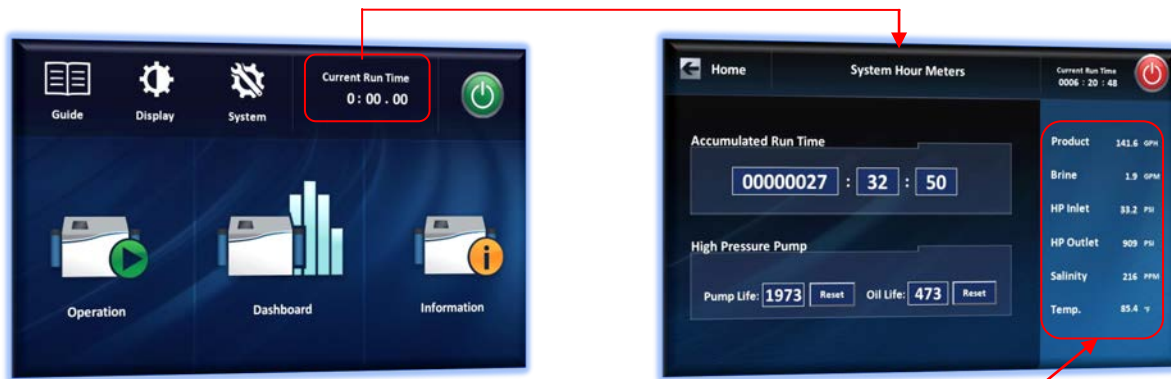

System live data

2. The high-pressure pump hours display screen also contains additional information

Total operation hours of unit

Estimated hours remaining before pump service required

Estimated hours remaining before pump oil change required

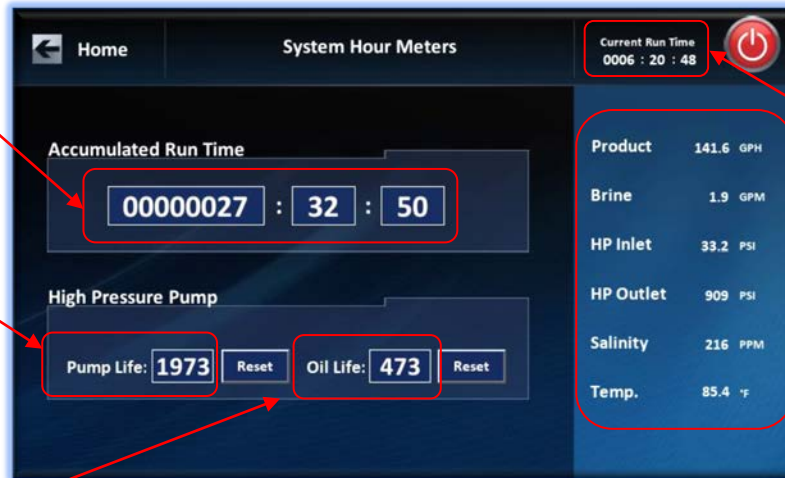

Current operation timer

System live

The high-pressure pump hour display provides two maintenance life timers, these being pump life, and oil life. These timers monitor high pressure pump operation. The Pre-programmed meter has reached zero '0', a warning message will be displayed each time the high-pressure pump is activated. The life timer display will simply show '****', indicating that the life meters have expired. Once the maintenance has been performed, the user may reset these life meters by pressing the appropriate 'Reset' button.

NOTE: It is not possible to reset a life meter until its measured life value has reached zero.

3. Pressing the arrow button in the top left hand corner to exit back to main page.



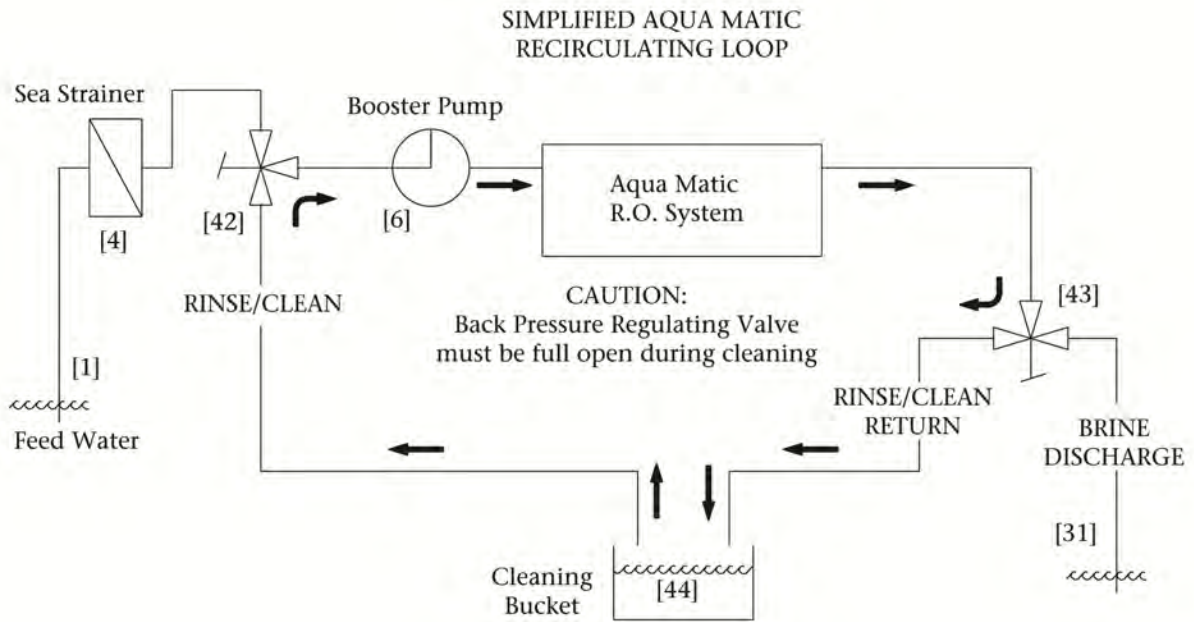
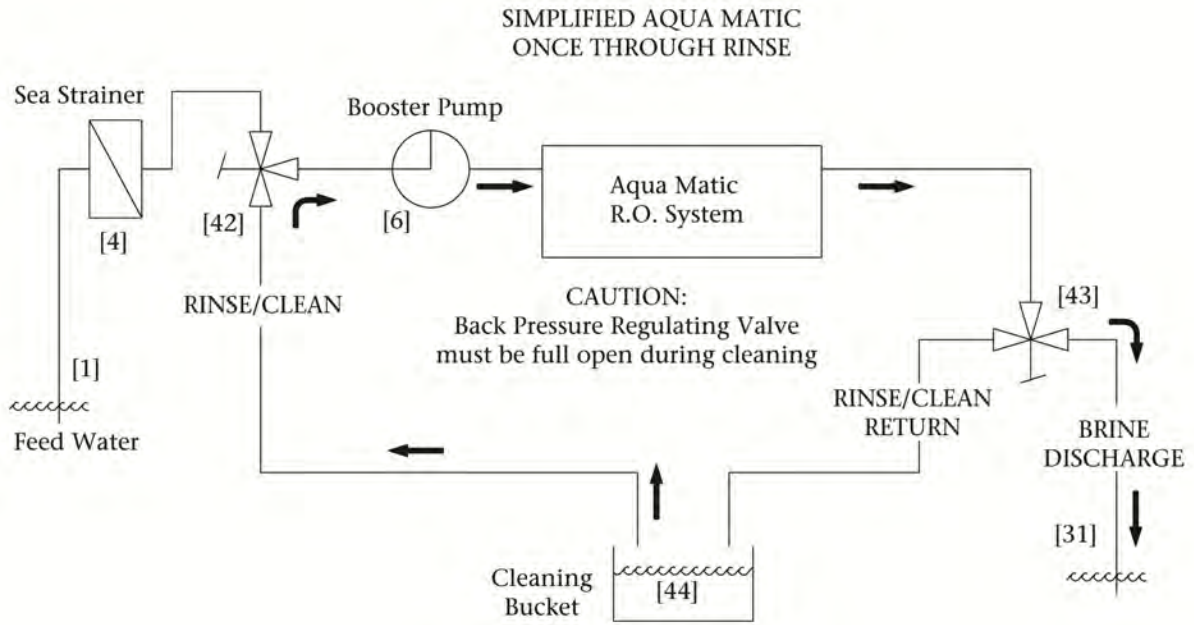

Short-term Shutdown Procedure

Short-term shutdown is defined as a period of up to four (4) weeks, in which the System is not being used. To effectively protect the System and RO Membrane Element(s) during the short-term shutdown, you must perform a Fresh Water Rinse (i.e., a rinse with fresh Product Water from the System). The Fresh Water Rinse prolongs System and RO Membrane Element life by minimizing electrolysis and arresting biological growth. If your System

is not equipped with the Automatic Fresh Water Flush option, or if it needs to be winterized against freezing temperatures, follow the procedure in this topic. The procedure provides instructions for displacing the System's Feed Water with Fresh Product Water (i.e., potable water), adds propylene glycol (if winterizing), and protects the System during shutdown.

Caution: If the System is, or will be, exposed to freezing temperatures, **do not** activate the Automatic Fresh Water Flush; instead, perform the Manual Fresh Water Rinse procedure described in this topic.

 **Note:** 10 gallons (38 liters) of Fresh Product Water is required for the Fresh Water Rinse. Two (2) gallons (7.5 liters) of food-grade glycerin (propylene glycol) is required for winterizing.

1. Close the Inlet Sea Cock Valve.
2. Fill a container with 10 gallons (38 liters) of Fresh Product Water.

 **Important:** If the System is, or will be, exposed to freezing temperatures, add two (2) gallons (7.5 liters) of food-grade glycerin (propylene glycol) to the container of Fresh Product Water. Propylene-Glycol prevents water within the System from freezing.

3. Configure the System for a Once-Through Rinse, as described within the topic [Once-through Configuration](#) on page 54.
4. Operate the System in **Manual Mode**.

 **Note:** System operation will deplete the Fresh Product Water or Fresh Product Water / Propylene-Glycol mixture. You must **STOP** the System before depleting the water or water mixture.

5. Proceed to the topic [Long-term Shutdown Procedure](#) on page 56 if the System will be shut down for more than four (4) weeks.

Long-term Shutdown Procedure

Long-term (or prolonged) shutdown occurs when the System remains unused for over four (4) weeks. Before a long-term shutdown, the System must first be rinsed with Fresh Product Water, and then with Sea Recovery Corporation's *System and Membrane Element Storage Chemical (SRC SC)*. SRC SC inhibits bacterial growth, while maintaining the RO Membrane Element's high flux and salt rejection properties. If the System will be shut down for over four (4) weeks and **is not** equipped with the Automatic Fresh Water Flush accessory, or if it needs to be winterized against freezing temperatures, follow the procedure in this topic. The procedure provides instructions for displacing the System's Feed Water with Fresh Product Water (i.e., potable water), adds propylene glycol (if winterizing), and protects the System during shutdown. If the System **is** equipped with the Automatic Fresh Water Flush accessory, then it is not necessary to read this section, as long as the Automatic Fresh Water Flush cycle remains active, and the System is not exposed to freezing temperatures.

 **Important:** Third-party chemicals will destroy the RO Membrane Element! Only use Sea Recovery Corporation-supplied chemicals. **Never use third-party chemicals**, as they are incompatible with various System materials and will dissolve the co-polymer parts. Damage to the System or its components as a result of using third-party chemicals is not covered by the Sea Recovery Corporation Warranty.

Caution: If the System is, or will be, exposed to freezing temperatures, **do not** activate the Automatic Fresh Water Flush; instead, perform the Manual Fresh Water Rinse procedure described in this topic.

The following items are required in preparing the System for long-term shutdown:

- 20 gallons (75.7 liters) of Fresh Product Water.
- Sea Recovery Corporation's *System and Membrane Element Storage Chemical (SRC SC)*.
- **If winterizing:** Two (2) gallons (7.5 liters) of food-grade glycerin (propylene glycol).

1. Follow the procedures documented in the topic [Short-term Shutdown Procedure](#) on page 55.
2. Fill a container with 10 gallons (38 liters) of Fresh Product Water.
3. Add four (4) oz. of SRC SC to the container of Fresh Product Water.
4. Configure the System for a Recirculating Closed-Loop configuration as described in the topic [Closed-loop Configuration](#) on page 54.
5. Start the System in **MANUAL MODE**.
6. Operate the System in the Recirculating Closed-Loop configuration for 10 minutes. After 10 minutes, **STOP** the System.

Draining Component Water (for Winterizing)

If the System is, or will be, exposed to freezing temperatures, then components within the System's Post-Filtration section must be drained of all Product Water.

1. Drain the Charcoal Filter and replace the element.
 - a) Remove the Charcoal Filter bowl.
 - b) Remove the water from the bowl.
 - c) Replace the Charcoal Filter Element with a new Charcoal Filter Element.
 - d) Place the bowl back onto the lid.
2. Drain the pH Neutralizing Filter.
 - a) Remove the pH Neutralizing bowl.
 - b) Remove the water from the bowl.
 - c) Place the bowl and pH element back onto the lid.
3. Drain the UV Sterilizer.
 - a) Disconnect the Product Water Line from the UV Sterilizer Filter.
 - b) Drain the Product Water.
 - c) Turn the System's power **OFF**.
 - d) **Lock and Tag** the Power Breaker to ensure that the System isn't turned back **ON** (which will displace the Winterizing Mixture with Feed or Fresh Water).
 - e) Discard the Storage Chemical in an environmentally safe manner.

Cleaning the RO Membrane

Throughout its life cycle, the RO Membrane Element requires cleaning; the frequency of which depends on the amount of production and salt-rejection loss (from normal, day-to-day use). At the element's end of life (EOL), biological growth and salt accumulation make replacement necessary. To properly assess the RO Membrane Element's performance changes, Sea Recovery Corporation strongly recommends that you maintain a daily log of readings for comparison. When making performance comparisons, you must consider, and compensate for, the following variables:

- Feed Water Temp
- Feed Water Salinity
- System Operating Pressure

After compensating for the preceding variables, a 10% decline in productivity (measured in GPH Flow), and/or a 10% increase in salt passage, indicate that the RO Membrane Element may need to be cleaned.

 **Important:** If a dramatic drop in productivity is observed *after the System has been in storage*, it may indicate that the RO Membrane Element has dried out and/or fouling has occurred. In this case, attempt to operate the system for 48 (or more) continuous hours to saturate the RO Membrane Element's Product Water Channel. If a dramatic drop in productivity is observed *on a day-to-day basis*, it may indicate non-cleanable fouling

(e.g. suspended solids from silt, coral dust, iron (rust), river or inland waterway debris, other small solid matter, etc.). Sewage chemicals and petroleum products will cause irreparable damage to the RO Membrane Element.

About New Systems

 **Important:** Do not arbitrarily clean the RO Membrane Element in a **NEW** System, as it will not be fouled with any substance that is cleanable. Low productivity and/or high salinity indicate problem factors other than fouling.

Low productivity in a **NEW** System may indicate one (or more) of the following conditions: a blockage in the Product Water Line; the Feed Water temperature is too low; the operating pressure is too low; or that the RO Membrane Element has dried out, prior to use. A **NEW** System that yields low productivity should be operated for up to 48 hours continuously to clear and saturate the RO Membrane Element and Product Water Channel. Correlate and compensate for operating pressure, Feed Water temperature and feed water salinity (as charted in [Temperature and Pressure Effects](#) on page 13). If, after 48 continuous operating hours, the **NEW** System still yields low productivity, then please contact Sea Recovery Corporation. If a **NEW** System yields poor Product-Water quality (i.e., that which is high in salinity), it could be attributed to mechanical failure (e.g., broken or missing O-ring). In this case, poor Product-Water quality will be accompanied by high productivity at a low operating pressure.

Reverse Osmosis Water and Cleaning Requirements

Caution: Do not mix cleaning chemicals. Do not use different cleaning chemicals together at the same time. Mix the cleaning chemicals separately and utilize them separately.

 **Important:** Third-party chemicals will destroy the RO Membrane Element! Only use Sea Recovery Corporation-supplied chemicals. **Never use third-party chemicals**, as they are incompatible with various System materials and will dissolve the co-polymer parts. Damage to the System or its components as a result of using third-party chemicals is not covered by the Sea Recovery Corporation Warranty.

- The system must be rinsed with fresh water before and after any cleaning procedure.
- The process of rinsing and cleaning the RO Membrane Element with one (1) cleaning compound requires 30 gallons (113.5 liters) of fresh, non-chlorinated Product Water. If more than one cleaning is performed (using different cleaning compounds), then an additional 20 gallons (75.7 liters) is required per additional cleaning.
- Sea Recovery Corporation's Reverse Osmosis cleaning compounds are designed for moderate fouling scenarios. If your RO Membrane Element is excessively fouled and in-field cleaning is not successful, you may return it to Sea Recovery Corporation or to an authorized Service Dealer for professional chemical cleaning. If your RO Membrane Element requires professional cleaning, please contact Sea Recovery Corporation for a Return Authorization Number, price quote and return instructions. Professional cleaning is time intensive and complex; thus, in some cases, it will be more cost effective to replace a heavily fouled RO Membrane Element with a new element.
- SRC MCC-1, or Membrane Cleaning Compound "#1," is an alkaline cleaner designed to clean biological and slight oil fouling. Biological fouling is fairly common and occurs because the System is constantly exposed to seawater. If exposed to seawater while not in operation, the RO Membrane Element can still become fouled. To keep biological fouling at a minimum, rinse the System with fresh water when it is not in use.
- SRC MCC-2, or Membrane Cleaning Compound "#2," is an acid cleaner designed to clean calcium carbonate and other mineral deposits. Mineral fouling is a slow process that occurs while the System is in use.
- SRC MCC-3, or Membrane Cleaning Compound "#3," is used for iron fouling and *is not* included in the Membrane Cleaning Chemical kit. If your System's RO Membrane Element is fouled with rust from iron piping, then SRC CC-3 may be used for its effective removal. Note that a rust-fouled RO Membrane Element may not be recoverable, as rust not only fouls the element, but also damages the element's surface.

Cleaning Procedure

The following table displays the Product Water (in U.S. Gallons) that is required to clean the RO Membrane Element:

Chemical	Rinse water required	Cleaning water required	Cleaning water required	Total water required
MCC-1	10	10	10	30
MCC-2		10	10	20
MCC-3		10	10	20

1. Close the Inlet Sea Cock Valve.
2. If installed, put the Multi Media Filter Valves in the "Multi Media Filter Bypass" position during cleaning. See figure in the topic [Multi Media Filter Backwash and Rinse](#) on page 46 for Multi Media Filter Bypass Valve positioning.
3. Replace the Pre-filtration Cartridge with a new Sea Recovery Corporation-supplied Pre-filtration Element.
4. Fill a 10-gallon (37.8 liters) container with clean, potable water.
5. Configure the System for a Once-Through Rinse, as described within the topic [Once-through Configuration](#) on page 54.
6. Start the System in **MANUAL MODE**.



Note: System operation will deplete the fresh water in the container. Before depleting the water entirely, touch the **STOP** button.

7. Once again, fill the container with 10 gallons (37.8 liters) of clean, potable water.
8. Add 1.5 lbs. (0.68 kg) of Sea Recovery Membrane Cleaning Compound MCC 1, MCC 2 or MCC 3 to the water container and thoroughly mix the solution until the cleaning compound has dissolved.
9. Configure the system for a Recirculating Closed Loop configuration.
10. Start the System in **MANUAL MODE** and operate it in the Recirculating Closed-Loop configuration for 60 minutes. After 60 minutes **STOP** the System.
11. Configure the system for a Once-Through Rinse.
12. Start the System in **MANUAL MODE** to discharge the cleaning chemical to waste.



Note: System operation will deplete the fresh water in the container. Before depleting the water entirely, touch the **STOP** button.

13. For the last time, fill the container with 10 gallons (37.8 liters) of clean, potable water.
14. Configure the system for a Recirculating Closed-Loop configuration.
15. Start the System in **MANUAL MODE** and operate it in the Recirculating Closed-Loop configuration for 10 minutes. After 10 minutes **STOP** the System.
16. Configure the system for a Once-Through Rinse.
17. Start the System in **MANUAL MODE** to discharge the rinse water to waste.



Note: System operation will deplete the fresh water in the container. Before depleting the water entirely, touch the **STOP** button.

The system is now ready for additional cleaning, use or storage. If further cleaning is necessary, repeat Steps 4 to 17 for each additional cleaning.

18. If the System will be expose to freezing temperatures, please review [Draining Component Water \(for Winterizing\)](#) on page 57.

Chapter 7

Maintenance and Repair

Prerequisites

Ensure that you—as the Installer, Operator or both—read and understand the prerequisites, warnings and important notes within this topic.

System Updates

From time to time, Sea Recovery Corporation may make programming changes to the control logic. Other physical production changes may also be made, and are tracked by Sea Recovery Corporation through the System's serial number.

✔ **Remember:** Troubleshooting and repair method results can vary depending on the information that is displayed on the **SYSTEM INFORMATION** screen.

- **SERIAL NUMBER:** Helps Sea Recovery Corporation to determine the latest physical version and configuration of your System, ensuring that you are provided with correct part information.
- **TYPE:** Tells Sea Recovery Corporation the production capacity of your System, which provides a bench mark in diagnosing product water flow and pressure concerns.
- **VERSION:** Allows Sea Recovery Corporation to determine the specific sequential operation of the System based on the programming control logic version.



Depending on the issue, Sea Recovery Corporation may also request the System's operating Voltage, cycles and phase.

Installer Minimum Qualifications

The System's Installer must have technical expertise in the following areas:

- Electrical, Electronic, Electric Motors and Circuits
- Electromechanical and Mechanical Systems
- Hydraulic and Liquid Pressure and Flow Systems
- Piping and Plumbing Systems

-
- Water Suction and Pressure Lines
 - Thru-Hull Fitting below and above water level

Do not attempt maintenance and repair if you are not proficient in the aforementioned fields of expertise.

System Safety Check

Danger: Do not perform installation, maintenance or troubleshooting procedures until you have verified the following conditions:

- The System's Feed Water Sea Cock Valve is closed.
- The System's main electrical disconnect switch is **OFF, LOCKED** and **TAGGED**.

Chemical Precautions

Danger: The RO Membrane Element is susceptible to chemical attack. Take extreme caution in handling and storing! Do not expose your Aqua Matic RO Desalination System to feed water containing chemicals not approved in writing by Sea Recovery Corporation.

Do not connect a water line to your Aqua Matic RO Desalination System that may contain any of the following chemicals:

- Hydrogen peroxide chloramines-T
- Chlorine dioxide chlorine
- Bromine phenolic disinfectants
- Chloramines N-chloroisocyanurates
- Hypochlorite iodine
- Bromide petroleum products



Important: The use of non-authorized and/or the *misuse* of authorized chemicals will void your Sea Recovery Corporation warranty! For example, **DO NOT** connect the Aqua Matic RO Desalination System's inlet to your ship's potable water system if it contains chlorinated or brominated water. These chemicals destroy the copolymer components and the oxidants will damage the RO Membrane Element. In this situation, you can use the *optional* **Sea Recovery Fresh Water Flush Accessory** to remove the chlorine and bromine from your ship's potable water system before connecting the Aqua Matic RO Desalination System.

Note on Component Cleaning

If detergents are used to clean the System's internal, wetted components, then you must ensure that the components are rinsed, wiped and dried thoroughly prior to reassembly. After all components have been reassembled, the System's Product Water can be used to remove Feed-Water residue from the components' exterior surfaces.

Warnings

Danger: ELECTRICAL SHOCK HAZARD The Aqua Matic RO Desalination System installation procedures expose the installer to high voltage and potential electrical hazards. Technicians should only attempt installation if (1) they are qualified electricians and (2) surrounding conditions are safe.



Important: Third-party chemicals will destroy the RO Membrane Element! Only use Sea Recovery Corporation-supplied chemicals. **Never use third-party chemicals**, as they are incompatible with various System materials and will dissolve the co-polymer parts. Damage to the System or its components as a result of using third-party chemicals is not covered by the Sea Recovery Corporation Warranty.

Weekly Quick Check

To proactively address System problems, Sea Recovery Corporation strongly recommends performing the checks below on a weekly basis.

1. Inspect fasteners for tightness (including brackets, screws, nuts and bolts).

 **Note:** Pay special attention to the High Pressure Pump and Electric Motor, as they are exposed to heavy vibrations.

2. Clean salt water or salt deposits from the System with a damp cloth.
3. Check for water leaks throughout the System and supporting water lines.
4. Check tubing and high-pressure hoses for wear and abrasion.

 **Note:** Hoses must not come into contact with heated or abrasive surfaces.

Operator Maintenance Intervals

Maintenance frequency varies from case-to-case and depends on the following factors:

- How often the System is used
- Intake water condition
- How long the System has been exposed to water
- Total running time
- The manner in which the system is installed or operated

Due to the variable factors listed above, the recommended maintenance timetable is based on *estimated* time intervals and may differ based on your individual System. Although the maintenance timetable is based on factual data compiled from actual Aqua Matic RO Desalination System installations, this schedule should be adjusted to your individual System.

 **Important:** Components, spares, and consumables utilized within the System are specific to Sea Recovery Corporation specifications and are not commercially available from other sources. Other Components utilized within the System are modified by Sea Recovery Corporation for the specific purpose of compatibility and are not commercially available from other sources. Many of these special components may appear similar to Sea Recovery components; however, *extensive* and *expensive* damage to the Aqua Matic RO Desalination System will occur if incompatible components are used. Please refer to the third-party parts warning below for additional information.

Third-Party Parts Warning

The major documented cause of failures and problems are from the use of third-party, non-Sea Recovery parts; improper installation; and improper operation. **Do not use parts, components from any source other than Sea Recovery!** The use of third-party, non-Sea Recovery parts is *strongly discouraged* and will result in the following consequences:

- The use of third-party, non-Sea Recovery components, spares and assemblies will damage the Sea Recovery System and/or specific components within the System.
- The use of third-party, non-Sea Recovery components, spares and assemblies will void any and all warranty of the System and/or void the affected component within the System.

 **Important:** Sea Recovery Corporation maintains inventory for immediate shipment and our Service Dealers throughout the world maintain stock of Sea Recovery parts. Always insist on Sea Recovery supplied parts in order to avoid failures, eliminate problems, and maintain your warranty.

Component Maintenance and Repair

Inlet Thru Hull Fitting

- *To be supplied by the System's Owner.*
- Keep the Inlet Thru Hull Fitting free and clear of debris and marine growth. A clogged Inlet Thru Hull Fitting results in a low feed pressure condition, which causes System shut off.
- The Inlet Thru Hull Fitting must be clear of blockages in order to allow the System to draw 4.5 U.S. Gallons (17 Liters) of Feed Water per minute. Blockages at the Inlet Thru Hull Fitting will cause low pressure and low flow problems.
- The Installer must utilize a forward-facing scoop, so that the system receives positive water flow when the ship is moving. The fitting must be installed on the ship's hull, in a position that provides a continuous, air-free supply of Feed Water.

Caution: If the Sea Recovery System is connected to a Sea Chest or Stand Up Pipe, do not plumb the Sea Recovery System feed line to the top of these feed water arrangements. If plumbed to the bottom, the System will intake air and experience continual shut down. The System's resulting failure will thus be attributed to improper installation, will be the liability of the installer, and is not covered by the Sea Recovery Corporation warranty. Ensure that the System is plumbed to the bottom of the feed water arrangements to ensure a continual, air-free supply of Feed Water.

Sea Cock Valve

- *To be supplied by the System's Owner.*
- Packing and connections must be tight and properly sealed.
- Clean the valve cavity of debris, or replace the seal, seat, or entire valve, as required.
- When System is in operation, this section is under vacuum conditions. Loose fittings or a worn seal will allow air to enter the System, thereby causing continual shut down due to low Feed Water pressure.

Inlet Connection

Replace if damaged.

Sea Strainer

Keep the mesh screen free and clear of debris. When mesh screen is clogged, a low-pressure condition results and causes System shut off. When System is in operation, this section is under vacuum conditions. If Sea Strainer's bowl is loose or the O-Ring seal is worn/improperly seated, the System will continually shut down due to low Feed Water pressure.

Electric Motor and Booster Pump Assembly





Note: Centrifugal, counter-clockwise rotation, as viewed from pump's volute (front) end.

Electric Motor

When troubleshooting electric-motor failure, check power, wiring, connections, contacts and the control circuit. A failed electric motor requires repair or replacement. If failure is due to an external source (not the motor itself), attempt to correct the cause to prevent future failure, and/or the need for replacement/repair. Electric motor failure may be due to the following:

Winding failure	Generally caused by power that is outside the voltage range requirements of the system.
Capacitor failure	Generally caused by low power feeding the motor and/or low cycles from the power source. Also caused by rapidly repeating the motor start and stop.

 **Attention:** The Booster Pump *must* rotate in the *counter-clockwise direction*. Rotating the Booster Pump in the clockwise direction will cause extensive damage.

 **Attention:** When switching from 3-Phase Generator power to 3-Phase Shore power, *always* check phases prior to operating the System. Otherwise, reverse rotation (and extensive damage) may occur when the power is out-of-phase.

Electric-Motor Problems (caused by Booster Pump or Electric Motor) and Solutions:

1. The Single Phase (115 or 230VAC) Electric Motor “hums,” pulls starting current (locked rotor) amperage, does not rotate, and trips the supply power circuit breaker when attempting to operate the System. The Single Phase Electric Motor is a capacitor-start motor. If the motor was repeatedly and rapidly started with low voltage or a drop in voltage occurred while starting, the capacitor will short out. Without the aid of a working capacitor, the motor will “hum,” pull starting current (locked rotor) amperage, not rotate, and trip the supply power circuit breaker when attempting to operate the System.
 - a. Check wiring size and connections to, from, and in between the Power Supply and the Electric Motor. Correct wire size or any loose wires.
 - b. Check the capacitor on the motor, and replace it if it has shorted out.
 - c. Measure motor voltage during attempt to start it. If voltage drops more than 10%, locate and correct the reason.
 - d. Check the motor starter relay (contactor) for “burnt” contacts.
2. The 3-Phase (230/380/460 VAC) Electric Motor “hums,” pulls starting current (locked rotor) amperage, does not rotate, and trips the supply power circuit breaker when attempting to operate the System. The 3-Phase Electric Motor requires all three power lines (all three phases) to operate, otherwise it will revert to “single phase” (resulting in extensive damage to the motor’s internal windings). Note that low voltage will also cause the same symptom.
 - a. Same troubleshooting steps as that for the Single Phase (115 or 230VAC) Electric Motor, above.
3. The Electric Motor makes an unusual “grinding” sound when operated.
 - a. Check and replace the front and rear bearings, as necessary.
 - b. Check if the fan is rubbing against the fan guard.

Booster Pump

Replace ceramic seal approximately every 2000 hours, or at the sign of leakage.

Disassembly

Remove the four 3/8-16 bolts holding the volute to the motor bracket. To remove the impeller, remove the bearing cap on the motor to expose the screwdriver slot on the motor shaft. Hold the motor shaft with a large screwdriver and remove the impeller by grasping it and turning the impeller counter clockwise. Remove the seal. Two screwdrivers wedged into the seal at 180° apart serve as tools to wedge the seal out. The ceramic seat is removed by removing the end-bell gasket.

Reassembly

Clean the motor shaft and the bracket of any corrosion or salt deposits. Replace the end bell gasket and the tap seat portion into the bracket cavity. Use a new gasket. Place the ceramic seat into the cavity over the shaft. Make sure that the polished side is toward the end of the shaft. Tap into place evenly using a hollow piece of wood or plastic tool. If a metal tool is used to tap into place, protect the seat with cardboard or a clean cloth. Lubricate the shaft with water and soap or a light oil and slip the rotating portion of the seal over the shaft with the carbon element toward the ceramic. Slide it down onto the shaft as far as possible. Apply blue Loctite to the motor shaft threads. Hold the motor shaft and reinstall the impeller. Tighten the impeller by turning it clockwise until it is snug. Reinstall the volute. Tighten the bolts evenly. Thoroughly prime the pump.

Some Electric Motors supplied by Sea Recovery have permanently sealed and lubricated bearings. Others require lubrication from time to time. If your Electric Motor has grease jerks at each end of the motor (over the front and rear bearings), the bearings require lubrication every six months. Give three pumps of high temperature motor bearing lubricant into each grease jerk. Use a Polyurea Base Grease such as Chevron SRI (Polyurea Base) or Shell Dolium R (Polyurea Base). **DO NOT USE LITHIUM OR SILICONE BASE GREASE.**

T-Connector Pressure Pick-Up

Replace kinked hoses or tubes. Disconnect each end of the hose/tube and blow air through it to ensure that it is not blocked. Replace if damaged.

Pressure Transducers

Pressure Transducers are irreparable and cannot be calibrated. If inoperable, check connections at the transducer and printed circuit board to ensure that there is no visible corrosion, or loose connections.

Plankton Filter Element (Cleaning)

1. Unscrew the bowl counter-clockwise.
2. Remove the Plankton Filter Elements from the bowl.
3. Remove the O-Ring from the top of the bowl.
4. Clean the mesh screen filter elements with a bristle brush and water spray.
5. Wipe the O-Ring with a damp cloth.
6. Lightly lubricate the O-Ring.
7. Place the O-Ring back onto the bowl.
8. Insert the cleaned or new plankton filter elements into the bowls.
9. Screw the bowls on clockwise.
10. Hand tighten to seal the O-Ring. Do not use a wrench or other tool to tighten and do not over tighten. Over tightening transfers stress to the lid and bowl threads, causing the lid or bowl to fail (e.g. crack or break) and makes subsequent disassembly difficult.

Multi Media Filter Backwash

The Multi Media Filter contains fine gravel and #20 silica sand. This silica sand traps suspended solids larger than 20 micron. The top layer of the silica sand becomes packed with suspended solids and restricts flow through it. When the silica sand becomes packed with suspended solids (as indicated by a loss of pressure), it must then be back washed to waste. The back washing procedure fluffs the silica sand and dislodges the suspended solids from the sand base. During back washing, the suspended solids are discharged to waste through the Multi Media Filter Waste outlet. If replacing the media, the Multi Media Filter requires approximately 15 lbs. (7 kg) of small gravel (1/8 x 1/4 in. (3.27 x 6.35 mm), first on the bottom, then approximately 26 lbs. (12 kg) of #20 silica sand (on top of the small gravel).



Note: New gravel and sand contain contaminants. The Multi Media Filter must be back washed prior to use.

1. Open the Inlet Sea Cock Valve.
2. Position the Rinse Clean Inlet Valve (if installed) to the normal operating position towards the Sea Strainer.
3. Position the Rinse Clean Outlet Valve (if installed) to the normal operating position towards the Brine Discharge Thru-Hull Fitting.
4. Position the Multi Media Filter valves to Backwash.
5. In the Manual mode of operation, operate only the Booster Pump.
6. After 10 minutes of back washing, stop the Booster Pump.
7. Position the Multi Media Filter Valves to Rinse.
8. In the Manual mode of operation, operate only the Booster Pump.
9. After 5 minutes of rinsing, stop the Booster Pump.
10. Position the Multi Media Filter Valves to Normal Operation.

Commercial or Dual Pre-filter Element Replacement

The Commercial or Dual Pre-filter Pleated Cartridge Element may be cleaned with water spray once or twice. After cleaning, the expected life will be reduced in half. Attempts to clean the element more than twice will result in damage and failure. Change the element after the second cleaning. Clean or replace when blockage occurs (i.e., the pressure into the High Pressure Pump is equivalent to 10 PSI (69 kPa) or less. At slightly below 6 PSI (41 kPa), the System will turn off and display a fault screen.

Caution: Do not use third-party pre-filter elements; use only Sea Recovery Corporation pre-filter elements. Debris bypass through third-party elements will damage the High Pressure Pump and prematurely foul the RO Membrane Element. Use of third-party pre-filter elements voids any and all warranty on the High Pressure Pump and the RO Membrane Element.

Caution: Do not use “string wound” or “fiber” pre-filter elements. These elements are designed for the Photographic Film Developing industry. When used in sea water, they will plug rapidly.



Attention: *DO NOT ACCEPT THIRD-PARTY PRE-FILTER ELEMENTS FROM ANY MARINE DEALER. USE ONLY SEA RECOVERY SUPPLIED PRE-FILTER ELEMENTS.* The System's resulting failure, and/or damage to the System caused by third-party pre-filter elements, is attributed to improper maintenance and operation, is the liability of the operator and owner, and is not covered by the Sea Recovery Corporation warranty.

To replace the Commercial Pre-filter Element or Dual Pre-filter Element, follow the instructions below:

1. Unscrew the lid-locking ring or bowl counter-clockwise.
2. Remove and discard the used Pre-filter Pleated Cartridge Element from the housing or bowl.
3. In the case of the dual pre-filter element, remove the O-Ring from the top of the bowl.
4. Thoroughly clean the inside of the bowl. The High Pressure Pump is manufactured to a very tight tolerance spacing between moving parts. The pre-filter will catch debris and protect the High Pressure Pump. Use caution when changing filter elements and do not allow any debris from the pre-filter element to enter the outlet port of its housing.
5. Inspect the O-Ring and wipe with a damp cloth (or replace).
6. Sparingly lubricate the O-Ring with O-Ring lubricant.
7. In the case of the dual pre-filter element, place the O-Ring back into the bowl.
8. Insert the cleaned or new Sea Recovery Corporation Commercial or Dual Pre-filter Pleated Cartridge Element into the bowl.
9. Place the lid or bowl on top of the housing. For the Commercial Pre-filter element, replace the lid-locking ring as well. Tighten into place with hands. Do not use a wrench or other tool to tighten. Do not over tighten, as over tightening causes stress to the bowl and lid-lock ring threads, leading to cracks, breakage, and difficult disassembly at the next filter change.
10. In the case of the Commercial Pre-filter, open the Sea Cock Valve and the air bleed valve located on the lid. Bleed any air from the Commercial Pre-filter Housing. After water appears, close the air bleed valve. It may be necessary to operate the Booster Pump manually in order to purge the Commercial Pre-filter housing of air.

Caution: *ALWAYS* purge air from the pre-filter housing.

Oil/Water Separator Filter Element Replacement

The Oil/Water Separator Coalescing Filter Element cannot be cleaned. Clean or replace when blockage occurs (i.e., the pressure into the High Pressure Pump is equivalent to 10 PSI (69 kPa) or less. At slightly below 6 PSI (41 kPa), the System will turn off and display a fault screen.

1. Unscrew the lid-locking ring counter-clockwise.
2. Remove and discard the used Oil/Water Separator Filter Element.

-
3. Thoroughly clean the inside of the bowl. The High Pressure Pump is manufactured to a very tight tolerance spacing between moving parts. The pre-filter will catch debris and protect the High Pressure Pump. Use caution when changing filter elements and do not allow any debris from the pre-filter element to enter the outlet port of its housing.
 4. Inspect the O-Ring attached to the lid. Replace if damaged or if the lid leaks water.
 5. Wipe the O-Ring with a damp cloth.
 6. Sparingly lubricate the O-Ring with O-Ring lubricant.
 7. Insert the new Sea Recovery Corporation Oil/Water Separator Filter Element into the bowl.
 8. Place the lid on top of the housing.
 9. Replace the lid-locking ring. Tighten into place with hands. Do not use a wrench or other tool to tighten. Do not over-tighten, as over-tightening causes stress to the bowl and lid-lock ring threads, leading to cracks, breakage, and difficult disassembly at the next filter change.
 10. Open the Sea Cock Valve and the air bleed valve located on the lid. Bleed any air from the Oil/Water Separator Filter Housing. After water appears, close the air bleed valve. It may be necessary to operate the Booster Pump manually in order to purge the filter housing of air.

Transducer Manifold

The transducer manifold is irreparable. If broken or leaking, replace it.

Electric Motor and High Pressure Pump

Electric Motor

Refer to the topic [Electric Motor](#) on page 64 for electric motor troubleshooting instructions. If the High Pressure Pump electric motor fails to operate, follow the steps below to isolate the problem.

1. Check that the System is receiving the requisite power from the power source.
2. Press the **Start** button to start the system. It takes approximately 2 seconds before the High Pressure Pump Motor starts. Do not press any other switch.
3. Measure the AC voltage between terminals (AC Systems) or (DC systems) on the main terminal strip.
4. If the measured voltage is the System voltage, then the problem may be in the power cable attached to the motor, or the motor's internal wiring/windings.
5. If low or no voltage is present, then check for proper operation of the High Pressure Pump contactor. To deactivate the contactor, press the **Stop** button. To activate the contactor again, press the **Start** button.
6. If the contactor is mechanically operating, but no voltage is present at the motor terminals, then the High Pressure Pump Motor contactor may be at fault.
7. If the contactor does not operate mechanically, then measure the DC voltage between A1 and A2 terminals on the High Pressure Pump Motor contactor coil. It should read 12V DC when activated.
8. If the contactor coil is receiving 12V DC but inoperative then the contactor's coil may be bad. Replace the contactor.
9. If 12V DC is not present when the High Pressure Pump is activated, trace the wires to the main circuit board and measure the DC voltage at the terminals. It should read 12V when activated.
10. Confirm that the HP Pump **Stop** button is illuminated on the Touch Screen when the High Pressure Pump is activated. When the HP Pump **Stop** button is illuminated, the HP terminals on the Control Printed Circuit Board should be receiving 12 VDC. If this is not the case, then replace the main circuit board.

High Pressure (HP) Pump

The HP pump is a positive displacement plunger pump made of high-grade duplex material specifically designed for sea water Reverse Osmosis applications. This pump is not commercially available and is specifically manufactured to Sea Recovery Corporation specifications.

- As with all positive displacement pumps, the HP pump must receive a minimum amount of water at a positive pressure. A vacuum at the inlet of the pump will cause cavitation and damage.
- This pump does not use oil; it is self-lubricated with feed water. Internal components are designed for 8000 hours of continual service in sea water. As with any component exposed to sea water, use is best.

- This pump is manufactured to very tight tolerance spacing between moving parts. Any debris entering the pump will cause extensive and expensive damage to the internal parts. The Sea Recovery Pre-filter will stop any debris and protect the High Pressure Pump. Use caution when changing filter elements and do not allow any debris from the pre-filter element to enter the outlet port of its housing.
- If this pump requires maintenance within the warranty period, and--if after examination by Sea Recovery Corporation--is found to be non-operational due to a warranty failure, it will be repaired or replaced with a rebuilt pump at Sea Recovery Corporation's discretion. If the pump requires maintenance outside of the warranty period or is damaged due to non-warranty reasons, then it will be repaired or replaced (for a fee) with a rebuilt pump depending on the severity of damage. For repair or replacement, contact Sea Recovery for a Material Return Authorization and shipping instructions.

High Pressure Pump Problems and Solutions:

1. High Pressure Pump flow is normal when the System's operating pressure is below 100 PSI, but the flow drops or becomes erratic and pulsates as pressure is applied.
 - a. Worn High Pressure seals from normal use require replacement.
 - b. Worn High Pressure Pump's valves, valve seats, valve springs and or valve seat O-rings are broken or worn due to normal use and are allowing internal bypass. Repair the pump with a valve and seal kit.
2. High Pressure Pump is noisier than usual and pulsations are observed in hoses and gauges.
 - a. Worn or broken valve, valve spring or valve seat. Repair the pump with a valve and seal kit.
 - b. Pump is experiencing cavitation and is not receiving sufficient feed water at its inlet due to a blockage prior to the pump's inlet port. Clear the blockage in the feed water line.
3. High Pressure Pump Leaks Oil
 - a. Determine source of leak and replace appropriate associated seal.
4. High Pressure Pump leaks water between manifold and drive end.
 - a. Inlet Packings may be worn due to normal use; due to operation under a vacuum condition; or because pump has been operated dry, without inlet feed water.
 - b. Repair the pump with a seal kit.

High Pressure Hose

The High Pressure Hose has been assembled with crimp fittings. The High Pressure Hose is *NOT* repairable. Should leaks, damage, or failure develop, order a replacement hose from Sea Recovery Corporation.

Reverse Osmosis Membrane and Pressure Vessel Assembly

 **Note:** The System's RO Membrane Element is accessible with the vessel attached to the frame, provided that there is sufficient room to remove the element. You will need to replace all brine and product water O-Ring that are attached to the end plugs within the High Pressure Vessel Assembly each time the RO Membrane Element is removed or replaced. Ensure that the O-Rings are on-hand prior to repair. Refer to the instructions below, as well as the proceeding diagram, to disassemble the RO Membrane Element and Vessel Assembly. In this section, the numbers in brackets [#] refer to the reference numbers in the diagram.

 **Note:** RO Membrane Element must be installed and removed from the *INLET* end of the High Pressure Vessel.

Caution: At each end of the RO Membrane Element is a product water tube, approximately $\frac{3}{4}$ in. (1.9 cm) diameter by 1 in. (2.5 cm) long. The outside diameter surface of the product water tube is a sealing surface, which isolates the product water from the feed water. The surface of the Product Water Tube must be scratch free. Never use pliers or other grabbing tools on the Product Water Tube. Do not drop the RO Membrane Element onto a hard surface, as the Product Water Tube may be damaged.

-
1. Disconnect the High Pressure Hose from each end of the High Pressure Vessel Assembly.
 2. Using a 5/16" Allen wrench, remove the three Socket Head Cap Screws (#16) from the three-piece Segment Rings [14] located at each end of the Pressure Vessel.
 3. Push inward on the End Plug [3 and 4] and remove the three-piece segment ring [14] from one end. Repeat for the other end.
 4. Remove the Port Retainer [15] from each end.
 5. Remove the High Pressure Port [5 and 9] from each end.
 6. Remove the product water tube [13] from the product water tube fitting [12].
 7. Remove the product water tube fitting [12] and nipple [11] from the end plug.
 8. Insert the three Socket Head Cap Screws [16] (finger tightened) into the End Plug [3 and 4]. These screws are used as a grip to remove the End Plug.
 9. Grasp one or more of the Socket Head Cap Screws with a pair of pliers and pull slowly outward to remove the End Plug. There is some resistance due to the two Brine O-Rings exerting friction against the Vessel wall. With the End Plug removed from the High Pressure Vessel, the RO Membrane Element is visible.
 10. Remove and discard the brine O-Ring [6] from each end plug.
 11. Remove and discard the Product Water O-Ring [7] from each end plug.
 12. Clean end plugs with a cloth and inspect for any sign of wear, cracks or damage.
 13. Sparingly and lightly, lubricate a *NEW* Brine O-Ring and *NEW* Product Water O-Ring.
 14. Place the *NEW* product water O-Ring into the product port inner O-Ring groove (within each end plug).
 15. Place the *NEW* brine O-Ring onto the outer brine O-Ring grooves (within each end plug).
 16. With your fingers, grasp the Product Water Tube (attached to the RO Membrane Element) from the *INLET* end of the Pressure Vessel and pull outward. If resistance is met, then cup the *INLET* end of the High Pressure Vessel with one hand and shake downward to dislodge the RO Membrane Element. The RO Membrane Element may also be pushed from the *OUTLET* end of the vessel towards the *INLET* end.
 17. Run a rag through the High Pressure Vessel to remove biological film or debris from the inside of the vessel.
 18. A new Sea Recovery Corporation RO Membrane Element includes a "U" cup Brine Seal (#8) at one end of the element. The Brine Seal must be positioned at the *INLET* end of the Pressure Vessel.
 19. Install a new RO Membrane Element, with attached "U" cup Brine Seal, into the Pressure Vessel. Place the end of the RO Membrane Element (that which **DOES NOT** have the Brine Seal attached) into the *INLET* end of the Pressure Vessel, and slide it into the Pressure Vessel.
 20. Insert the downstream end (i.e., the end without a brine seal) of the RO Membrane Element into the upstream inlet end of the High Pressure Vessel.
 21. Slide the RO Membrane Element into the High Pressure Vessel (past the brine seal), until the membrane element's product water tube is 4 in. (10.2 cm) past the end lip of the High Pressure Vessel.
 22. Insert the End Plug (with newly attached O-Rings) into the High Pressure Vessel, while aligning the High Pressure Port and Product Water Port to the respective holes in the High Pressure Vessel. Continue pushing inward on the End Plug until the exposed end travels just past the Segment Ring Groove within the Pressure Vessel. Ensure that the End Plug's ports are aligned with the Port Holes of the High Pressure Vessel.
 23. Insert the High Pressure Port Fitting with attached O-Rings into the High Pressure Port.
 24. Replace the Port Retainer.
 25. Insert the three-piece Segment Ring Set into the Segment Ring Groove of the High Pressure Vessel. Align the Segment Ring Set with the tapped holes in the End Plug for insertion of the three Socket Head Cap Screws.
 26. Attach the three Socket Head Cap Screws and tighten.
 27. Connect the High Pressure Hoses to the respective fitting on the Pressure Vessel.

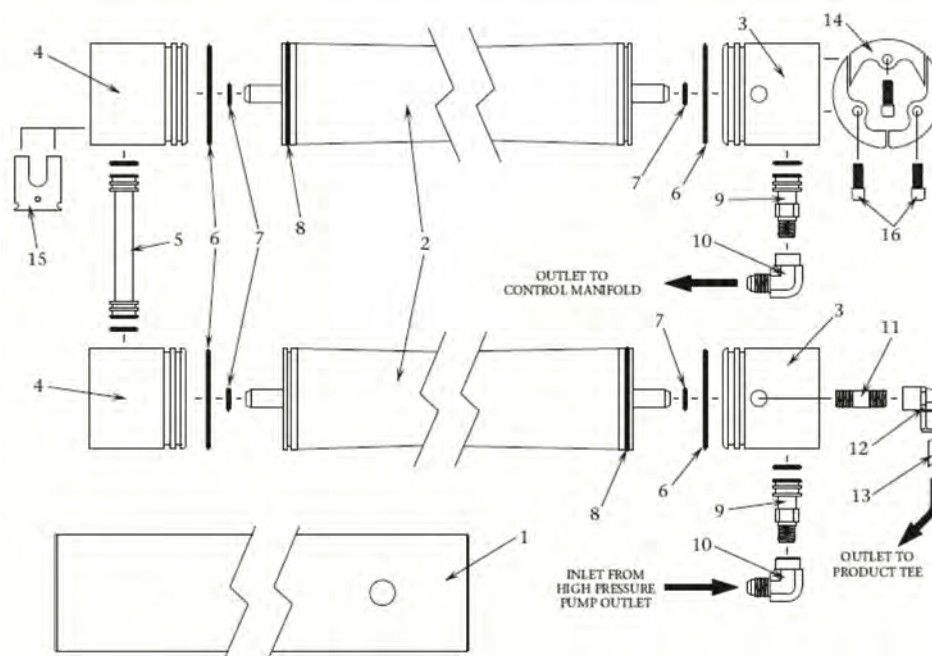

High Pressure Manifold

Replace the High Pressure Manifold if it is visibly cracked, broken and leaking. Replace the High Pressure fitting O-Rings if damaged, worn, or leaking.

High Pressure Transducer

Pressure Transducers are irreparable and cannot be calibrated. If inoperative, check connections at the transducer and at the Printed Circuit Board to ensure that there is no visible corrosion or loose connections.

Automatic Motor Actuated Back Pressure Regulator

The Motor Actuator and Gear Assembly are irreparable. If the motor has been confirmed to be non-operational, then it must be replaced.

Caution: If the valve stem and or Motor gear shaft is rotated separately from the other they must be replaced. If the coupler set screws have become loose allowing the shafts to rotate independently, or if repair has been performed where in the valve has been separated from the coupler or the motor gear shaft, then the motor gear shaft and the valve stem **MUST BE REPLACED**. If the valve stem has rotated separately from the motor gear shaft the control logic will not be able to maintain and control the system operating pressure.

Caution: Do not bench test the Electric Motor Actuator! **DO NOT APPLY DIRECT VOLTAGE TO THE ACTUATOR**. Bench testing of the motor can cause physical damage to the positioning signal device located within the Actuator assembly.



Important: Be sure to perform a function test on the Electric Motor Actuator as described in the topic [Manual System Check](#) on page 45.

Valve Packing Leak

If the Back Pressure Regulator valve leaks from the valve stem, lightly tighten the packing gland nut located below the valve stem. Should adjustment fail to stop the leak, replace the entire valve.

Caution: Do not over tighten the packing gland. Over tightening will cause premature wear and failure of the packing and stem.



Important: Over tightening can cause excessive drag, increasing the torque requirement of the valve's electric motor. Excessive drag resulting in an increased torque requirement will cause the valve motor to draw high current. When the valve's motor draws high current, the system's Control Logic will force the System to stop and the touch screen will display an error message.

When the actuator motor starts, it momentarily draws high current (this is normal). Once the motor begins to rotate (with no restrictions), the current lowers to normal running current. The motor, in turn, rotates the gear box, sensing POT (potentiometer) and valve stem. If motor movement is blocked or restricted, and does not rotate, it will draw high current and the sensing POT will not rotate. The System Control Logic receives a high current signal and ceases to sense POT movement. As a result, the System will stop and the touch screen will display an error message. To diagnose the restriction, perform the following steps:

1. Check the brass coupling that connects the valve stem and gear box shaft to ensure it allows free movement and turning.
2. Check for external signs of corrosion or water intrusion into the Actuator housing.
3. Ensure that the Valve Stem packing nut is not over tightened causing friction and resistance.

Brine Discharge and Product Water Flow Meters

The System's electronic flow meters are irreparable. If a flow meter generates inaccurate readings, then it must be replaced.

Brine Discharge T-Connector

The Brine Discharge T-Connector is irreparable. If it breaks or develops a crack, then it must be replaced.

Brine Discharge Connector

This connector is a 90 degree elbow fitting that attaches to the over board thru-hull fitting for connecting the brine discharge hose. If it breaks or develops a crack, then it must be replaced.

Multi Media Filter Waste and Brine Discharge Tee

This tee is a 90 degree elbow fitting that attaches to the over board thru-hull fitting for connecting the brine discharge hose. If it breaks or develops a crack, then it must be replaced.

Thru-Hull Discharge Fitting

Not reparable; if it breaks or develops a crack, then it must be replaced.

Product Water T-Collector

Not reparable; if it breaks or develops a crack, then it must be replaced.

Salinity Probe

The salinity probe requires cleaning when debris builds up on the monel probes. Clean the probes once a year according to the procedures below.

1. Unscrew the black tube fitting nut (below the probe) to disconnect it from the control manifold.
2. Using a soft bristle brush, scrub the probes to remove any built up debris.
3. Thoroughly dry the probe area.
4. Should the salinity reading become inaccurate, replace the probe.

3-way Product Water Diversion Solenoid Valve

- ✓ **Note:** Do not assume that the valve's solenoid is non-operational. Check it by performing a function test as described in the topic [Manual System Check](#) on page 45.

Caution: Over tightening the tube fittings can cause the diversion valve's internal ports to move out of the proper position, thereby causing internal blockage or bypass.

Follow the steps below to check the diversion valve for problems.

1. Remove Diversion Valve from the system.
2. Position the **Manual Override** button *OUTWARD* (to the normal position) by first pushing the button inward and then rotating counter clockwise, allowing it to spring outward and away from the coil body.
3. With your mouth, blow into port "P." Air should expel from port "B," which is the "normally open" or "bad water" port.
 - a. If you encounter significant resistance when attempting to expel air from port "B" (or if no air expels from port "B"), then replace the valve.
4. Blow into port "P" again, while plugging port "B" with your fingertip. No air should expel from port "A."
 - a. If air expels from port "A", then replace the valve.
5. Position the **Manual Override** button *INWARD* (to the manual override position) by first pushing the button inward and then rotating it clockwise, allowing it to lock inward (close to the coil body).
6. With your mouth, blow into port "P." Air should expel from port "A," which is the "normally closed" or "good water" port.
 - a. If you encounter significant resistance when attempting to expel air from port "A" (or if no air expels from port "A"), then replace the valve.
7. Blow into port "P" again, while plugging port "A" with your fingertip. No air should expel from port "B."
 - a. If air expels from port "B," then replace the valve.

Follow the steps below to check the condition of the Diversion Valve solenoid coil.

- ✓ **Note:** The 3-way Product Diversion Valve Solenoid operates from 12 VDC.
1. While the System is operating and producing potable water, use a voltmeter (set to DC) to check the voltage at the din connector terminals (top of solenoid).
 2. If 12 VDC is present at the din connector terminals, then the control circuit is operating normally; however, the 3-way Diversion Valve Coil may be shorted or open. Check the solenoid coil continuity. Note that this check can only be performed when the solenoid is electrically disconnected from the Control Board.
 3. Remove the din connector from the solenoid. Using an Ohm meter, measure the continuity of the solenoid coil as shown below.
 4. If an open circuit exists, or if the resistance is much greater than (or less than) 12 to 15 ohms, then replace the solenoid coil or the entire valve.
 5. If 12 VDC is not present at the din connector terminals, then the cable connections may be loose, the cable may be broken, or the control circuit may be inoperable. Check these components.
 6. Check for 12 VDC at the connection points of the Diversion Valve Solenoid Coil on the Control Printed Circuit Board terminals.
 7. If 12 VDC is present while system is operating, then the Diversion Valve cable is loose at one of the connections or the cable is defective.
 8. If there is no voltage present while system is operating, then troubleshoot the Control Printed Circuit Board.

Charcoal Filter

A sulfurous (rotten eggs) odor from the product water indicates that the Charcoal Filter element must be replaced. Otherwise, the Charcoal Filter element must be replaced every three to four months (it cannot be cleaned).

Caution: Do not use third-party charcoal or carbon filter elements! Use only Sea Recovery Corporation Filter Elements. Many third-party Filter Elements fit improperly; the seams fall apart; and they allow bypass. They are also designed for low flow rates, causing extensive damage (due to pressure build-up on the product water line) if used in the System. Excessive pressure resulting from third-party Charcoal or Carbon Filter Elements will damage the following System components: the RO Membrane Element, the Product Water Flow Meter, the 3-Way Product Water Diversion Valve, the Charcoal Filter Housing and the Product Water Line.



Important: *DO NOT ACCEPT THIRD-PARTY CHARCOAL FILTER ELEMENTS FROM ANY MARINE DEALER. USE ONLY SEA RECOVERY SUPPLIED CHARCOAL OR CARBON FILTER ELEMENTS.* The System's resulting failure, and/or damage to the System caused by third-party pre-filter elements, is attributed to improper maintenance and operation, is the liability of the operator and owner, and is not covered by the Sea Recovery Corporation warranty.

To replace the Charcoal Filter Element, follow the procedures below.

1. Unscrew the bowl counter-clockwise.
2. Remove the Charcoal Filter Element from the bowl.
3. Remove the O-Ring from the top of the bowl.
4. Replace the Charcoal Filter Element with a new Sea Recovery Corporation element.
5. Wipe the O-Ring with a damp cloth.
6. Sparingly lubricate the O-Ring with O-Ring lubricant.
7. Place the O-Ring back onto the bowl.
8. Insert the new, Charcoal Filter Element into the bowl.
9. Screw the bowl on clockwise.
10. Hand turn to seal the O-Ring. Do not use a wrench or other tool to tighten, and do not over tighten. Over tightening causes stress to the lid and bowl threads, which can result in damage, breakage, or cracks, as well as difficulty removing it in the future.

pH Neutralizing Filter

The pH Neutralizing cartridge requires replacement when the calcium carbonate (within the cartridge) has dissolved. To replace the pH Neutralizing Cartridge, follow the procedures below.

1. Unscrew the bowl counter-clockwise.
2. Remove the pH Neutralizing Cartridge from the bowl.
3. Remove the O-Ring from the top of the bowl.
4. Replace the pH Neutralizing Cartridge with a new Sea Recovery Corporation cartridge.
5. Wipe the O-Ring with a damp cloth.
6. Sparingly lubricate the O-Ring lightly with O-Ring lubricant.
7. Place the O-Ring back onto the bowl.
8. Insert the new, Sea Recovery pH Neutralizing Cartridge into the bowl.
9. Screw the bowl on clockwise.
10. Hand turn to seal the O-Ring. Do not use a wrench or other tool to tighten, and do not over tighten. Over tightening causes stress to the lid and bowl threads, which can result in damage, breakage, or cracks, as well as difficulty removing it in the future.

Ultraviolet Sterilizer

The UV Sterilizer lamp emits low frequency light. The light degrades and loses intensity, as well as its ability to sterilize biological matter over approximately 8000 hours of use. Therefore, the lamp may remain lit, but requires replacement every 4400 to 8000 hours.

Danger: UV light is harmful to eyes and skin! Check that system power is turned **OFF** before beginning sterilizer maintenance.

Lamp Replacement

1. Remove the four screws on the ballast box.
2. Remove lid.
3. Remove rubber boot and carefully pull lamp out of quartz sleeve.
4. Replace the lamp.

 **Note:** During lamp replacement, clean the quartz sleeve as well. The quartz sleeve should be clear. If discolored, it must be cleaned or replaced.

Quartz Sleeve Cleaning

1. Remove the four screws on the ballast box.
2. Remove lid.
3. Remove rubber boot and carefully pull lamp out of the quartz sleeve.
4. Unscrew and remove two compression nuts (ballast box and view port).
5. Remove the O-ring on the view port side only.
6. Carefully pull the quartz sleeve out from the ballast box side.
7. Clean the quartz tube with water and a bottle brush without moving the O-ring. Dry with a soft cloth. Handle the quartz sleeve carefully.

Reassembly

1. Replace old O-rings with new O-rings.
2. Insert the quartz sleeve (close-end first) through the ballast box pass thru until O-ring contact pass thru. Screw on the ballast box compression nut. Insert view port O-ring and screw on view port compression nut.
3. Attach a new UV Lamp into the plug.
4. Slide the lamp into the Quartz Sleeve and install rubber boot over the compression nut.
5. Replace the three ¼-20 cap head screws.

Fresh Water Flush Carbon Filter Element

The Carbon Filter Element in the Fresh Water Flush must be replaced every three months. The Fresh Water Flush will automatically flush the system with Fresh Water every preset number of days. The duration of the flush cycle will be 90 seconds for a system connected to 60 Hz power and to 120 seconds for systems connected to 50 Hz power. To replace the Carbon Filter Element, follow the procedures below.

1. Unscrew the bowl counter-clockwise.
2. Remove the Carbon Filter Element from the bowl.
3. Remove the O-Ring from the top of the bowl.
4. Replace the Carbon Filter Element with a new Sea Recovery Corporation element.
5. Wipe the O-Ring with a damp cloth.
6. Sparingly lubricate the O-Ring lightly with O-Ring lubricant.
7. Place the O-Ring back onto the bowl.
8. Insert the new Sea Recovery Carbon Filter Element into the bowl.

9. Screw the bowl on clockwise.
10. Hand turn to seal the O-Ring. Do not use a wrench or other tool to tighten, and do not over tighten. Over tightening causes stress to the lid and bowl threads, which can result in damage, breakage, or cracks, as well as difficulty removing it in the future.

UV Sterilizer Maintenance

Follow the maintenance procedures in this topic to maximize the efficiency, reliability and longevity of the UV Sterilizer. The table below represents the recommended Periodic Maintenance (PM) for the SP Series UV Unit.

Description	Initial	Daily	Monthly	Annual	Other
Quartz Sleeve Cleaning	x				
Quartz Sleeve Replacement ³	x				
Operating Condition	x				
Unit Cleaning	x		x		
Leak Inspection	x	x	x		
UV Lamp Inspection	x	x	x		
UV Lamp Replacement-SP-1				x	4400 hrs
UV Lamp Replacement-SP-2				x	8000 hrs

Before performing any maintenance, you must review the safety requirements below. Failure to comply with these safety requirements can cause injuries to you and others, as well as damages to the UV unit. Above all else, consider your personal safety. Operators must observe Safety Requirements at all times, and only qualified service personnel should perform maintenance on the UV unit.

Danger: UV light exposure can severely burn/damage eyes and skin! Never look directly at the UV lamp when it is turned **ON**. Never operate the UV lamp outside the stainless steel cabinet.

Danger: Properly ground the UV unit. Failure to properly ground the UV unit can cause severe electrical shock hazard. Disconnect power before servicing the UV unit. The UV lamp and electrical components operate with high voltage electrical power. Do not attempt to service the UV unit without first disconnecting the power source. Shut off the source of power at the main panel breaker and use appropriate lock-out/tag-out procedures to prevent accidental power-up.

Danger: Provide watertight piping and compression nut seals. Failure to provide watertight seals can cause damage to electrical components or cause electrical shock hazard.

Caution: Remove pressure before servicing the UV unit.

Caution: Never operate the UV unit for more than 30 minutes without water flow. Elevated water temperature can damage the UV unit.

Caution: Do not exceed three "Start/Stop" cycles per 24-hour period. Exceeding three cycles will subject the lamp filament to excessive thermal stress, leading to premature failure of the UV lamp.

UV Unit Specifications

³ Quartz Sleeve replacement will occur more frequently for systems operating with continuous high flow rate or low water quality water, and less frequently for systems operating with low flow rate or high water quality.

Type	12 VDC Operating UV Sterilizer for 2 gallon (7.5 liters) per minute of water flow
Ballast Type	Solid State
Bulb Type	16 Watts Single Ended
Bulb Life	8000 Hours minimum
Materials	Body: SS304; Ballast Box: PVC
Power Cord	13 ft (4 meters) 2 conductors
Weight	1 lbs (500g) Body
Temperature Range	Operating: 37°F to 104°F (3°C to 40°C); Dry Storage: -4°F to 185°F (-25°C to 85°C)
Operating Voltage Range	10.56V minimum; 16.50V maximum
Current	1.45A maximum @ Standard Test Voltage
UV Dosage	22mJ/cm ² @ 254nm
Operating Pressure	50psi (3.4 bar)
Inlet/Outlet Ports	¼ in. (6.3 mm) NPT Female
Flow Rate	2 gpm (7.5 lpm)
Disinfection Rate	99%

Exterior Surfaces

The exterior surfaces of the UV unit must be kept clean and dry. In most cases, the unit's exterior must be cleaned once per month. Use a soft cloth and soapy water, or any commercial stainless steel cleaner. The ballast box's interior should be inspected for debris. Debris can be removed using vacuum.

Quartz Sleeve

Debris and other matter in the water will settle onto the quartz sleeve and eventually block the UV rays from penetrating into the water. It is necessary to determine a cleaning schedule for the quartz sleeve. The frequency will depend on the specific type of water being processed and the duty cycle of the unit. Inspect the quartz sleeve 30 days after initial installation to assess the amount of contamination collected over the 30-day period. Use the finding to determine a reasonable schedule and frequency for periodic cleaning. Clean-In-Place (CIP) cleaning is sometimes effective in removing debris from the quartz sleeve. Conduct a CIP cleaning test to determine its effectiveness. If CIP cleaning is not effective, then a manual cleaning or replacement is required. When the quartz sleeve is due for cleaning, follow the procedures below.

1. Turn off the water source to the UV unit.
2. Disconnect the power source to the UV unit.
3. Drain the UV treatment chamber.
4. Remove the ballast box cover.
5. Remove rubber boot and carefully pull out the UV lamp through the compression nut pass-thru.
6. Use a channel lock to remove the compression nuts.
7. Remove the Quartz Sleeve.
8. Wash the Quartz Sleeve with mild, soapy water and rinse in clean, hot water.
9. If dirt remains after rinsing, the quartz sleeve must be replaced. Contact your local CSR to order a replacement.

Failure to perform quartz sleeve maintenance may reduce the UV light's effectiveness in treating water within the treatment chamber.

Checking for Leaks

Visual inspect the UV unit's exterior for signs of leakage. Leaks must be repaired immediately. If a leakage is detected, perform the following procedures:

-
1. Shut off power at the main panel breaker and use appropriate lock-out/tag-out procedures.
 2. Depressurize the UV unit.
 3. Remove ballast box cover and the rubber boot.
 4. Locate the leak.

Repairing Leaks

If both ends of the quartz sleeve are leaking, perform the following procedures on both ends:

1. Use a channel lock to loosen and remove the compression nut.
2. Remove the quartz sleeve O-ring (without pulling the quartz sleeve out).
3. Lubricate the quartz sleeve tip with clean water and place new O-ring. Ensure the O-ring makes consistent contact with the cylinder pass-thru.
4. Replace and tighten the compression nut.
5. Refill the treatment chamber and verify leak-free conditions.

Measuring Performance

Every UV unit must be tested periodically to verify efficiency. Regardless of the intended application or any optional equipment provided with the UV unit, the most accurate procedure is a Post-UV Analysis. The Post-UV Test must be performed in accordance with standard testing methods.

Verifying Lamp Operation

The UV lamp is **ON** when blue light is emitting thru the viewport.

Obtaining Water Samples

The vast majority of unsatisfactory Post-UV Test results are directly related to improper sample-taking techniques. Although several commercial sample collection apparatuses are available, proper manufacturer's procedures must be followed.

1. Use sterile sample bottles (obtained from reliable laboratory) that have been autoclaved and stored in plastic.
2. Use a temporary tube to direct water from the UV unit to a container or drainage.
3. Pressurize the UV unit and flush unit with sample valve that is fully opened for 3.5 minutes. Sea Recovery Corporation recommends using a valve that has a discharge orifice smaller than ¼" (6mm). After flushing for 3.5 minutes, reduce valve opening to 50% and flush for 3 minutes.
4. Open the sample bottle and keep the inside of the cap face-down.
5. Fill the sample bottle and avoid breathing directly into the bottle or touching the inside of the bottle, cap and neck.
6. Immediately cover and secure the cap after filling the sample bottle.
7. Label the sample bottle and place in a clean plastic bag.
8. Take sample bottle to the laboratory for plating as soon as possible.



Important: Sample processing must begin within three hours after sample collection and must comply with accepted standard methods.

Chapter 8

Troubleshooting

This chapter provides information and procedures for troubleshooting abnormal System behavior. For each symptom, one or more causes are provided, and each includes one or more corresponding tests to help identify the correct cause of the problem and correct it. When diagnosing System issues, eliminate the listed causes one-by-one until the correct cause is found.

Alarm and Error Screens

Alarm and error screens provide information to the Operator on the System's condition. The alarm message (yellow background) or error message (red background) state the problem and recommend possible corrective action(s) to eliminate the system alarm/error.



The following alarm and error messages are possible:

- Fresh Water Tank full.
- Product flow was out of specifications. Check for leaks and wiring connections.
- Conductivity sensor (#) failed measuring. Check wiring.
- Fresh Water Tank was too low. Fresh Water Flush stopped.
- Flow error in the Fresh Water Flush Operation. Check for leaks or blockage in the Fresh Water Supply.
- Product flow is low. Check water temperature and reverse osmosis membrane.
- Unable to communicate with the selected watermaker. Check the water maker.
- The TDS salinity level at the product water line is too high. The system is unable to clean the water. Check for mechanical failure.
- Pressure drop on inlet Filters to excessive. Check filters.
- User initiated emergency break.
- Power has been interrupted while the system was in operation. The system will not restart automatically.
- Inlet Pressure of the High Pressure Pump dropped below specifications. Check Booster Pump and filters.
- Outlet pressure of High Pressure Pump exceeded the specifications. Check Brine Discharge, Product Water lines and Post Filtration.
- Brine Discharge flow was out of specifications. Check for leaks and wiring connections.
- Back Pressure Regulator is stuck. Check for a mechanical failure and wiring connections.

-
- Warning on the water maker. For detailed information please check warning on the water maker display.
 - Alarm on the water maker. For detailed information please check alarm on the water maker display
 - Low Pressure Sensor (#) failed to measure the pressure. Check wiring.
 - High Pressure sensor failed to measure the pressure. Check wiring.
 - Temperature Sensor (#) failed to measure the temperature. Check wiring.

Thru-Hull Inlet Fitting

1. Problem: Flat profile Inlet Thru Hull Fitting

- a. Description: System runs properly at anchor; however, when underway, the System shuts off due to low pressure or low feed water flow. A flat profile Inlet Thru Hull Fitting is causing a vacuum at the System's feed line, thereby cavitating and reducing the efficiency of the Booster Pump. This results in low feed water pressure and low feed water flow.
- b. Solution: Change the flat profile Thru Hull Fitting to a forward facing scoop.

2. Problem: Debris is blocking the Inlet Thru Hull Fitting

- a. Description: System feed water pressure is low and insufficient to keep the System in operation. Marine growth or debris (e.g. a plastic bag or rag) covering the Inlet Thru-Hull Fitting is causing a vacuum at the System's feed line, thereby cavitating and reducing the efficiency of the Booster Pump. This results in low feed water pressure and low feed water flow.
- b. Solution: Clean all marine growth and debris from the Inlet Thru-Hull Fitting.

3. Problem: System is newly installed and operation is being performed for the first time. The feed water pressure is low and insufficient to keep the System in operation.

- a. Description: A new ship, or newly installed System, may have protective shipping tape covering the Inlet Thru-Hull Fitting. A new ship, or newly installed System, may also have manufacturing debris (such as caulking) blocking the Inlet Thru Hull. Lastly, a new Inlet Thru-Hull Fitting may have casting slag (that which has not been machined off) partially covering the "fingers" or inside of the fitting.
- b. Solution: Inspect the Inlet Thru-Hull Fitting and clean all manufacturing debris and casting slag from the fitting.

Sea Cock Valve

1. Problem: The Sea Cock Valve is closed when attempting to start the System.

- a. Description: The System does not register feed-water flow and feed-water pressure when attempting to start. An error screen appears and the System shuts down. When the System is not in use, it is good practice (for the safety of the ship) to close the Sea Cock Valve. Don't forget to open it prior to starting the System.
- b. Solution: Open the Sea Cock Valve.

2. Problem: The Sea Cock Valve seal is worn or the seal is loose, causing air to enter the System Feed Line.

- a. Description: System feed water pressure is low and insufficient to keep the System in operation. This section of the Feed Line is under a vacuum condition when the System is in operation. If the valve's seal is worn or loose, air can enter the feed line causing the System to lose pressure. Look for air bubbles moving through the Sea Strainer or feed line.
- b. Solution: Change the valve seals, tighten them, or replace the valve (if necessary).

Inlet Connection

(Includes all fittings and connections prior to the inlet of the Booster Pump)

1. Problem: One or more fittings/connections is causing air to enter the Feed Line.

- a. Description: System feed water pressure is low and insufficient to keep the System in operation. This section of the Feed Line is under a vacuum condition when the System is in operation. Look for air bubbles moving through the Sea Strainer or feed line.
- b. Solution: Tighten any loose fitting or connection at the Inlet of the Booster Pump or prior to it that is allowing air to enter the feed line. Replace worn or broken seal or O-ring at the Inlet of the Booster Pump or prior to it that is allowing air to enter the feed line. Check positioning of all valves at or prior to the Inlet of the Booster Pump that may be allowing air to enter the feed line.

Inlet Vacuum/Pressure Gauges

1. Problem: A Vacuum/Pressure gauge needle does not move or does not register proper vacuum or pressure.

- a. Description: Vacuum/Pressure Gauges have a narrow orifice at the bottom of the pipe fitting end. This orifice can become plugged with debris or corrosion.
- b. Solution: Using a small diameter wire, clean the debris from the orifice.

Sea Strainer

1. Problem: System feed water pressure is low and insufficient to keep the System in operation because the O-Rings are not properly seated, are worn, or are not properly compressed allowing air to enter the Feed Line.

- a. Description: This section of the Feed Line is under a vacuum condition when the System is in operation. If the Sea Strainer O-Ring is not properly seated, air will enter the feed line causing the System to lose pressure. Look for air bubbles moving through the Sea Strainer and into the Feed Line.
- b. Solution: Properly seat or replace the Sea Strainer O-Ring.

2. Problem: System feed water pressure is low and insufficient to keep the System in operation because the Sea Strainer mesh screen is blocking feed water flow.

- a. Description: The Sea Strainer mesh screen element is the first line of defense to trap large suspended solids entering the Feed Line. Depending on Feed Water conditions the screen may plug up rapidly. Marine growth, plastic bags, jelly fish, and other debris can easily enter the feed line and plug up the Sea Strainer mesh screen.
- b. Solution: Regularly check and clean the Sea Strainer mesh screen. Keep it clear and free of debris.

Booster Pump

The Booster Pump is a centrifugal pump. When mounted at or below feed water level, it is able to draw the feed water and deliver it with pressure into the pre-filtration components and High Pressure Pump. If mounted above feed water level, the Booster Pump may have trouble priming when air enters the feed line. Prior to assuming that the Booster Pump's Electric Motor has failed, perform a Function Test as described in [Manual System Check](#) on page 45.

1. Problem: The Booster Pump leaks feed water between the pump and motor.

- a. Description: The Booster Pump has a ceramic and carbon seal. Ceramic and carbon seals will weep if the pump is not operated for extended periods of time. When used regularly, the seal will give approximately 2000 hours of use. The seal continually wears during use and must be replaced approximately every 2000 hours of use. If left unused for extended periods of time, seal replacement may be required sooner.
- b. Solution: Replace seal.

T-Connector Pressure Pickup

1. **Problem: Low Pressure Transducer does not register pressure.**
 - a. Description: The ¼ in. (5 mm) O.D. tube connecting the T-Connector to the Low Pressure Transducer Manifold may become kinked or debris may block the tube.
 - b. Solution: Replace any hose or tube that is kinked. Disconnect each end of the tube and blow air through the tube to ensure that it is not blocked.

Pressure Transducers

-  **Note:** The System's Pressure Transducers send a DC voltage signal to the System Control Logic. The minimum value is 0.5 VDC when no pressure is applied to it, and the maximum value that the System will accept is 4.5 VDC. The variation of voltage output from the transducer is converted to pressure value by the System Control Logic.

1. **Problem: (For Pressure Differential Transducer) Does not display on the Touch Screen.**
 - a. Solution: Refer to [Controller Setup](#) on page 42 to set up and inform the System Control Logic that the Pressure Differential Transducer has been installed and connected.
2. **Problem: The Transducer does not register pressure or the pressure displayed is inaccurate.**
 - a. Description: The connecting tube may become kinked or debris may block the tube.
 - b. Solution: Replace any hose or tube that is kinked. Disconnect each end of the tube and blow air through the tube to ensure that it is not blocked.
3. **Problem: The pressure readings at the Touch Pad are inaccurate.**
 - a. Description: The minimum voltage output is below 0.5 VDC and or the maximum voltage output is above 5 VDC.
 - b. Solution: Check wiring and connections to and from the Transducer. Replace the Transducer.

Plankton Filter

1. **Problem: The Feed Water Pressure into the Plankton Filter is higher than normal, and the Feed Water Pressure into the High Pressure Pump is lower than normal.**
 - a. Description: The pressure differential readings across the Plankton Filter indicate that the element is filled with debris blocking the feed water.
 - b. Solution: Clean the Plankton Filter Element.

Multi Media Filter

1. **Problem: The Feed Water Pressure into the Multi Media Filter is higher than normal, and the Feed Water Pressure into the High Pressure Pump is lower than normal.**
 - a. Description: The pressure differential readings across the Multi Media Filter indicate that the Multi Media Filter requires back washing.
 - b. Solution: Back wash the Multi Media Filter.

Dual Pre-Filter

1. **Problem: The Feed Water Pressure into the Pre-filter is higher than normal, and the Feed Water Pressure into the High Pressure Pump is lower than normal.**
 - a. Description: The pressure differential readings across the Pre-filter indicate that the elements are filled with debris blocking the feed water.
 - b. Solution: Replace the Prefilter Elements.

Commercial Pre-Filter

1. **Problem: The Feed Water Pressure into the Prefilter is higher than normal, and the Feed Water Pressure into the High Pressure Pump is lower than normal.**
 - a. Description: The pressure differential readings across the Pre-filter indicate that the element is filled with debris blocking the feed water.
 - b. Solution: Replace the Pre-filter Element.

Oil and Water Separator

1. **Problem: The Feed Water Pressure into the Oil/Water Separator is higher than normal, and the Feed Water Pressure into the High Pressure Pump is lower than normal.**
 - a. Description: The pressure differential readings across the Oil/Water Separator indicate that the element is filled with debris blocking the feed water.
 - b. Solution: Replace the Oil/Water Separator Element.

Std HP Pump Assembly

Prior to assuming that the High Pressure Pump's Electric Motor has failed, perform a function test.

1. **Problems: The Single Phase (115 or 230 VAC) Electric Motor “hums,” pulls starting current (locked rotor) amperage, does not rotate, and trips the supply power circuit breaker when attempting to operate the System.**
 - a. Description: The Single Phase Electric Motor is a capacitor start motor. If the motor was started with low voltage, a drop in voltage during starting, and if this was repeated several times in rapid concession the capacitor will short out. Without the aid of a working capacitor the motor will “hum”, pull starting current (locked rotor) amperage, not rotate, and trip the supply power circuit breaker when attempting to operate the System. Low voltage will also cause the same symptom. Low voltage is caused by an undersized power supply or generator, undersized power lead wires to the System or motor, loose power wire, or connection at the motor or within the power supply line, and “burnt” contacts on the motor starter relay (contactor).
 - b. Solutions:
 - a. Check wiring size and connections to, from, and in between the Power Supply and the electric motor. Correct wire size or any loose wires.
 - b. Check the capacitor on the motor, and replace it if it has shorted out.
 - c. Measure voltage at the motor during attempt to start it. If voltage drops more than 10% locate and correct the reason.
 - d. Check the motor starter relay (contactor) for “burnt” contacts.
2. **Problems: The Three Phase (230/380/460 VAC) Electric Motor “hums,” pulls starting current (locked rotor) amperage, does not rotate, and trips the supply power circuit breaker when attempting to operate the System.**

-
- a. Description: The Three Phase Electric Motor requires all three power lines (all three phases) to be operative else it will “single phase” causing extensive damage to the motor’s internal windings. Low voltage will also cause the same symptom. Low voltage is caused by an undersized power supply or generator, undersized power lead wires to the System or motor, loose power wire, or connection at the motor or within the power supply line, and “burnt” contacts on the motor starter relay (contactor).
 - b. Solutions:
 - a. Check wiring size and connections to, from, and in between the Power Supply and the electric motor. Correct wire size or any loose wires.
 - b. Measure voltage at the motor during attempt to start it. If voltage drops more than 10% locate and correct the reason.
 - c. Check the motor starter relay (contactor) for “burnt” contacts.
 - d. Ensure all three phases have power.

3. Problem: The Electric Motor makes an unusual “grinding” sound when operated.

- a. Solutions:
 - a. Check to see if the fan is rubbing against the fan guard.
 - b. Replace motor, as required.

4. Problem: The High Pressure Pump makes an unusual “grinding” sound when operated.

- a. Description: The pump will make a grinding noise if its drive shaft has been forced into the pump body. The Electric Motor and Pump are coupled with a “Flex Coupler” specially designed for use with this specialized pump. Never replace the Flex Coupler with another make or style. ALWAYS leave 3/32 in. (2mm) spacing between the two mating Flex Couplers. ALWAYS ensure that the Safety Bell Housing attached to the electric motor and the pump seats evenly on both ends. Internal spacing of moving components within the High Pressure Pump hold to very tight tolerance. Any debris larger than 10 micron entering the High Pressure Pump will cause abrasion to the pump’s internal parts, and will cause an audible grinding noise. Hard debris, such as sand or metal, will cause the pump to “freeze up” and will cause extensive damage to the internal parts of the pump. If the System incorporates a Multi Media Filter use caution to not allow sand to enter the High Pressure Pump. When changing Prefilter Elements use caution to not allow debris to enter the High Pressure Pump. Damage to the High pressure Pump caused by debris is the responsibility of the person performing maintenance to the System, is the liability of the person performing maintenance to the System, and is not covered by the Sea Recovery warranty.
- b. Solutions:
 - a. Check spacing between the motor’s and pump’s flex coupler. Spacing must be minimum 3/32 in. (2mm) and maximum 1/8 in. (3mm).
 - b. Check Safety Bell Housing to ensure it is flush and secured to both the motor and pump.
 - c. Check Pump for signs of foreign debris entering the inlet.

5. Problem: Decreased Pressure

- a. Description: The High Pressure Pump flow and or pressure have decreased from normal. As with all High Pressure Pumps, over time of operation flow and pressure will decline due to internal wear. Under normal use and care no significant pressure or flow loss will occur for 8,000 hours of operation or longer. Do not confuse low feed water flow and low feed water pressure with a High Pressure Pump problem. All positive displacement pumps must receive a specific flow at a minimum pressure else cavitation will occur. Check to ensure that the Booster Pump is delivering at least 4.5 U.S. Gallons (17 Liters) Per Minute of feed water at 10 to 40 PSI (69 to 276 kPa) at the Inlet of the High Pressure Pump. Note: Systems operating on 50 Hz power will deliver 3.75 U.S. Gallons (14.2 Liters) Per Minute of feed water.
- b. Solution: If Feed Water Flow and Pressure into the High Pressure Pump are within minimum specifications, and if the electric motor is rotating at the proper rotation (the proper cycles are present from the power source) yet the High Pressure Pump has lost Flow and or Pressure then return the High Pressure Pump to Sea Recovery for servicing.

6. Problem: Leaks between Pump and Motor

- a. Description: The High Pressure Pump leaks water between the pump and motor. The HP Pump has a ceramic and carbon seal. Ceramic and carbon seals will weep if the pump is not operated for extended periods of time. When used regularly the seal will give approximately 8,000 hours of use. The seal continually wears during use and must be replaced approximately every 8,000 hours or at the sign of leakage.
- b. Solution: Return the High Pressure Pump to Sea Recovery for service and Seal replacement.

7. Problem: Knocking Noise

- a. Description: The High Pressure Pump makes an unusual and loud “knocking” noise. All positive displacement pumps will make a very loud knocking noise if they do not receive sufficient flow at a positive pressure. This knocking noise results from cavitation which is caused by insufficient feed water flow at an insufficient pressure.
- b. Solution: Service the Pre filtration Section (Low Pressure Section) of the System. Check all components between the Inlet Thru-Hull Fitting and the Inlet of the High Pressure Pump to determine what is causing the loss in feed water flow and pressure to the High Pressure Pump.

HP Pump Assembly

1. Problem: Pulsations at low and high pressure gauges.

- a. Description: Worn or broken valve, valve spring, valve seat. Debris in valve chamber.
- b. Solution: Check valve chamber for debris, inspect valve seat. Replace valve assembly as necessary.

2. Problem: Water leaks between the pump manifold and rear crankcase section.

- a. Description: Worn seals or seals damaged due to running dry.
- b. Solution: Inspect seals and replace if necessary.

3. Problem: Normal flow when not pressurized but flow drops dramatically when pressurized.

- a. Possible cause: Worn seals or seals damage due to running dry, broken valve, valve spring, or debris in valve chamber.
- b. Solution: Check seals and valve chambers, clean chamber or replace parts as necessary.

RO Membrane and Assembly

Is your System experiencing one or more of the following issues?

- The System does not produce the correct amount of Product Water (too much or too little)
- The System produces poor quality Product Water, high in salinity
- The System Operating Pressure is excessively higher than 800 PSI (55 BAR) when operating in normal Sea Water at moderate temperatures (77°F or 25°C)
- The System Operating Pressure is excessively lower than 800 PSI (55 BAR) when operating in normal Sea Water at moderate temperatures (77°F or 25°C)

If yes, then first check that the RO Membrane Element has been properly set up.

1. Problem: Product Water Flow suddenly and dramatically increases and Product Water Salinity increases making the Product Water non-potable.

- a. Descriptions:
 - a. The Pressurized Feed Water and the un-pressurized Product Water are separated by an O-Ring which seals on the Product Water Tube at each end of the RO Membrane Element and the End Plug at each end of the Pressure Vessel. Should this O-Ring fail, Feed Water will mix with Product Water. If this happens, the Product Water will be very salty, the Product Water Flow will increase dramatically, and the Brine Flow will decrease appropriately (by the increase in Product Water).

-
- b. If the end plug develops a crack (between the product water port and the pressurized feed water), a similar increase in Product Water flow and high Product Water salinity will occur.
 - c. At ONE end of the RO Membrane Element, there is a “U” cup seal referred to as the “brine seal.” NEVER use two Brine Seals. NEVER place a Brine Seal on both ends of the RO Membrane Element. This will cause an air pocket between the outer surface of the RO Membrane Element and the inner wall of the Pressure Vessel. The air pocket would allow the RO Membrane Element to expand outward during operation, causing irreversible mechanical damage to the RO Membrane Element that results in higher than normal Product Water Flow and High Product Water Salinity.
 - d. Product Water line is blocked. NEVER Block the Product Water Line. NEVER place a valve in the Product Water Line that can close and block the Product Water Line. Blockage of the Product Water line will result in high pressure build up of 950 PSI (66 BAR) within the line and within the product water tube and product water channel of the RO Membrane Element. If the System is shut down while the Product Water Line is blocked, irreversible damage to the RO Membrane Element will occur.
 - e. Chemical attack, one that will dissolve the membrane surface such as an oxidant like Chlorine, has destroyed the RO Membrane Element surface.

b. Solutions:

- a. Replace the O-Ring if wear or damage is present.
- b. Replace the End Plug if it is damaged or cracked.
- c. Replace the RO Membrane Element. NEVER place two Brine Seals on one RO Membrane Element.
- d. Determine what blocked the Product Water Line and correct the condition. Replace the RO Membrane Element.
- e. Determine the source and correct the situation. Replace the RO Membrane Element.

2. Problem: Product Water Flow slowly, over months, decreases and Product Water Salinity, slowly over months, increases, quality decreases:

a. Descriptions:

- a. As the System is exposed to sea water, biological matter will eventually coat the membrane surface, causing a drop in production, loss of product water flow accompanied by an increase in salt passage in the product water. Fresh Water Rinsing will minimize and slow down the biological fouling that naturally occurs. Chemical Cleaning at appropriate intervals will remove the biological fouling and extend the life of the RO Membrane Element.
- b. As the RO Membrane Element is operated, dissolved solids, salts or mineral, will build up on the membrane surface ,causing a drop in production and loss of product water flow accompanied by an increased percentage of dissolved solids, salt, in the product water. Chemical cleaning at appropriate intervals will dissolve the salt and mineral fouling and extend the life of the RO Membrane Element.

b. Solution: Clean or replace the RO Membrane Element.

3. Problem: Product Water Flow suddenly decreases and Product Water Salinity, suddenly increases, quality decreases.

- a. Description: Chemical and oil attacks will cause production to suddenly decrease and product water quality to worsen.
- b. Solution: Replace the RO Membrane Element(s) if they have been attacked by chemicals or oil.

1. Problem: Feed Water leaks from the Pressure Vessel.

a. Descriptions:

- a. The High Pressure fittings entering the Pressure Vessel are O-Ring sealed at the End Plug that they attach to. Should a leak develop at a High Pressure Fitting inspect the respective O-Ring for signs of wear or damage.
- b. The End Plugs seal against the inner surface of the High Pressure Vessel. The O-Ring that creates this seal is the “Brine O-Ring.” Should a leak develop between the End Plug and the inside wall of the Pressure

Vessel, remove the end plug and inspect the Brine O-Rings for wear or damage. Replace them if wear or damage is present.

- b. Solution: Replace the O-Ring if wear or damage is present.

Automated Motor-Actuated Back Pressure Regulator

Prior to assuming that the Back Pressure Regulator's Electric Motor Actuator has failed, perform a Function Test.

1. **Problem: The Operating Pressure is higher than normal when the System is operated in the Automatic mode.**
 - a. Description: When the System Feed Water is higher than normal in salinity and/or lower than normal in temperature, the operating pressure will automatically increase in an attempt to produce the specified amount of Product Water. Pressure will increase until the Product Water flow is achieved or until the operating pressure reaches 950 PSI (66 BAR).
 - b. Solution: The System is programmed to not exceed 950 PSI (66 BAR) operating pressure. No correction is necessary.
2. **Problem: The Operating Pressure is lower than normal when the System is operated in the Automatic mode.**
 - a. Description: The Product Water Flow reading at the Touch Pad indicates that the System is producing the specified amount of Product Water. However, the Operating Pressure is lower than normal. When the System Feed Water is lower than normal in salinity and/or higher than normal in temperature the operating pressure will automatically decrease to not exceed the specified amount of product water. Pressure will decrease until the specified product water flow is achieved.
 - b. Solution: The System is programmed to not exceed the specified amount of Product Water Flow. No correction is necessary.
3. **Problem: The Operating Pressure does not increase when the System is operated or does not decrease when the System is stopped when operated in the Automatic Mode.**
 - a. Description: The Back Pressure Regulator Valve is controlled by a gear motor arrangement. The Valve is coupled to the gear shaft with a female coupler. The set screws holding the gear shaft or Valve shaft to the coupler may have become loose. The gear shaft is turning but the valve shaft is not. When the System Feed Water is lower than normal in salinity and/or higher than normal in temperature the operating pressure will automatically decrease to not exceed the specified amount of product water. Pressure will decrease until the specified product water flow is achieved.
 - b. Solution: Tighten the set screws to secure the gear shaft and valve shaft to the coupler if they are loose.
4. **Problem: The gear shaft does not rotate at all.**
 - a. Description: The Electric Motor and or gear assembly may not be functioning.
 - b. Solution: Repair or replace the Back Pressure Regulator.

Brine Discharge Flow Meter

Prior to assuming that the Brine Discharge Water Flow Meter has failed, check the Control Logic model setup.

1. **Problem: The Brine Flow Meter does not register the proper Brine Water Flow at the Touch Pad.**
 - a. Descriptions:
 - a. Debris may be trapped within the flow meter body, causing false readings.
 - b. There may be a water substantial leak prior to the Brine Flow Meter, resulting in a lower than normal reading.

-
- c. Feed Water may be exiting the Product Water Line, resulting in lower than normal Brine Water Flow. Abnormalities that would allow Feed Water to bypass into the Product Water Line include the following: the RO Membrane Element is not installed; the RO Membrane Element is damaged allowing brine water to mix with product water; a damaged O-Ring or cracked End Plug is allowing brine water to mix with product water. All of these abnormalities result in higher than normal Product Water Flow reading and lower than normal Brine Flow reading.
- b. Solutions:
 - a. Remove the Flow Meter from the System. Using a water hose, force water into the outlet of the flow meter to dislodge any trapped debris. You may also replace the Flow Meter.
 - b. Correct and repair any water leaks.
 - c. Ensure that the RO Membrane Element(s) are installed. Replace a damaged RO Membrane Element, Product Water O-Rings or End Plugs.

2. Problem: The Brine Flow Meter does not register any flow at all at the Touch Pad.

- a. Description: There may be a loose wire, loose connection, broken wire or damaged Flow Meter.
- b. Solution: Check all wiring and plug connections. Replace the Flow Meter if determined to be non-functional.

Salinity Probe

The Salinity Probe electronically measures, with temperature compensation, the salinity content of the Product Water. The Salinity Probe is calibrated at the factory to 800 PPM TDS NaCl at 77°F (25°C). Although the Salinity Probe is temperature compensated, it is not 100% linear across the full range that it must measure. The full range of salinity that the probe must attempt to measure is from 5 to 2000 PPM at 34°F to 122°F (1°F to 50°Celsius). Always reference the probe accuracy and calibration to 800 PPM TDS NaCl at 77°F (25°C).

1. **Problem: Debris or biological growth can cause the Salinity Probe to give incorrect measurement of the Product Water Salinity.**
 - a. Solution: Clean the Salinity Probe contact pins annually or at any sign of incorrect reading.
2. **Problem: The Salinity Probe may have drifted from it's original calibration point.**
 - a. Solution: Replace the Salinity Probe.

SYSTEM MAIN CONTROLLER UPDATE AS OF 10/30/2017

System Fault Error Messages

The Aquamatic, Aquamatic XL and AquaWhisper DX control system contains fault log message center. During operation, if a dangerous condition exists, or a critical monitoring component fails which would result in the control systems inability to accurately detect a dangerous condition. The detected condition or failure is deemed as a ‘Critical Error’. These types of faults result in a rapid shutdown of the water maker and all associated equipment. The fault log message center is the information window used by the operator to examine system faults or failures.

When these operational faults or equipment failure happens, the controller will automatically switch the display screen to the following information window:

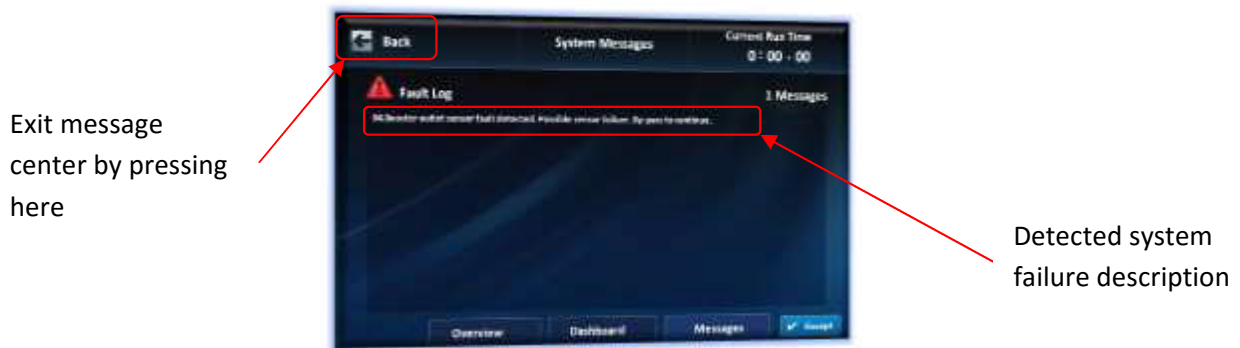

1. To stop the alarm press, Accept.

System Alarm codes and likely causes

Number	Alarm Displayed	Likely Causes
01	Automatic start requested with system locked in E-Stop. Please clear E-Stop.	The E-Stop button was pressed in when an automatic start was requested. Release the E-stop button before continuing.
02	System emergency stop requested in automatic mode. All moving machinery stopped.	The E-Stop button was pressed while the system was running. Release the E-stop button before attempting to run the unit again.
03	Automatic start requested with booster pump running in manual mode.	The booster pump was running in manually mode, and the operator requested starting the system in automatic mode. Stop the booster pump in manual control screen before re-attempt to start the system in automatic mode.

04	Booster outlet sensor fault detected. Possible sensor failure. By-pass to continue.	The booster pump outlet pressure transducer sensor is not reporting values as expected. The transducer could be unplugged, a wiring fault may exist, or the sensor itself may have failed. The fault must be fixed and cleared before running the system again. If an emergency exists the system can still be run by activating the sensor by-pass function. Please contact your dealer for help.
05	HP pump inlet sensor fault detected. Possible sensor failure. By-pass to continue.	The high-pressure pump inlet pressure sensor is not reporting values as expected. The transducer could be unplugged, a wiring fault may exist, or the sensor itself may have failed. The fault must be fixed and cleared before running the system again. If an emergency exists the system can still be run for a limited time by activating the sensor by-pass function. Please contact your dealer for help.
06	HP pump outlet sensor fault detected. Possible sensor failure. By-pass to continue.	The high-pressure pump inlet pressure sensor is not reporting values as expected. The transducer could be unplugged, a wiring fault may exist, or the sensor itself may have failed. The fault must be fixed and cleared before running the system again. If an emergency exists the system can still be run for a limited time by activating the sensor by-pass function. Please contact your dealer for help.
09	Salinity sensor fault detected. Possible sensor failure. Only manual mode permitted.	The salinity sensor temperature function is no longer readable by the control system, this is usually an indication of water penetration into the sensor itself causing failure. The system will default to manual mode only if salinity readings are still available. The user can divert potable water into the ships storage tank, but if salinity readings are not available, the user must bypass this sensor to gain access to potable water diversion functions. Please contact your dealer for help.
10	Product flow sensor fault detected. Possible sensor failure. By-pass to continue.	The product water flow meter is no longer sending reading to the controller. The sensor could be unplugged, a wiring fault may exist, or the sensor itself may have failed. Automatic operation is not available. The sensor must be fixed or replaced before Automatic mode is available. If an emergency exists, the system can still be run in automatic mode by activating the sensor by-pass function. Please contact your dealer for help.

11	Brine flow sensor fault detected. Possible sensor failure. By-pass to continue.	The brine water flow meter is no longer sending signals into the controller. The sensor could be unplugged, a wiring fault may exist, or the sensor itself may have failed. Automatic operation is not available. The sensor must be fixed or replaced before Automatic mode is available. If an emergency exists, the system can still be run in automatic mode by activating the sensor by-pass function. Please contact your dealer for help.
12	High pressure pump inlet pressure low. Please check filtration for high fouling.	Inlet pressure to the high-pressure pump fell below minimum allowable set-points. This is usually attributed to booster pump cavitation (air in the feed line), a filter is clogged, or a large system leak. Check your system for leaks, and check feed lines for possible air vacuum leak. If none of these conditions exist, change your filtration elements and attempt to re-start the system again.
13	High pressure pump inlet pressure high. Pump damage can occur if started.	Inlet pressure to the high-pressure pump is above maximum allowable set-points. This is usually attributed to feed line over pressurization, check your incoming feed water line for malfunction of any boosting devices installed, and finally check rotation direction of the high pressure pump itself. If incorrect rotation is present this can cause over pressurization of the feed line. Lastly check that any high-pressure check valves installed are functioning correctly.
14	HP pump inlet sensor in by-pass & HP pump outlet pressure low. Possible cavitation	The system was operating with the high-pressure pump inlet sensor in bypass mode. During operation, the high-pressure pump achieved minimum allowable outlet pressure, but then outlet pressure dropped below the low set point. This is a good indication to the controller that pump cavitation was occurring. The system was stopped to protect the pump from damage. Follow the items listed in fault description 12 above, to locate the possible reason for this pump inlet cavitation.
15	HP pump inlet sensor & HP pump outlet sensor in by-pass. Operation not possible.	The user has requested that both the inlet pressure transducer and outlet pressure transducer of the high-pressure pump be set into bypass. Requests for this state are usually not permitted by the bypass screen manager. However, if for some reason these settings have been allowed, the unit will fail an automatic startup attempt as with both sensors bypassed, it is impossible to apply any protective measures to ensure high pressure pump failsafe operation. Deactivate one of these sensor bypasses to continue. If both sensors are malfunctioning, the unit cannot be run until at least one sensor is fixed or replaced.

16	HP pump outlet exceeded maximum permissible pressure. System stopped.	During normal operation, in manual and automatic mode, the system exceeding maximum pressure allowed. A fault has occurred and the system will activate an emergency shutdown to protect the water maker and ship equipment. Re-start the system, if back pressure regulator initialization completes correctly and the system re-starts; its highly possible a rapid change in system pressure occurred for some unknown external reason and the change was so rapid that the automatic pressure regulator was not able to adjust quickly enough to compensate. If this happen during system commissioning check BPR wiring.
17	HP pump outlet sensor in by-pass & brine flow low. Possible cavitation.	The system was operating with the high-pressure pump outlet sensor in bypass mode. During operation, the control system detected that brine flow dropped below calculated levels. This is a good indication that pump cavitation was occurring. The system was stopped to protect the pump from damage. Follow the items listed in fault description 12 on previous page, to locate the possible reason for this pump inlet cavitation.
18	BPR initialization fault. BPR is jammed. Please attempt recovery in 'Customer Options'.	The control system attempted to initialize the automatic back pressure regulator assembly, during this initialization a motor over current was detected. This indicates the pressure regulator is jammed, follow the instructions listed in section 15 to attempt to free up the regulator. If these steps do not release the regulator removal of the system top cover and manual intervention with a wrench may be required.
19	System emergency stop requested in manual. All moving machinery stopped!	Once the system was running in manual mode the E-Stop button was pressed. Release the E-stop button before attempting to run the unit again.
20	Brine flow low during manual operation. Possible pump cavitation.	The system was operating with the high-pressure pump outlet sensor in bypass mode. During operation, the control system detected that brine flow dropped below calculated levels. This is a good indication that pump cavitation was occurring. The system was stopped to protect the pump from damage. Follow the items listed in fault description 12 on previous page, to locate the reason for this pump inlet cavitation.
21	Brine flow low during fresh water flush. Possible loss of feed supply.	The system was fresh water flushing the unit, but detected that brine water flow rates are much lower than expected. This usually indicates a loss of fresh water supply to the unit. Please check this water supply to ensure it is not isolated elsewhere in the ship. If fresh water is present, check correct operation of the fresh water flush valve.

22	Operation requested in feed water warmer than system temperature specifications.	The user requested system operation, but the feed water is hotter than permitted for accurate system operation. The system salinity sensor is calibrated to read salinity accurately in water up to 40C. Water above this temperature will yield unknown results and as such, the control system will not allow operation in these waters.
23	Operation requested in feed water colder than system temperature specifications.	The user requested system operation, but the feed water is colder than permitted for accurate system operation. The system salinity sensor is calibrated to read salinity accurately in water down to 5C. Water below this temperature will yield unknown results and could freeze once purified by the system RO membranes and as such, the control system will not allow operation in these waters.
24	Maximum emergency operation time expired. Please contact Parker for assistance.	The system has been operating with a critical sensor in bypass mode for the maximum allowable time. The unit will no longer operate until this fault is repaired. In emergencies, it is possible to reset the by-pass operation timer. Please contact Parker further help
25	Operator did not increase system pressure within allowed time.	The system was started in either manual mode or the system is an AquaWhisper DX. Once the HP pump is activated, the user has a finite time in which to adjust system pressure to above minimum (>250PSI), if this step is not taken, the system automatically shuts down and generates this message.
26	BPR drive current exceeded. BPR is jammed	During operation of the system BPR, the current required to turn the unit exceeded the allowable maximum. This indicates to the controller that the BPR is jammed, or the motor has failed and has an internal short circuit. If the BPR is not jammed and moves freely, Contact Parker for further assistance
27	BPR jam occurred while opening valve. Auto release will be attempted once alarm is accepted.	While operating the BPR valve in a clockwise direction, the valve current rose exponentially, indicating the valve has reached a fully closed position, when this message is accepted by the user, the control system will use all available motor power to release the valve from this jammed position.
28	BPR jam occurred while closing valve. Auto release will be attempted once alarm is accepted.	While operating the BPR valve in a counterclockwise direction, the valve current rose exponentially, indicating the valve has reached a fully open position, when this message is accepted by the user, the control system will use all available motor power to release the valve from this jammed position.

System Warning Messages

The Aquamatic, Aquamatic XL and AquaWhisper DX control system contains a system warning message center. These types of faults are meant to bring attention to the user that the system is not running normally. These faults are ok for a short term, but may lead to a larger problem if not corrected. When a system performance related issue is detected the system alarm output will sound and a warning will be logged in the warning message center.

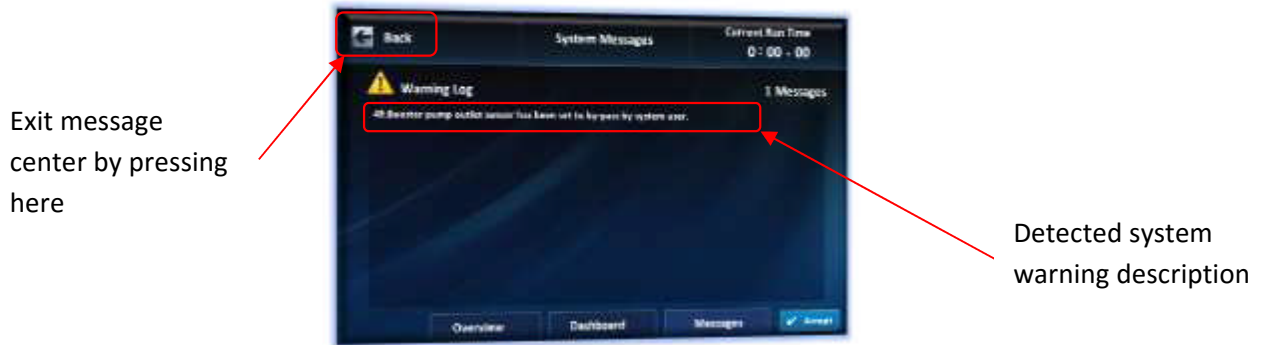

1. To stop the alarm press, Accept.

System warning notifications and likely causes

Number	Message Displayed	Possible Causes
49	Booster pump outlet sensor has been set to by-pass by system user.	The operator has entered the emergency override screen and activated the emergency by-pass of the booster pump outlet pressure sensor. The system can only operate in this state for a limited time. Consult Parker for additional information
50	HP pump inlet sensor has been set to by-pass by system user.	The operator has entered the emergency override screen and activated the emergency by-pass of the high-pressure pump inlet pressure sensor. The system can only operate in this state for a limited time. Consult Parker for additional information
51	HP pump outlet sensor has been set to by-pass by system user. Manual operation only.	The operator has entered the emergency override screen and activated the emergency by-pass of the high-pressure pump outlet pressure sensor. The system can only operate in this state for a limited time. Consult Parker for additional information.

53	Product water salinity sensor has been set to by-pass by user. Manual operation only.	The operator has entered the emergency override screen and activated the emergency by-pass of the system salinity sensor. Manual operation of the unit is still possible. However, operation of the product diversion valve will need to be carried out manually.
54	Product flow sensor has been set to by-pass by user. Manual operation only.	The operator has entered the emergency override screen and activated the emergency by-pass of the system product flow sensor. The system can still function in this mode but only for a limited time. Consult Parker for additional information.
55	Brine flow sensor has been set to by-pass by user.	The operator has entered the emergency override screen and activated the emergency by-pass of the system brine flow sensor. The system can still function in this mode but only for a limited time. Consult Parker for additional information.
56	HP pump inlet pressure sensor in by-pass. Emergency operation mode active.	The operator has activated the emergency by-pass of the HP Pump inlet pressure sensor, and is now operating the system. Operation can continue until the maximum preset time has elapsed (50hrs). Contact Parker for additional information
57	HP pump outlet pressure sensor in by-pass. Emergency operation mode active	The operator has activated the emergency by-pass of the HP Pump outlet pressure sensor, and is now operating the system. Operation can continue until the maximum preset time has elapsed (50hrs). Contact Parker for additional information
58	Salinity probe 'In Air'. System automatic controls changed to manual mode only.	The salinity probe is reporting values only seen when the probe element is not submerged in water, this can happen when the system has been dormant for extended periods of time. In these eventualities, running the system in manual mode is possible. Once the probe senses water this mode will automatically be turned off. On the next automatic start up, automatic mode will be used.
59	System at maximum operating pressure but product flow rates are lower than expected.	The system has reached maximum operating pressure; however, the expected production flow has not been achieved. This could be the result of bad quality feed water, very cold feed water, or a clogging of the system membranes. The system will continue to operate in this way until turned off, or until the condition is fixed (warmer feed water, better quality feed water, etc).
60	Extended delay in production of potable water. Check settings & feed water quality.	The system is running in automatic mode, but has not been able to produce potable water within the normal time frames. Check system pressure settings, if needed, verify system feed water is within normal specifications.

61	Product water quality lost. Possible feed water quality issue. Attempting to rectify.	The system is running in automatic mode and was producing potable water, but for some unknown reason the water quality of the product water deteriorated and is no longer acceptable. Check system pressure settings
62	High pressure pump hours high. Mechanical inspection of pump recommended.	The high-pressure pump has run for more than the recommended maximum number of hours between services, and now requires inspection. This detailed service is highly recommended to extend the life of your unit
63	High pressure pump oil hours high. Pump oil replacement recommended.	The high-pressure pump has run for more than the recommended number of hours between oil inspections, and now requires this inspection or possible oil change. This quick service is highly recommended to extend the life of your unit.
64	Brine flow sensor in by-pass mode. Emergency operation mode active.	The operator has activated the emergency by-pass of the system brine flow sensor, and is now operating the system. Operation can continue until the maximum preset time has elapsed (50hrs). Contact Parker for additional information
65	Tank level control detected product tank full. System will restart when tank is low.	The vessel potable water storage tank reports being full, and the system has been stopped to avoid overflowing of this tank. Once the tank reports low levels the system will re-start automatically, providing the user has not operated the system and power to the system has not been disconnected.
66	System HP pump output below minimum. Please increase system pressure using BPR	The system was started in either manual mode or the system is an AquaWhisper DX. Once the HP pump is activated, the user has a finite time in which to adjust system pressure to above minimum (>250PSI), if this step is not taken within 60 seconds of pump activation, the system automatically generates this message. If the pressure is not increased above minimum with a 10-minute period, the control system will shut the water maker down

Chapter 9

Glossary

Terms

Cascading Failure

A failure in a system of interconnected parts in which the failure of a part can trigger the failure of successive parts.

Boundary Layer

(Also known as Concentration Polarization.) When water permeates through the membrane, nearly all the salt is left behind in the brine channel. In any dynamic hydraulic system, the fluid adjacent to the wall of the vessel is moving relatively slow. Even though the main body of the stream is turbulent, a thin film adjacent to the wall (membrane) is laminar. This thin film is called the boundary layer. At the boundary layer the salts are saturated and can readily adhere to and pack into the RO membrane element surface if the Feed Water Flow is insufficient. For this reason, it is important to maintain sufficient Feed Water flow, to prevent Concentration Polarization, through the RO membrane element.

Brine Velocity

The brine flow over the membrane surface is very important to both product water quality and quantity. At low flows, concentration polarization occurs, causing the water quality to decline. In addition to inferior product water quality, low brine flows can increase the precipitation of sparingly soluble salts which will foul the RO membrane element surface (concentration polarization). If this occurs, the product water flux (production) will decline. The Feed Pump integrated design provide a relatively smooth and continual flow of Feed Water across and through the RO membrane element.

Compaction

Some densification of the membrane structure may take place while operating at elevated pressures, above 1000 PSI. The change is known as compaction and is accompanied by a reduction in the water permeation rate. When the RO membrane element is subjected to elevated pressures beyond 1000 PSI the Product Water Channel becomes squeezed which results in restriction and in turn product water recovery reduction.

Osmotic Pressure

The transfer of the water from one side of the membrane to the other will continue until the head (pressure) is great enough to prevent any net transfer of the solvent (water) to the more concentrated (feed water) solution. At equilibrium, the quantity of water passing in either direction is equal, and the head pressure is then defined as the "Osmotic Pressure" of the solution having that particular concentration of dissolved solids.

Pressure

The operating pressure has a direct affect on product water quality and quantity. Both factors will increase as the system pressure increases (higher quantity and higher quality within design limits). The system must be operated at the lowest pressure required to achieve the designed product water flow rate. This parameter also minimizes compaction, which proceeds at a faster rate at higher pressures as well as at higher temperatures. The System self adjusts its operating pressure to maintain a precise amount of Product Water Flow. However in so doing, at low temperatures and or high salinity feed water conditions the system will operate at higher than normal pressure in maintaining the specified amount of product water flow. This is normal, to be expected, and is due to the design characteristics of the system.

Spiral-Wound Membrane

The spiral-wound membrane consists of multiple membrane envelopes each formed by enclosing a channelized product water carrying material between two large flat membrane sheets. The membrane envelope is sealed on three edges with a special adhesive and attached with the adhesive to a small diameter pipe. A polypropylene screen is used to form

the feed water channel between the membrane envelopes. A wrap is applied to the membrane element to maintain the cylindrical configuration. The center tube is also the permeate (product water) collecting channel. Several elements may be connected in series within a single or multiple pressure vessels).

Water Temperature Effect

The product water flow through the membrane is significantly affected by the water temperature. At any given pressure this flow increases with increasing water temperature and is reduced at lower temperatures. The System over comes this factor by self adjusting the operating pressure to maintain a precise amount of Product Water Flow.

Chapter 10

Appendix



CERTIFICATE NUMBER
16-HS1474584-PDA

DATE
18 Feb 2016

ABS TECHNICAL OFFICE
Houston SED Machinery - Piping
& Electrical Sys.

CERTIFICATE OF DESIGN ASSESSMENT

This is to certify that a representative of this Bureau did, at the request of

PARKER WATER PURIFICATION

assess design plans and data for the below listed product. This assessment is a representation by the Bureau as to the degree of compliance the design exhibits with applicable sections of the Rules. This assessment does not waive unit certification or classification procedures required by ABS Rules for products to be installed in ABS classed vessels or facilities. This certificate, by itself, does not reflect that the product is Type Approved. The scope and limitations of this assessment are detailed on the pages attached to this certificate.

Product: **Desalinator, Reverse Osmosis**

Model: **Aqua Matic**

This Product Design Assessment (PDA) Certificate 16-HS1474584-PDA, dated 18/Feb/2016 remains valid until 17/Feb/2021 or until the Rules or specifications used in the assessment are revised (whichever occurs first).

This PDA is intended for a product to be installed on an ABS classed vessel, MODU or facility which is in existence or under contract for construction on the date of the ABS Rules or specifications used to evaluate the Product.

Use of the Product on an ABS classed vessel, MODU or facility which is contracted after the validity date of the ABS Rules and specifications used to evaluate the Product, will require re-evaluation of the PDA.

Use of the Product for non ABS classed vessels, MODUs or facilities is to be to an agreement between the manufacturer and intended client.

AMERICAN BUREAU OF SHIPPING

Tim Kimble
Engineer/Consultant

NOTE: This certificate evidences compliance with one or more of the Rules, Guides, standards or other criteria of ABS or a statutory, industrial or manufacturer's standards. It is issued solely for the use of ABS, its committees, its clients or other authorized entities. Any significant changes to the aforementioned product without approval from ABS will result in this certificate becoming null and void. This certificate is governed by the terms and conditions as contained in ABS Rules 1-1-A3/9 9 Terms and Conditions of the Request for Product Type Approval and Agreement (2010)



CERTIFICATE NUMBER: LA2004823- X

PORT OFFICE: Los Angeles, CA

Certificate of MANUFACTURING ASSESSMENT

This is to certify that: The Undersigned did evaluate the relevant manufacturing quality procedures for the type of products of the manufacturer:

Parker Hannifin Corporation
Filtration Group / Water Purification Plant at Carson CA

The methods of assuring and controlling quality during production as required by the ABS Rules or Guides for the product and the associated specifications or standard were verified to reflect the specific surveys, required by the Rules and Standards for the manufacture of:

Oil Filtering Equipment

The manufacturer presented a sample or specimen of the product, representative of the "type" approved, to the undersigned, for the purpose of verifying that the "type" has been manufactured in conformance with the Manufacturer's Product Design Assessments.

This Certificate of Manufacturing Assessment is an evaluation of the manufacturer alone and is neither an approval nor a rejection of the product described above. Unless cancelled, expired or revoked, this certificate remains valid subject to annual audits

Consult the ABS Type Approval website to confirm the continued validity of this certificate and the status of the particular products being manufactured.

ISSUE DATE 24 November 2014 EXPIRATION DATE 23 November 2019

SURVEYOR _____ 

FIRST ANNUAL ENDORSEMENT _____

SECOND ANNUAL ENDORSEMENT _____

THIRD ANNUAL ENDORSEMENT _____

FOURTH ANNUAL ENDORSEMENT _____

Note: This Certificate evidences compliance with one or more of the Rules, guides, standards or other criteria of American Bureau of Shipping and is issued solely for the use of the Bureau, its committees, its clients or other authorized entities. This Certificate is a representation only that the structure, item of material, equipment, machinery or any other item covered by this Certificate has met one or more of the Rules, guides, standards or other criteria of American Bureau of Shipping as of the date of issue. Parties are advised to review the Rules for the scope and conditions of classification and to review the survey records for a fuller description of any restrictions or limitation on the vessel's service or surveys. The validity, applicability and interpretation of this Certificate is governed by the Rules and standards of American Bureau of Shipping who shall remain the sole judge thereof. Nothing contained in this Certificate or in any notation made in contemplation of this Certificate shall be deemed to relieve any designer, builder, owner, manufacturer, seller, supplier, repairer, operator or other entity of any warranty express or implied.

Note: This Certificate evidences compliance with one or more of the Rules, guides, standards or other criteria of American Bureau of Shipping and is issued solely for the use of the Bureau, its committees, its clients or other authorized entities. This Certificate is a representation only that the structure, item of material, equipment, machinery or any other item covered by this Certificate has met one or more of the Rules, guides, standards or other criteria of American Bureau of Shipping as of the date of issue. Parties are advised to review the Rules for the scope and conditions of classification and to review the survey records for a fuller description of any restrictions or limitation on the vessel's service or surveys. The validity, applicability and interpretation of this Certificate is governed by the Rules and standards of American Bureau of Shipping who shall remain the sole judge thereof. Nothing contained in this Certificate or in any notation made in contemplation of this Certificate shall be deemed to relieve any designer, builder, owner, manufacturer, seller, supplier, repairer, operator or other entity of any warranty express or implied.

Declaration of Conformity

CE

SEA RECOVERY declares that the following models conform to the EN 55011A and EN 50082-2 standards:

Product Series:

Aqua Matic Series
Aqua Whisper Series
Aqua Whisper Mini Series
Ultra Whisper Series
Coral Sea Series

Model Names:

Aqua Matic
Aqua Whisper / DX
Aqua Whisper Mini
Ultra Whisper
Coral Sea



Manufacturer's Name:
Sea Recovery
Manufacturer's Address:
19610 South Rancho Way
Rancho Dominguez, CA 90220
U.S.A.



Official Seal

Supplementary Information:

"The product complies with the Requirements of the EMC Directive 89/336/EEC."

A handwritten signature in black ink that reads "Lisa Gomez".

Lisa Gomez
Quality & Environmental Manager
Manufacturer's Contact

MANAGEMENT SYSTEM CERTIFICATE

Certificate No:
113173-2012-AQ-USA-RvA

Initial certification date:
30 March, 2012

Valid:
19 March, 2015 - 19 March, 2018

This is to certify that the management system of

Parker Hannifin Corp. - Parker Water Purification

2630 East El Presidio Street, Carson, CA 90810 USA

has been found to conform to the Quality Management System standard:

ISO 9001:2008

This certificate is valid for the following scope:

Design and Manufacture of Water Purification Units

Place and date:
Katy, TX, 03 March, 2015

For the issuing office:
DNV GL – Business Assurance
1400 Ravello Drive, Katy, TX,
77449-5164, USA



The RvA is a signatory to the IAF MLA

A handwritten signature in black ink, appearing to read 'John C. Stefan'.

John C. Stefan
Management Representative

Single-Phase Electrical Motor Wiring

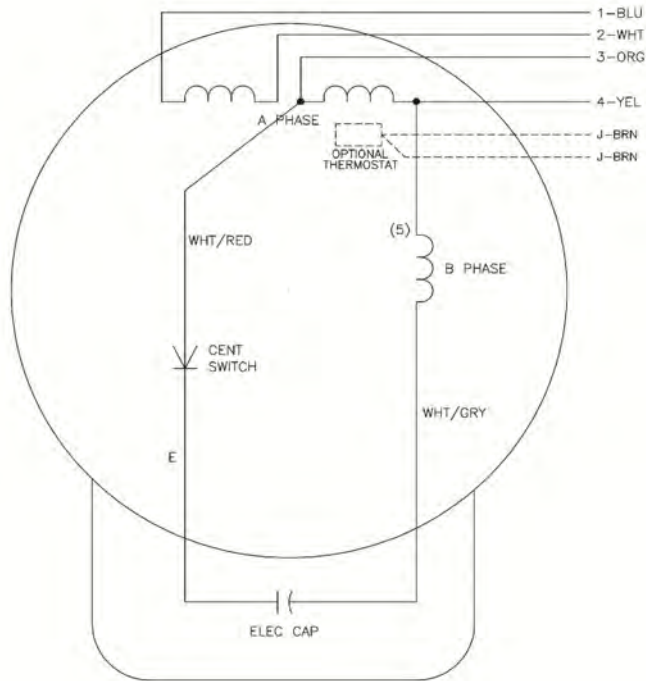

VOLTAGE	LINE A	LINE B	JOIN
220-230 VAC	1	4	2,3
110-115 VAC	1,3	2,4	-

NOTES:

1. CONNECTIONS ARE SHOWN FOR CCW ROTATION FACING END OPPOSITE SHAFT EXTENSION (STD). FOR CW ROTATION, INTERCHANGE 5 AND 8 INTERNALLY.
2. OPTIONAL THERMOSTAT IS PROVIDED WHEN SPECIFIED.
3. MULTIPLE CAPACITORS ARE CONNECTED IN PARALLEL UNLESS OTHERWISE SPECIFIED.
4. LEAD COLORS ARE OPTIONAL. LEADS MUST ALWAYS BE NUMBERED AS SHOWN.

Sea Recovery
 BOOSTER PUMP
 ELECTRIC MOTOR
 WINDINGS DIAGRAM CD0093
 SINGLE PHASE
 50/60 Hz
 110 - 115 VAC // 220 - 230 VAC
 RPM @ 50 Hz 2850 - @ 60 Hz 3450

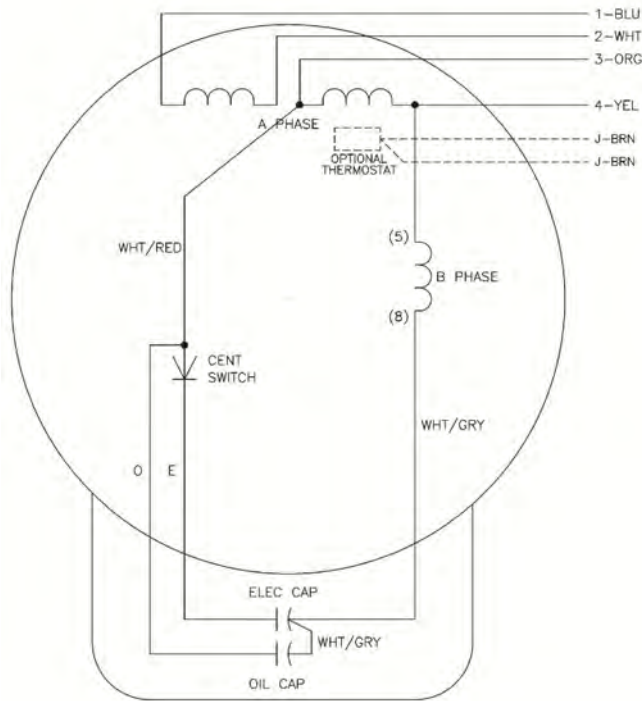

VOLTAGE	LINE A	LINE B	JOIN
220 - 230 VAC	1	4	2,3
110 - 115 VAC	1,3	2,4	-

NOTES:

1. CONNECTIONS ARE SHOWN FOR CCW ROTATION FACING END OPPOSITE SHAFT EXTENSION (STD). FOR CW ROTATION, INTERCHANGE 5 AND 8 INTERNALLY.
2. OPTIONAL THERMOSTAT IS PROVIDED WHEN SPECIFIED.
3. MULTIPLE CAPACITORS ARE CONNECTED IN PARALLEL UNLESS OTHERWISE SPECIFIED.
4. LEAD COLORS ARE OPTIONAL. LEADS MUST ALWAYS BE NUMBERED AS SHOWN.

Sea Recovery
 HIGH PRESSURE PUMP
 ELECTRIC MOTOR
 WINDINGS DIAGRAM CD0762
 SINGLE PHASE
 50/60 Hz
 110 - 115 VAC // 220 - 230 VAC
 RPM @ 50 Hz 2850 - @ 60 Hz 3450

Three-Phase Electrical Motor Wiring

ELECTRIC MOTOR WINDING / WIRING DIAGRAMS

THREE PHASE, 50/60 Hz, 220 - 230 VAC // 380 - 460 VAC

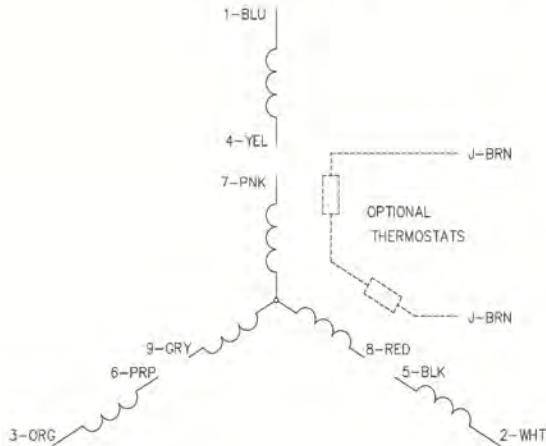

NOTES:

1. INTERCHANGE ANY TWO LINE LEADS TO REVERSE ROTATION.
2. OPTIONAL THERMOSTATS ARE PROVIDED WHEN SPECIFIED.
3. ACTUAL NUMBER OF INTERNAL PARALLEL CIRCUITS MAY BE A MULTIPLE OF THOSE SHOWN ABOVE.
4. LEAD COLORS ARE OPTIONAL. LEADS MUST ALWAYS BE NUMBERED AS SHOWN.

220 - 230 VAC
LOW VOLTAGE
(2Y)



LINE LEADS
220 - 230 VAC

380 - 460 VAC
HIGH VOLTAGE
(1Y)



LINE LEADS
380 - 460 VAC

Sea Recovery
BOOSTER PUMP
ELECTRIC MOTOR
WINDINGS DIAGRAM CD0005
THREE PHASE
50/60 Hz
220 - 230 VAC // 380 - 460 VAC
RPM @ 50 Hz 2850 - @ 60 Hz 3450

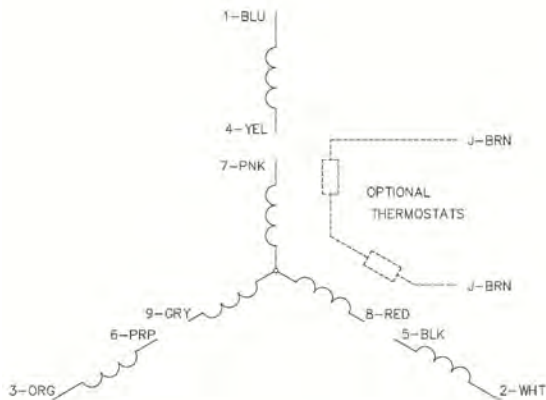

NOTES:

1. INTERCHANGE ANY TWO LINE LEADS TO REVERSE ROTATION.
2. OPTIONAL THERMOSTATS ARE PROVIDED WHEN SPECIFIED.
3. ACTUAL NUMBER OF INTERNAL PARALLEL CIRCUITS MAY BE A MULTIPLE OF THOSE SHOWN ABOVE.
4. LEAD COLORS ARE OPTIONAL. LEADS MUST ALWAYS BE NUMBERED AS SHOWN.

220 - 230 VAC
LOW VOLTAGE
(2Y)



LINE LEADS
220 - 230 VAC

380 - 460 VAC
HIGH VOLTAGE
(1Y)



LINE LEADS
380 - 460 VAC

Sea Recovery
HIGH PRESSURE PUMP
ELECTRIC MOTOR
WINDINGS DIAGRAM CD0005
THREE PHASE
50/60 Hz
220 - 230 VAC // 380 - 460 VAC
RPM @ 50 Hz 2850 - @ 60 Hz 3450

Three Phase Transformer Wiring

Three Phase Power Supplied to the Aqua Matic System
Step Down Transformer Primary and Secondary
(inside the System Control Box)
Wiring and Voltages

Three Phase Aqua Matic System Voltage
from 200 VAC to 208 VAC

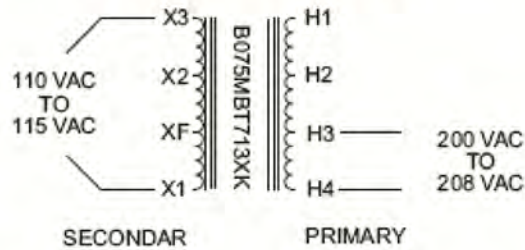

Three Phase Aqua Matic System Voltage
from 220 VAC to 240 VAC

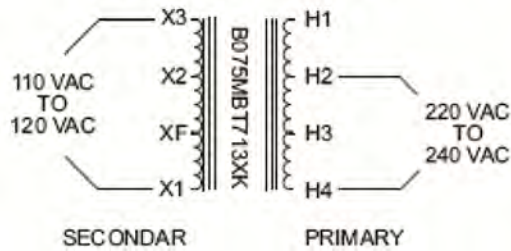

Three Phase Aqua Matic System Voltage
from 380 VAC to 480 VAC

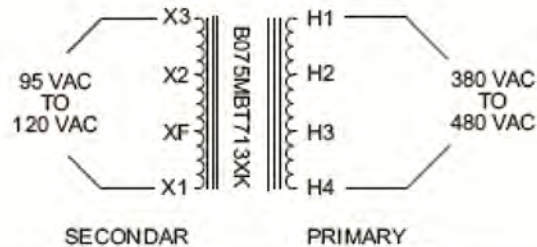

New System Initial Readings Form

NEW SYSTEM INITIAL READINGS

At the time of commissioning the NEW system, record the following information after one hour of continuous proper operation of the system.

Retain this form in this Owner's Manual for the owner and operator's future reference. This information is valuable to the servicing technicians in providing technical support to the owner and future operators of the AquaMatic. Provide this information to service technicians when requesting technical assistance.

Date Installed: _____ Date Commissioned: _____

Model Information:

System Serial Number: _____

Style: ___ Compact ___ Modular

R.O. Membrane/Vessel Assy Quantity: ___ 1 (one) ___ 2 (two)

System Capacity: ___ 450 GPD ___ 700 GPD ___ 900 GPD ___ 1400 GPD ___ 1800 GPD

Who Installed the System:

Company _____

Street Address _____

City, State _____

Country, postal code _____ Telephone _____

Name of Installer _____

Who Commissioned the System:

Company _____

Street Address _____

City, State _____

Country, postal code _____ Telephone _____

Name of Installer _____

System Power: _____ Volts AC _____ Hz _____ Phase

Feed Water Temperature: _____ Degrees Fahrenheit or _____ Degrees Celsius

Hour Meter Reading: _____ Hours

PRESSURE READINGS:

Low Pressure Transducer #1 _____ Psi or _____ kPa

Pressure Differential Pressure _____ psi or _____ kPa

Low Pressure Transducer #2 _____ psi or _____ kPa

High Pressure Transducer _____ psi or _____ kPa

WATER FLOW METER READINGS:

Flow Meter Product Water: _____ US Gallons Per Hour or _____ Liters Per Hour

Flow Meter Brine Discharge: _____ US Gallons Per Minute or _____ Liters Per Minute

WATER QUALITY:

Feed Water Salinity: _____ ppm or Location of use: _____

Product Water Salinity: _____ ppm

Problems, Unusual Occurrences, or Unusual Noises: _____

Daily System Readings

DAILY SYSTEM READINGS

Make Copies of this form and fill one in each time the System is operated. Record the following information after one hour of continuous proper operation of the system, or just prior to stopping the System.

Retain these forms in this Owner's Manual for future reference. This information is valuable to the servicing technicians in providing technical support of the Aqua Matic. Provide this information to service technicians when requesting technical assistance.

Date Installed: _____ Date Commissioned: _____

Model Information:

System Serial Number: _____

Style: ___ Compact ___ Modular

R.O. Membrane/Vessel Assy Quantity: ___ 1 (one) ___ 2 (two)

System Capacity: ___ 450 GPD ___ 700 GPD ___ 900 GPD ___ 1400 GPD ___ 1800 GPD

System Power: _____ Volts AC _____ Hz _____ Phase

Feed Water Temperature: _____ degrees Fahrenheit or _____ degrees Celsius

Hour Meter Reading: _____ Hours

PRESSURE READINGS:

Low Pressure Transducer #1 _____ psi or _____ kPa

Pressure Differential Pressure _____ psi or _____ kPa

Low Pressure Transducer #2 _____ psi or _____ kPa

High Pressure Transducer _____ psi or _____ kPa

WATER FLOW METER READINGS:

Flow Meter Product Water: _____ US Gallons Per Hour or _____ Liters Per Hour

Flow Meter Brine Discharge : _____ US Gallons Per Minute or _____ Liters Per Minute

WATER QUALITY:

Feed Water Salinity: _____ ppm or Location of use: _____

Product Water Salinity: _____ ppm

Problems, Unusual Occurrences, or Unusual Noises: _____

Chapter 11

Exploded Parts Views

Pre-Installation Matrix Drawings

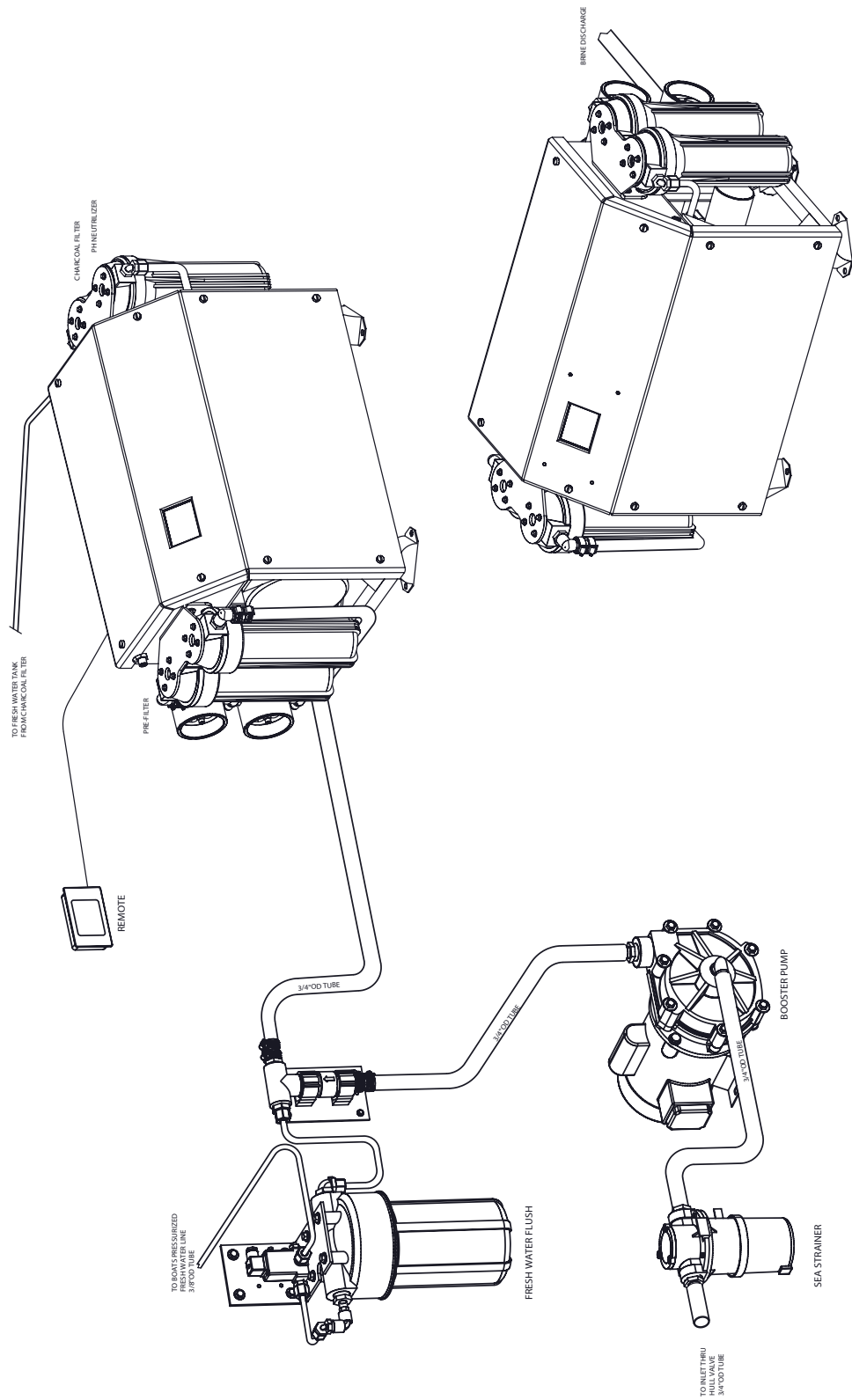

Figure 1: Standard Filter

Exploded Parts View

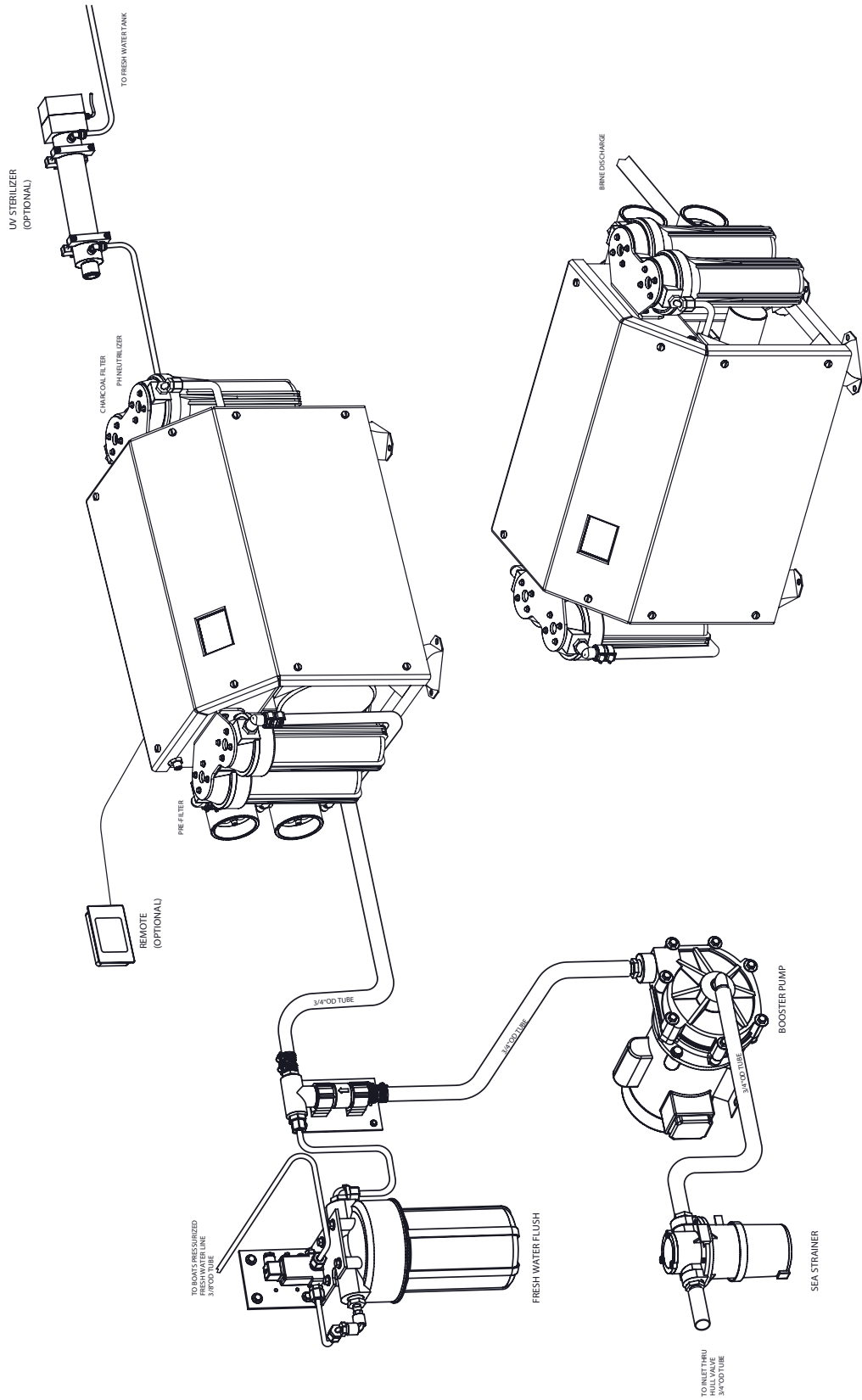

Figure 2: Standard Filter with UV Sterilizer

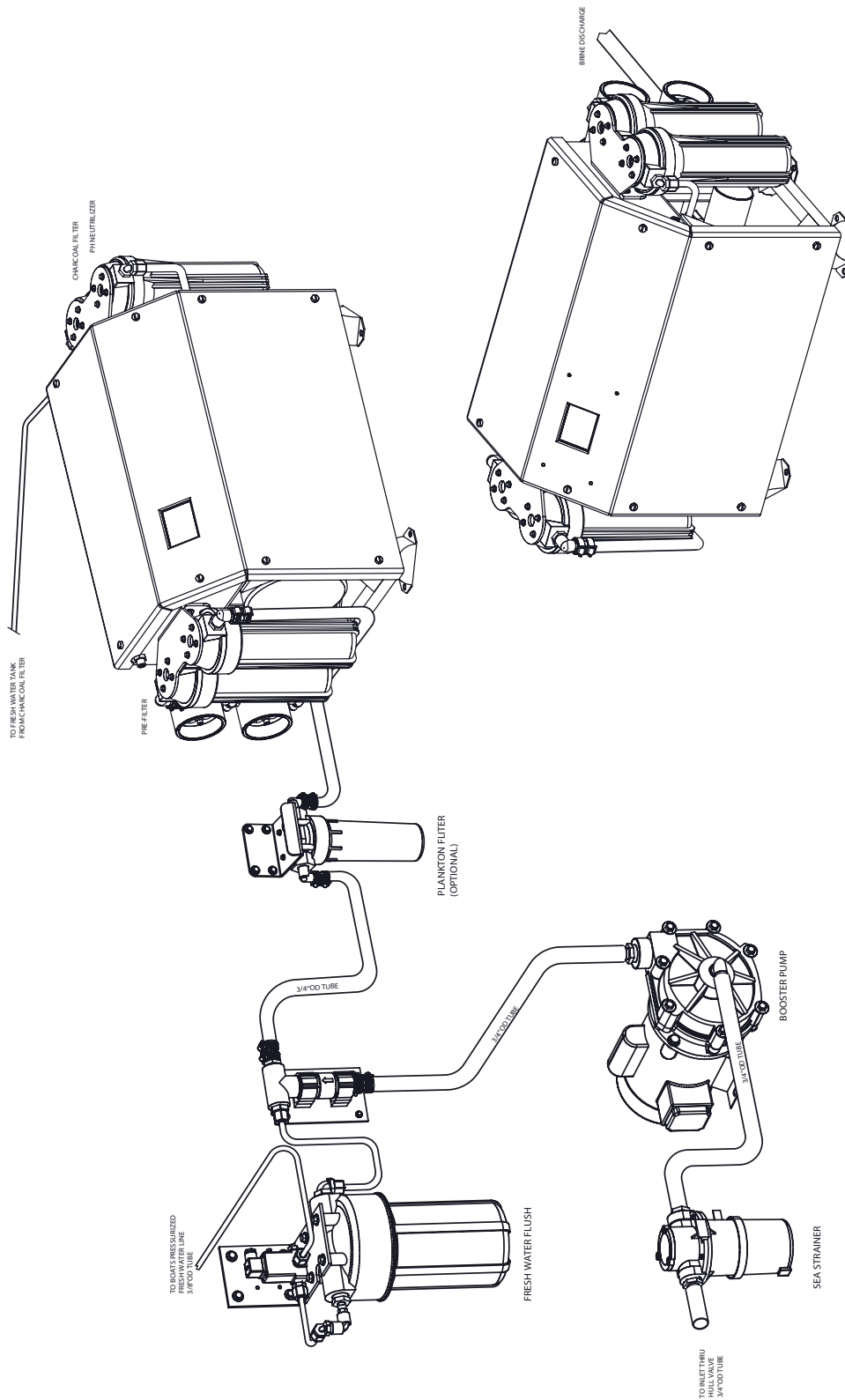

Figure 3: Standard Filter with Plankton Filter

Exploded Parts View

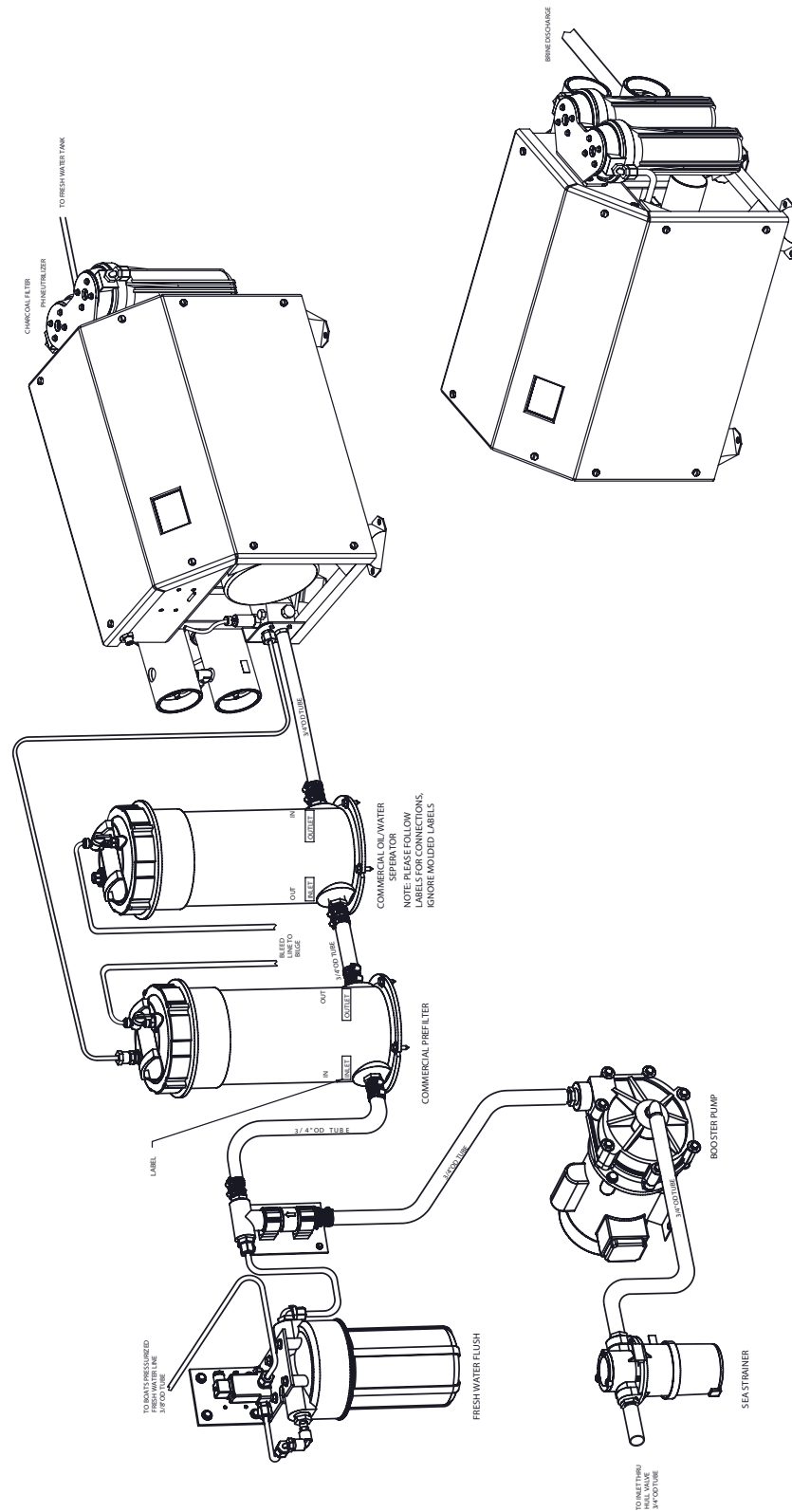

Figure 4: Commercial Pre-filter (CFP) with Oil/Water Separator (OWS)

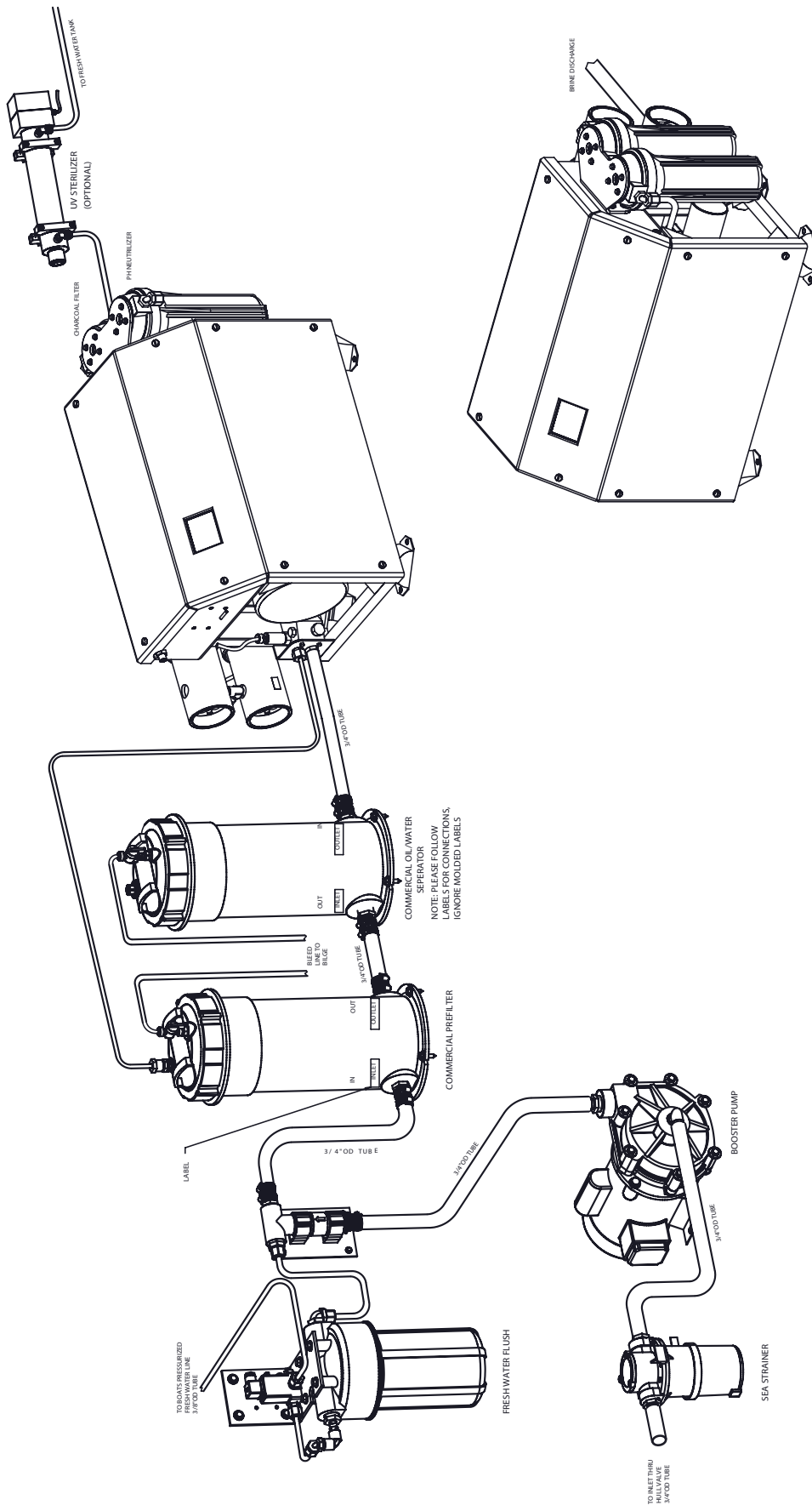

Figure 5: Commercial Pre-filter (CFP) with UV Sterilizer

Exploded Parts View

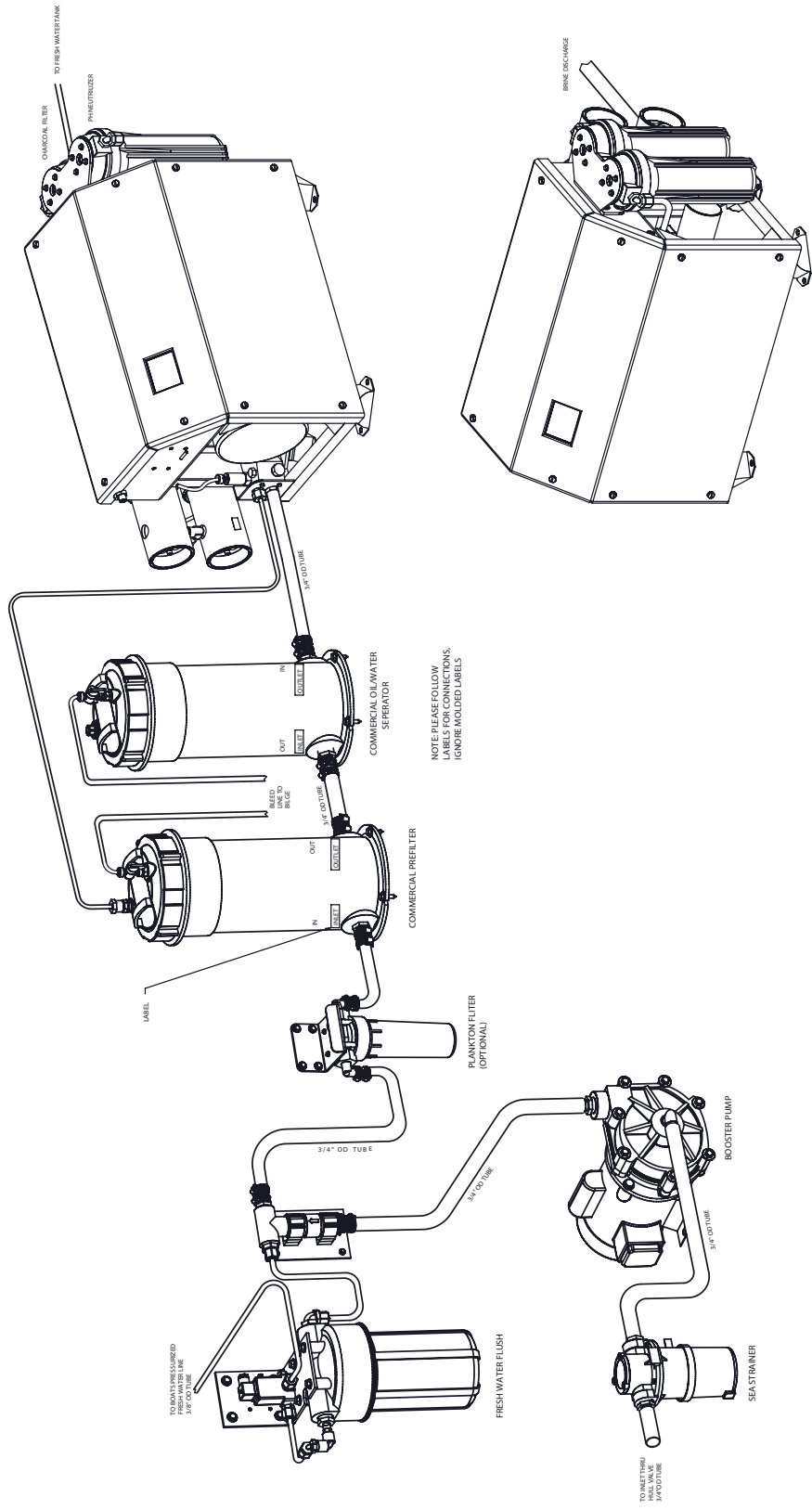
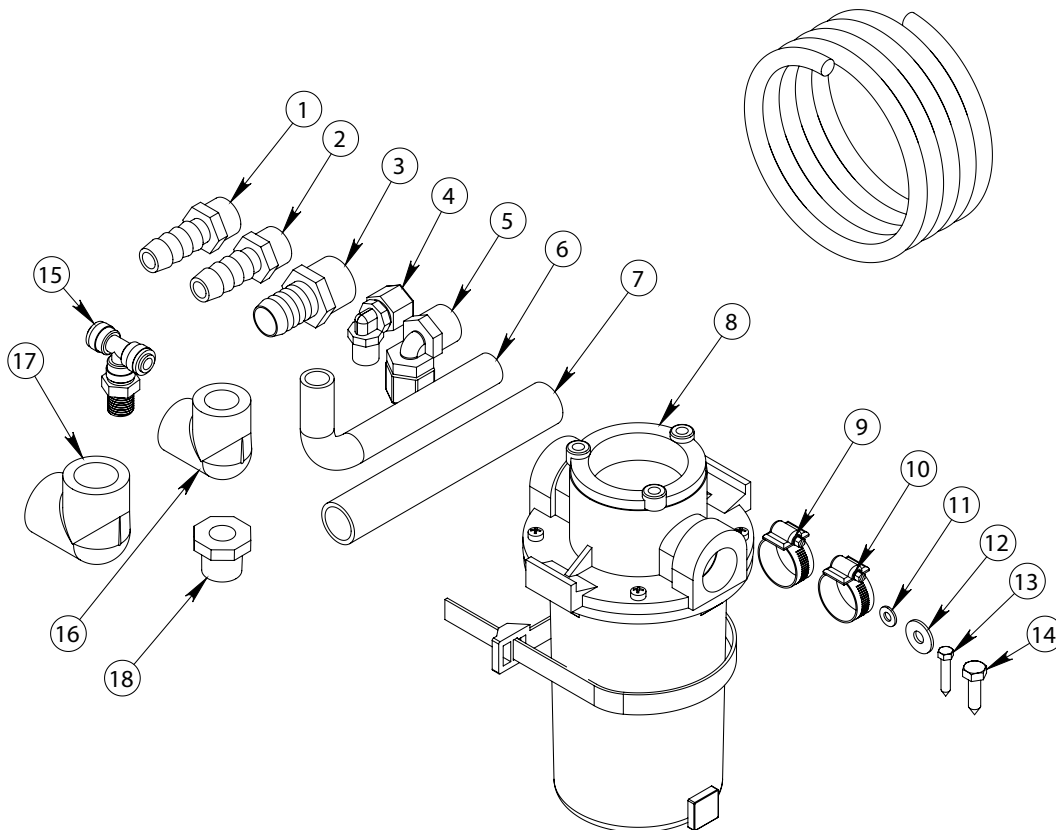

Figure 6: Commercial Pre-filter (CFP) with Plankton Filter

B001990001 INSTALLATION KIT AQUA SERIES UNITS

ITEM NO.	QTY.	PART NUMBER	DESCRIPTION
1	1	0112652500	ADAP 1/2 MNPT X 1/2 BARB NYLON
2	5	01126526DG	ADAP 1/2 MPT X 3/4 BARB NYLON
3	3	0112653700	ADAP 3/4 MPT X 3/4 BARB NYLON
4	3	0204020869	ELB90 1/4 TUBE X 1/4 MPT PLAST
5	1	0204021969	ELB90 3/8 TUBE X 1/2 MPT PLAST
6	20 ft.	0328065066	HOSE CLEAR BRAID 1/2 "
7	15 ft.	0328066666	HOSE CLEAR BRAID 3/4 "
8	1	0421051239	SEA STRAINER ASSY .75 BRONZE
9	4	05181432AA	HOSE CLAMP 1/2 SS "
10	14	05181434AA	HOSE CLAMP 3/4 SS "
11	5	061080028000	WASHER FLAT #10 SS
12	12	061100043000	WASHER FLAT OS 1/4SS "
13	5	061170628016	SC PHIL PAN A" 10 X 1 SS "
14	12	061172143016	SC HEX A" 1/4 X 1.0 SS "
15	1	0204741870	TEE 1/4 TUBE GJ X 1/4 TUBE GJ
16	1	01120125DG	ELB90 1/2 FPT X 1/2 FPT NY
17	1	01120137DG	ELB90 3/4 X 3/4 FPT NY
18	1	01122923DG	RB 1/2 MPT X 1/4 FPT NYLON



Exploded Parts View

B006080002 SEA STRAINER ASSY 3/4-B

ITEM NO.	QTY.	PART NO.	DESCRIPTION
1	1	B006080002	SEA STRAINER ASSY 3/4-B (INCLUDES P/N 2-7)
2	2	0101073783	ELB90 .75 MNPT X .75 BARB PVC
3	4	05181434AA	HOSE CLAMP 3/4" SS
4	1	0421051239	SEA STRAINER-3/4 BRONZE
5	1	0421051239-1	SIGHT GLASS
6	1	0421051239-7	BASKET MONEL
7	1	0421051239-2	O-RING, LID SEA STRAINER

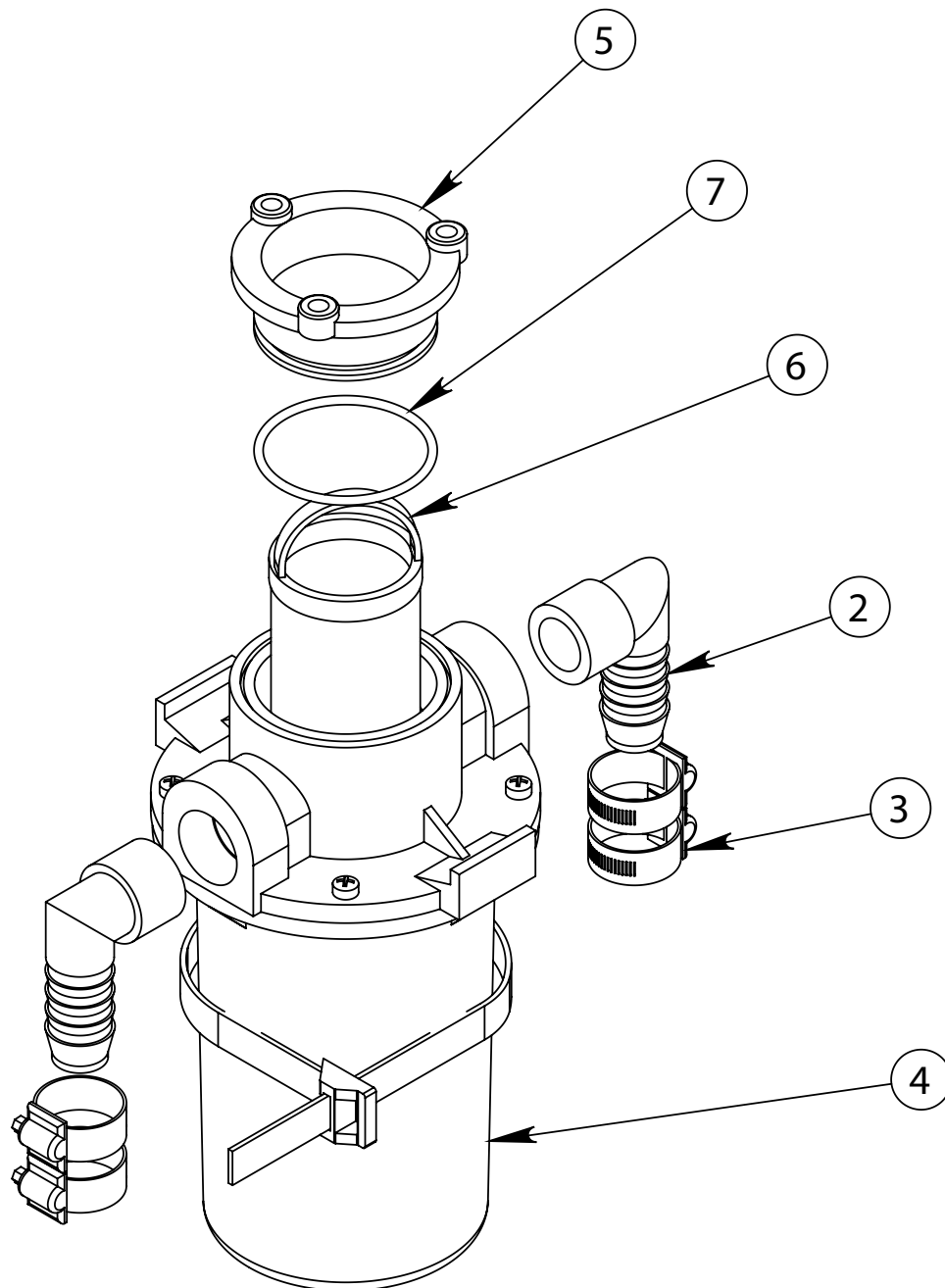

B008800001 PLANKTON FILTER ASSY-AW SINGLE

ITEM NO.	QTY.	PART NO.	DESCRIPTION
1	1	B008800001	PLANKTON FILTER ASSY-AW SINGLE (INCLUDES P/N 2-7)
2	4	05181434AA	HOSE CLAMP 3/4" SS
3	1	0805823578	ELEMENT PLANKTON
4	2	0101073783	ELB90 .75 MNPT X .75 BARB PVC
5	1	20200402102	SINGLE FILTER BRACKET
6	1	0713020473	FILTER HOUSING-LID .75 X 10 ASM
7	1	2614010473	O-RING 237 BLUE HOUSING

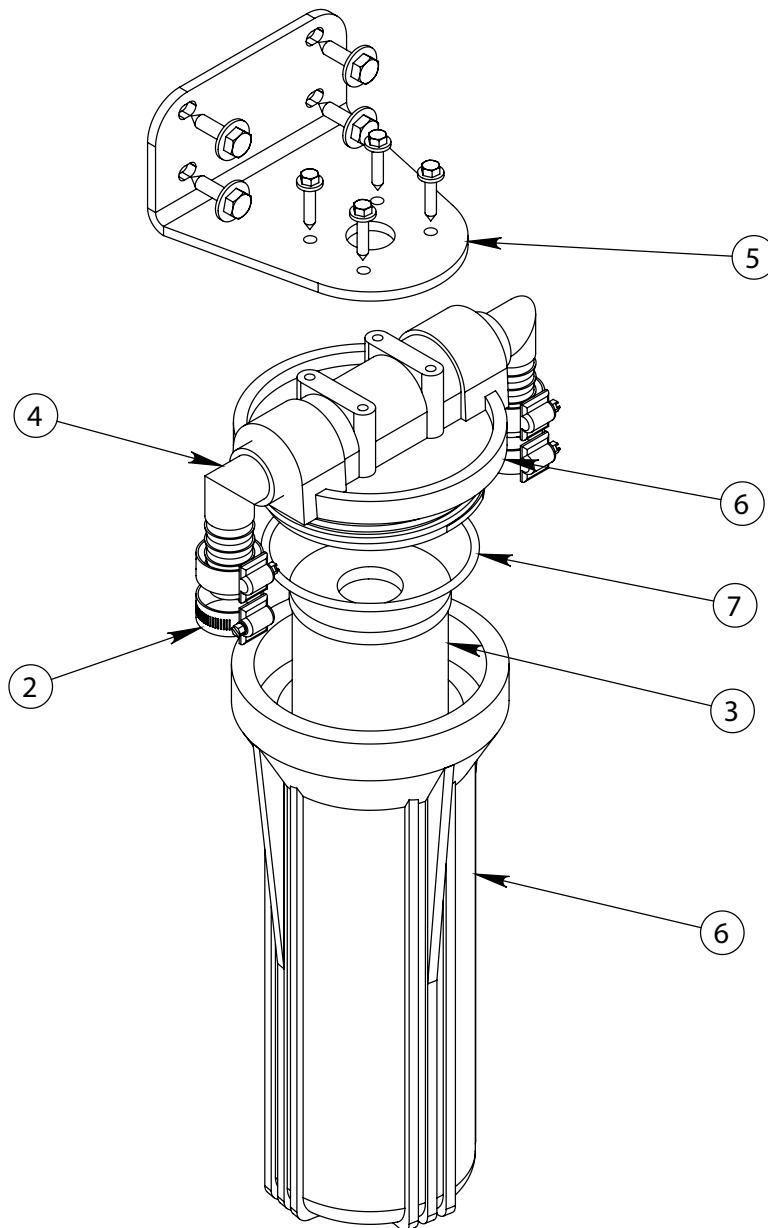

Exploded Parts View

B008800002 PLANKTON FILTER ASSY-AW DOUBLE

ITEM NO.	QTY.	PART NO.	DESCRIPTION
1	2	0713020473	FILTER HOUSING/LID 3/4 X 10
2	4	01013737CL	NIPPLE 3/4 NPT X CLOSE PVC "S
3	2	0101423783	TEE 3/4 FT X 3/4 FT X 3/4 FT P
4	3	0101653783	ADAP 3/4 MPT X 3/4 BARB PVC
5	2	0101013783	ELB90 3/4 FPT X 3/4 FPT PVC
6	3	0101073783	ELB90 3/4 MPT X 3/4 BARB PVC
7	2	0328066666	HOSE CLEAR BRAID 3/4"
8	12	05181434AA	HOSE CLAMP 3/4" SS
9	2	0805823578	ELEMENT PLANKTON
10	2	20200402102	SINGLE FILTER BRACKET
11	8	061172143016	SC HEX "A" 1/4 X 1 SS
12	8	061100043000	WASHER FLAT OS 1/4"SS
13	8	061170628016	SC PHIL PAN "A" 10 X 1 SS
14	8	065080028000	WASHER FLAT #10 NYLON

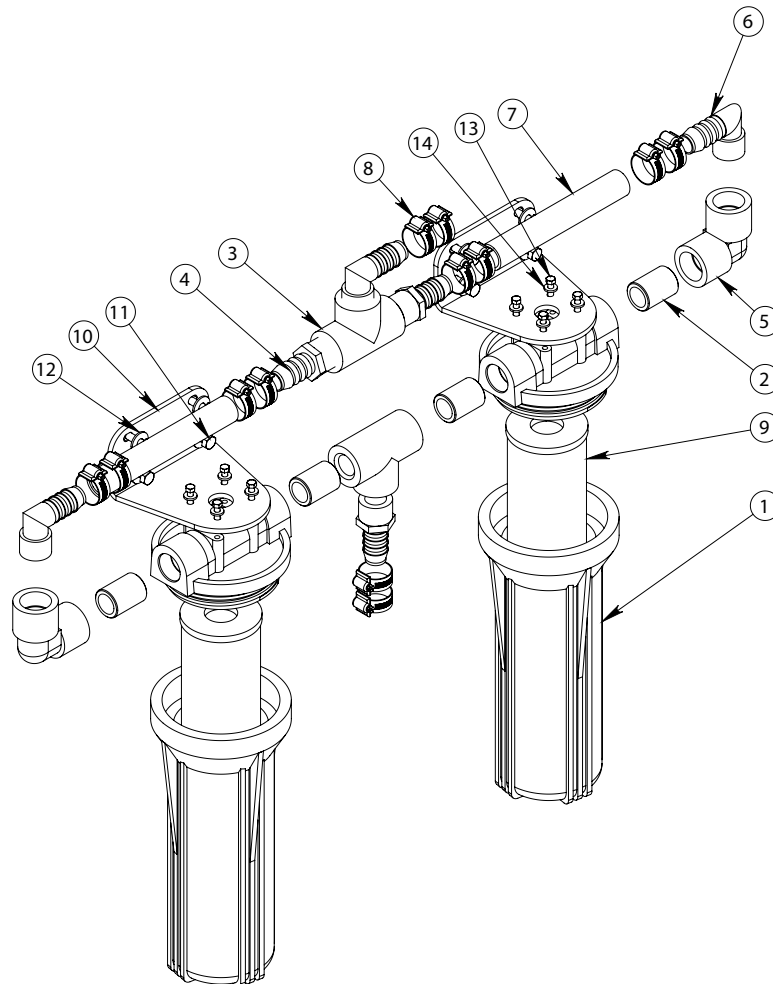

B016080026 BOSTR PMP ASY 110-230-50-60-1P

BILL OF MATERIAL (B.O.M.)			
ITEM NO.	FILE/DWG. NAME	DESCRIPTION	QTY.
1	1221515772-1	BOOSTER PUMP VOLUTE N200	1
2	1221515772-2	MOTOR MOUNTING BRACKET	1
3	1221515772-3	SEAL BOOSTER PUMP HEAD	1
4	29121181PP	IMPELLER	1
5	1519081110	MOTOR .50 HP 110-230-50-60-1PH	1
6	1920023632	STRAIN RELIEF 90 CG90-6250	1
7	01120737DG	ELB90 0.75 MPT x BARB NYLON	1
8	0112653700	ADAP 0.75 MPT x BARB NYLON	1
9	061010057000	NUT,HEX,3/8-16,SS	7
10	061080056000	WASHER,FLAT,3/8",SS	4
11	061100043000	WASHER FLAT OS .25 SS	4
12	061142157024	SCREW,HEX HEAD,3/8-16x1-1/2",SS	4
13	061172143016	SCREX,HEX A,.25x1.00,SS	4
14	063200066000	NUT LOCK .50 STEEL	1
15	1221515772-4	SCREW HEX .312-16 x 1.5LG	7
16	1221515772-5	WASHER FLAT .312	7
17	26141260PP	GASKET BOOSTER PUMP N200	1

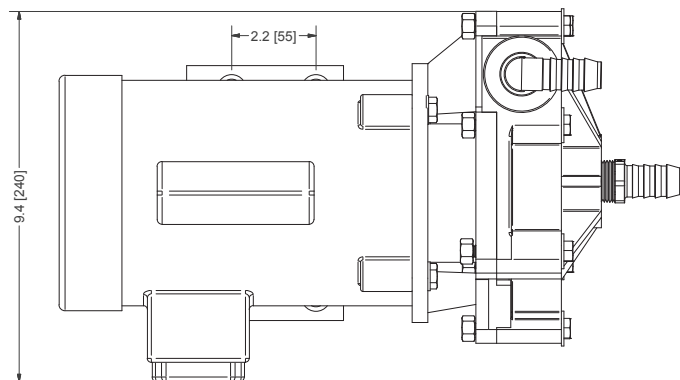
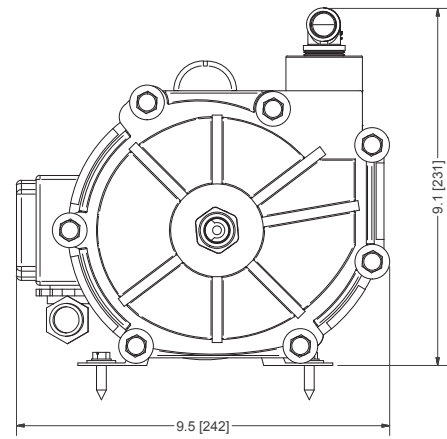
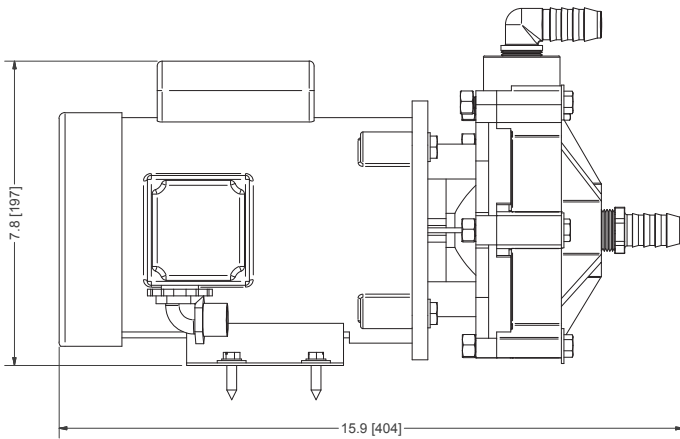

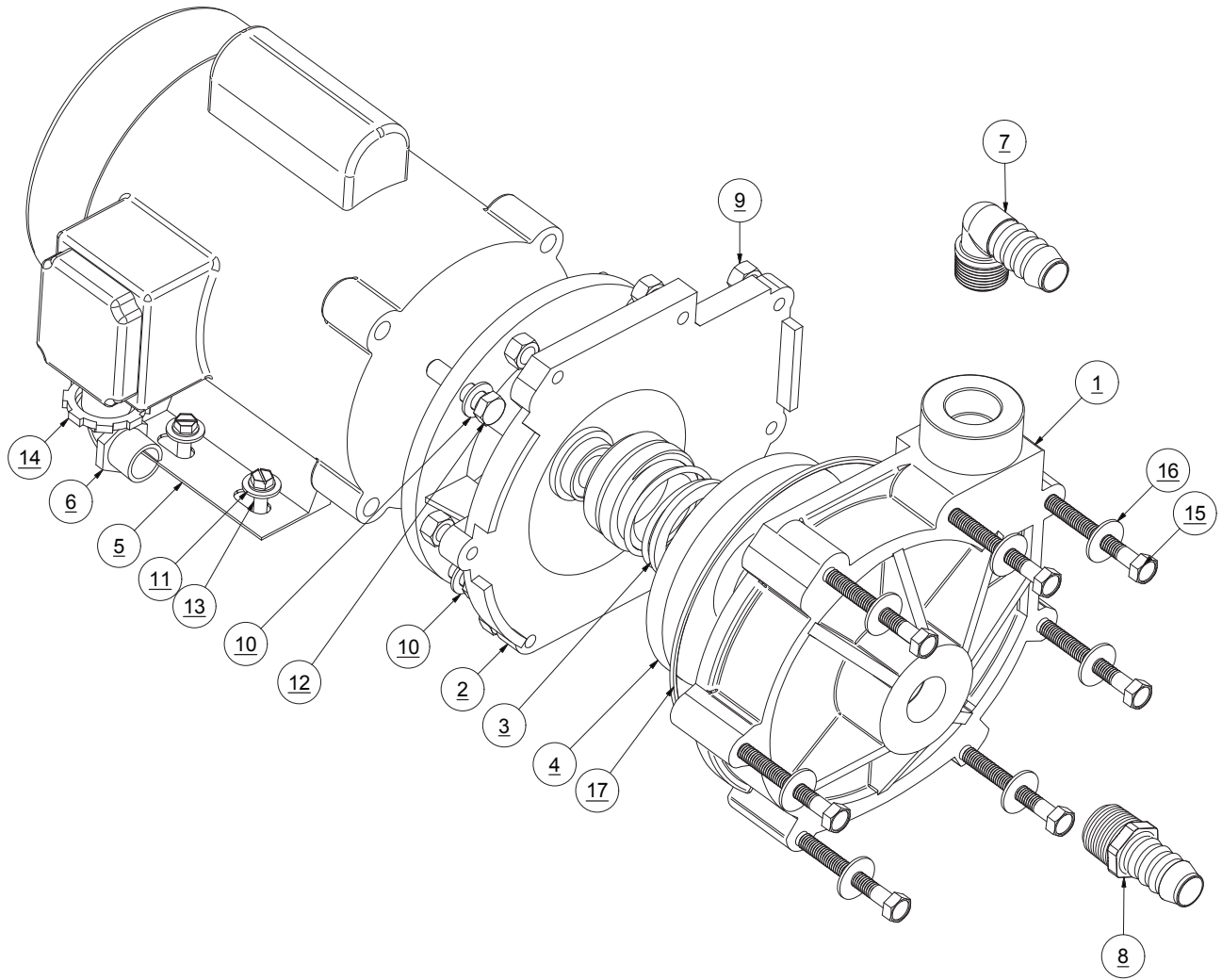

RECOMMENDED SPARES:

QTY.	PART NUMBER	DESCRIPTION
1	B655800009	SEAL KIT BOOSTER PMP N200
1	B655800012	SEAL KIT BOOSTER PMP N200/HP75
1	291211181PP	IMPELLER 4.8 N200

B016080027 BOSTR PMP ASY 208-460-50-60-3P

BILL OF MATERIAL (B.O.M.)			
ITEM NO.	FILE/DWG. NAME	DESCRIPTION	QTY.
1	1221514722-3	BRACKET,MTG,PUMP,BOOSTER	1
2	1221515772-1	BOOSTER PUMP VOLUTE N200	1
3	1221515772-2	MOTOR MOUNTING BRACKET	1
4	1221515772-3	SEAL BOOSTER PUMP HEAD	1
5	29121181PP	IMPELLER	1
6	1520181110	MOTOR .50 HP 208-230-460-50-60	1
7	1920023632	STRAIN RELIEF 90 CG90-6250	1
8	01120737DG	ELB90 0.75 MPT x BARB NYLON	1
9	0112653700	ADAP 0.75 MPT x BARB NYLON	1
10	061010057000	NUT,HEX,3/8-16,SS	7
11	061080056000	WASHER,FLAT,3/8",SS	4
12	061100043000	WASHER FLAT OS .25 SS	4
13	061142157024	SCREW,HEX HEAD,3/8-16x1-1/2",SS	4
14	061172143016	SCREX,HEX A,.25x1.00,SS	4
15	063200066000	NUT LOCK .50 STEEL	1
16	1221515772-4	SCREW HEX .312-16 x 1.5LG	7
17	1221515772-5	WASHER FLAT .312	7
18	26141260PP	GASKET BOOSTER PUMP N200	1

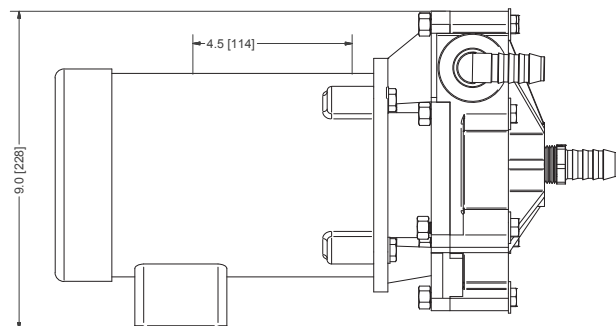
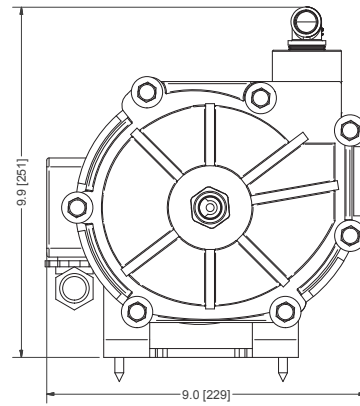
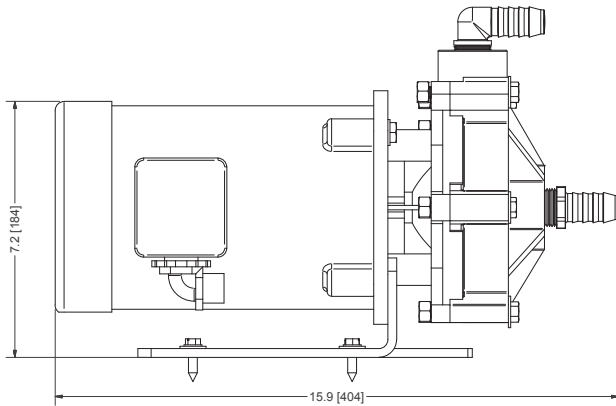

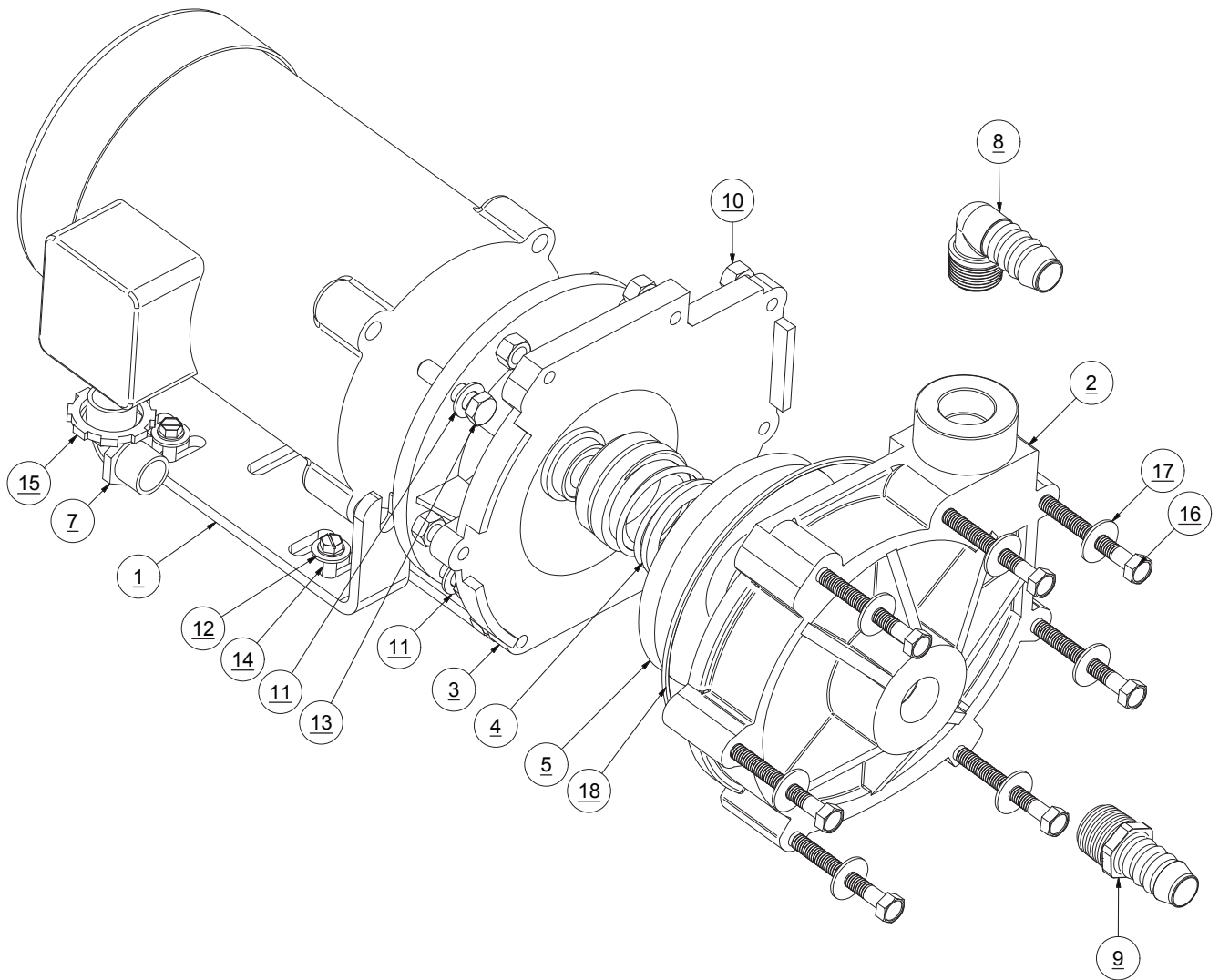

RECOMMENDED SPARES:

QTY.	PART NUMBER	DESCRIPTION
1	B655800009	SEAL KIT BOOSTER PMP N200
1	B655800012	SEAL KIT BOOSTER PMP N200/HP75
1	291211181PP	IMPELLER 4.8 N200

B075000001 MULTI MEDIA FILTER PLUMBING ASSY

ITEM NO.	QTY	PART NO.	DESCRIPTION
1	2	05180851CC	GAUGE BRACKET CBM SS
2	1	0101693783	UNION .75 SL x .75 SL PVC
3	1	0101673783	UNION .75 FNPT x .75 FNPT PVC
4	3	14011317AR	VALVE 3-WAY BALL .75 SL
5	3	0101652683	ADAP 1/2 MPT X 3/4 BARB PVC
6	2	0204020869	ELB90 1/4 TUBE X 1/4 MPT PLAST
7	6	05181434AA	HOSE CLAMP 3/4" SS
8	3	1453131700-02	VALVE BRACKET 3/4" SL, SET
9	6	061161130028	SC PHIL OVAL 10-24 X 1 1/4 SS
10	3	0101313683	RB .75 SL x .50 FNPT PVC
11	2	0101323483	RB .75 SL x .25 FNPT PVC
12	12	0101053783	ELB90 .75 SL X .75 SL PVC
13	11	0301096600	PIPE PVC SCH 80 .75 DIA x 1.75LG
14	2	0312121969	TUBE .25 BLK SEMI-RIGID NYLON
15	2	0301096600	PIPE PVC SCH 80 3/4" PER FOOT
16	4	0101463783	TEE .75 SL x .75 SL x .75 SL PVC
17	8	0301096600	PIPE PVC SCH 80 .75 DIA x 3.625LG
18	1	0328066666	HOSE CLEAR BRAID 3/4"
19	2	01013737CL	NIPPLE .75 NPT X CLOSE PVC

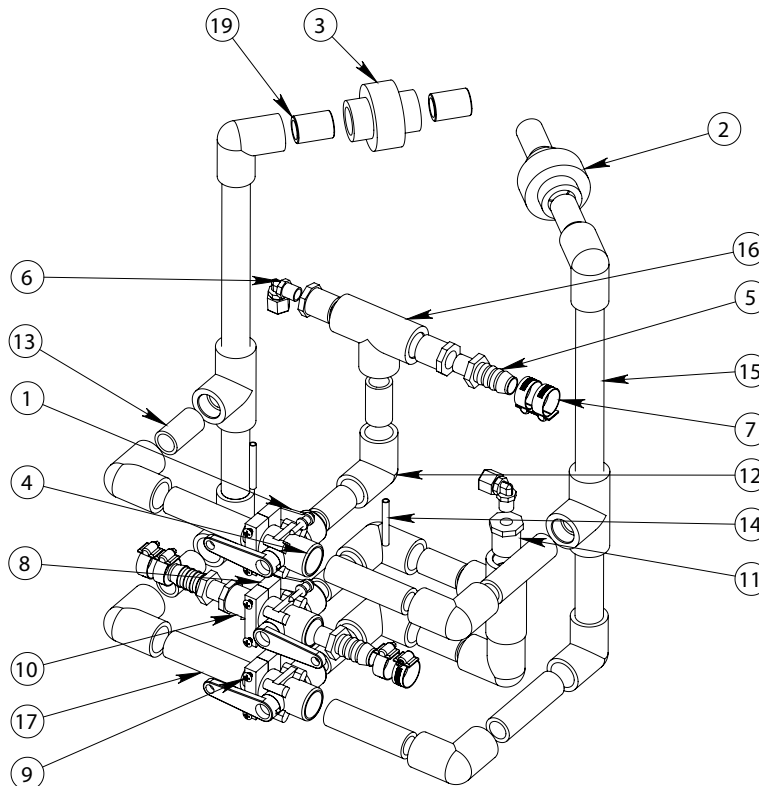

Exploded Parts View

B071080002 MEDIA FILTER ASSY -4 HS/AW/UW

ITEM NO.	QTY	PART NO.	DESCRIPTION
1	1	0708040468-1	MEDIA FILTER HOUSING 818 ALMOND
2	4	20200404010	BRACKET L" MOUNTING FEET
3	1	20200325000	SKID MEDIA FILTER AS>7/97
4	16	061100043000	WASHER FLAT OS 1/4"SS
5	8	061060045000	NUT HEX 1/4-20 W/INSERT SS
6	2	05180851CC	GAUGE BRACKET CBM SS
7	2	0204010869	ELB90 1/4 TUBE X 1/4 FPT PLAST
8	4	061142145012	BOLT HEX 1/4-20 X 3/4 SS
9	4	061161845012	SC ALLEN FLAT 1/4-20 X 3/4 SS
10	1	0708040400-1	MEDIA FILTER TOP
11	1	0708040400-2	MEDIA FILTER RISER
12	25 LB.	4643020255	MEDIA SAND A1000 (100LB BAG)
13	17 LB.	4643070155	MEDIA GARNET 8-12 50# BAG
14	1	2614017300	O-RING 334 MEDIA LID 97
15	1	2614013001	O-RING 209
16	1	2614017400	O-RING 117 MEDIA TOP INLET
17	1	0708040400-3	PLUG MEDIA FILTER TOP
18	1	B075000001	MULTI MEDIA FILTER PLUMBING
19	2	10181522CC	GAUGE -30/0/70 CBM.NPT

Refer to drawing on next page.

MEDIA SAND
#A1000
25 POUNDS

MEDIA GARNET
8-12
17 POUNDS

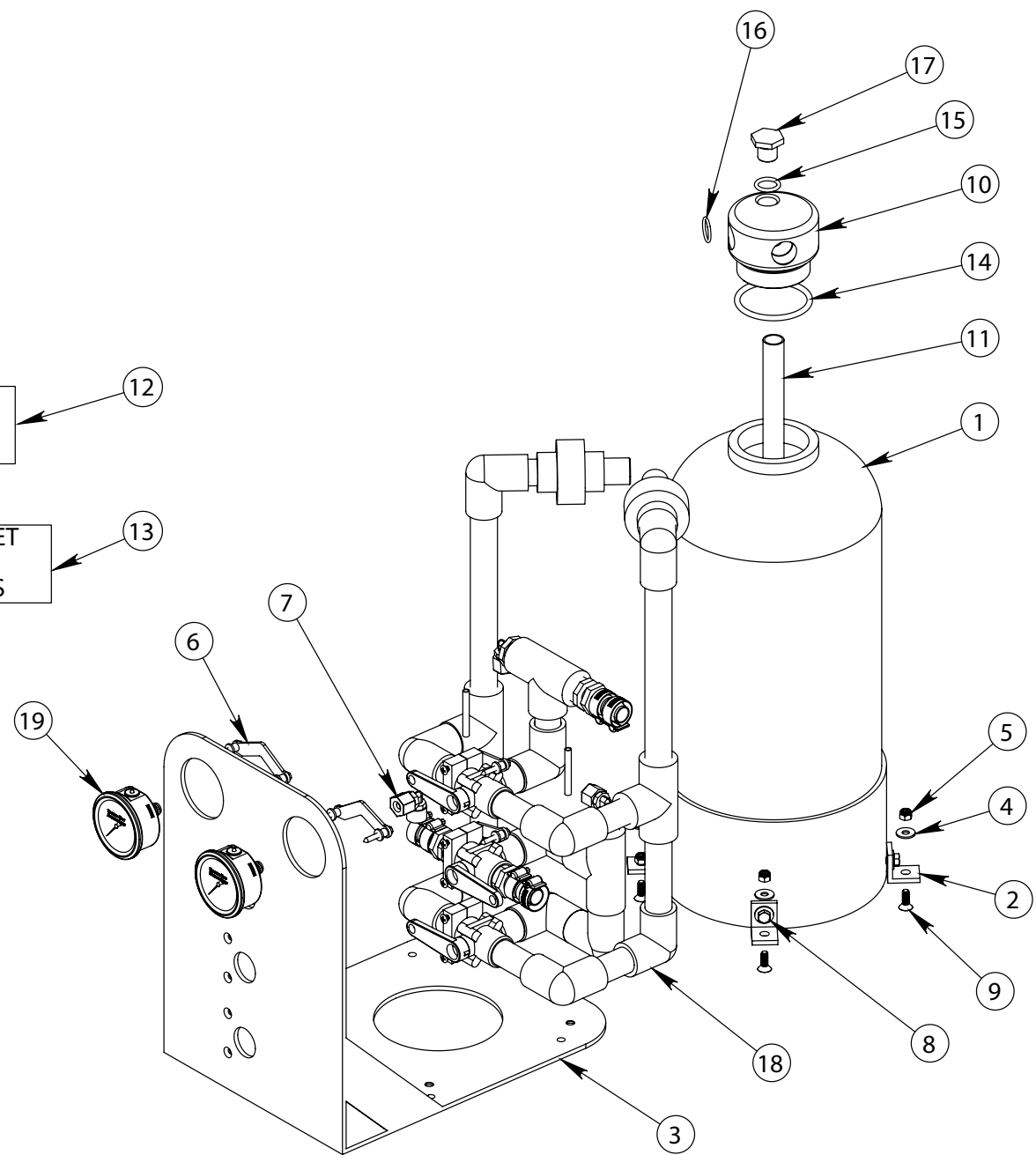

PREFILTRATION CARTRIDGE FILTER ELEMENT WARNING:

Do not use third party Prefiltration Elements (Plankton Filter Elements, Prefilter Elements, Commercial Prefilter Elements, or Oil/Water Separator Elements). Use only Sea Recovery supplied Prefiltration Elements. Third party prefiltration elements on the market do not properly fit into the Sea Recovery Filter Housings, the seams fall apart, and they will allow by-pass resulting in EXTENSIVE AND EXPENSIVE DAMAGE TO THE HIGH PRESSURE PUMP AS WELL AS PREMATURE FOULING OF THE R.O. MEMBRANE ELEMENT.

Damage caused to the Sea Recovery High Pressure Pump, R.O. Membrane Element, or any other component from the use of third party, non Sea Recovery supplied, filter elements is the responsibility and liability of the operator and is not covered by the Sea Recovery Warranty.

FILTER ELEMENT CAUTION:

Do not use "string wound" or "fiber" type prefilter elements. These type of elements are designed for the Photographic Film Developing industry. When used in sea water they will plug up rapidly in 1/10th or less the time causing frequent shut down of the system and very frequent changing resulting in very high cost of maintenance.

B108140001 PREFILTER DUAL AQM II

⊘ Caution: Do not use third-party pre-filtration components! Use only Sea Recovery Corporation pre-filtration components. Third-party pre-filtration components do not fit properly, thus causing the seams to fall apart. They also allow bypass, which results in extensive damage to the High Pressure Pump, as well as to premature fouling of the RO Membrane Element.

ITEM NO.	QTY	PART NO.	DESCRIPTION
1	1	B108140001	PREFILTER DUAL AQM II (INCLUDES P/N 2-8)
2	1	0801130257	ELEMENT PREFILTER 10-25
3	1	0801060157	ELEMENT PREFILTER 10-05
4	1	20200402101	DUAL BRACKET PREFILTER, CHRCL, PLNKTN
5	2	0112072600	ELB90 1/2 MPT X 3/4 BARB NYLON
6	4	05181434AA	HOSE CLAMP 3/4" SS
7	2	2614010473	O-RING 237 BLUE HOUSING
8	2	0713020873	FILTER HOUSING 1/2" X 10

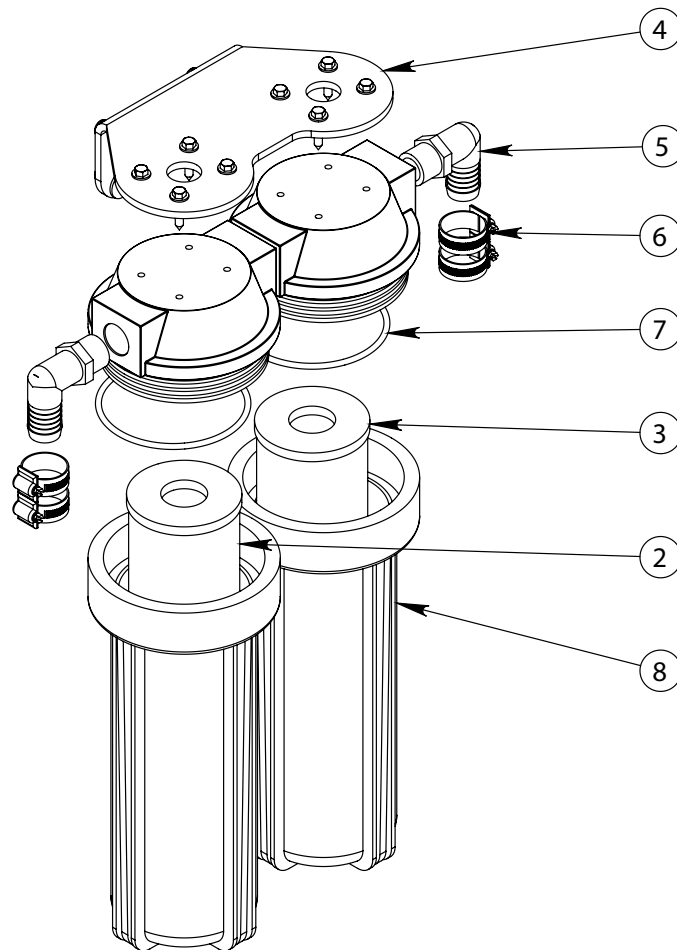

Exploded Parts View

COMMERCIAL PREFILTER CONNECTION AND WATER FLOW

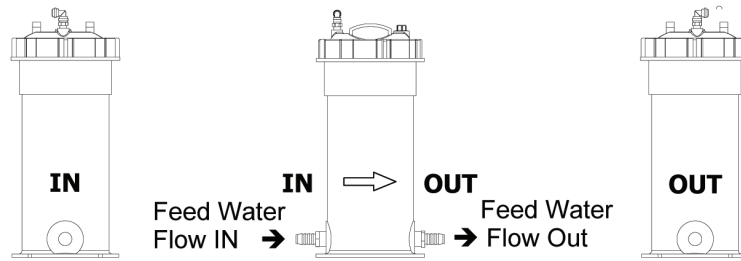

Commercial Prefilter is plumbed as per the raised arrows and markings IN and OUT

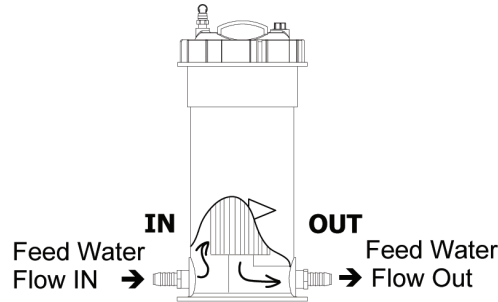

Feed Water Flow through the Commercial Prefilter Element is from the OUTSIDE of the Element to the INSIDE CENTER of the Element

OIL/WATER SEPARATOR CONNECTION AND WATER FLOW

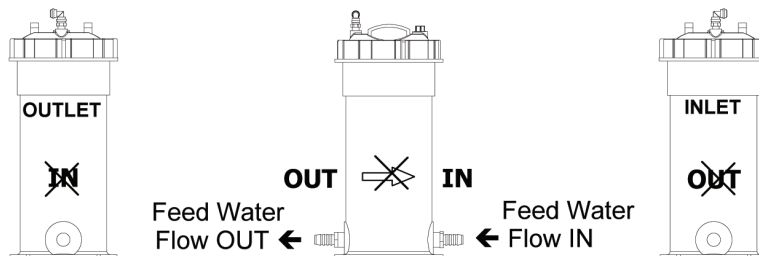

Oil/Water Separator utilizes the same housing as the Commercial Prefilter, however it is plumbed OPPOSITE of the Commercial Prefilter and OPPOSITE of the raised arrows and markings IN and OUT Separate Labels are placed on the Oil/Water Separator indicating correct INLET and OUTLET

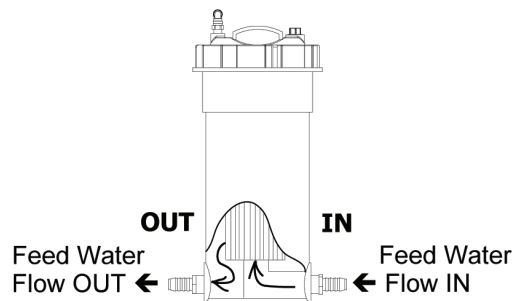

Feed Water Flow through the Oil/Water Separator Element is from the INSIDE CENTER of the Element to the OUTSIDE of the element

B109120001 COMMERCIAL PREFILTER ASSY 32.5 SQ FT SRC AQM

ITEM NO.	QTY	PART NO.	DESCRIPTION
1	1	B109120001	COMMERCIAL PREFILTER ASSY 32.5 SQ FT (INCLUDES P/N 2-11)
2	2	2614018969	O-RING 034 FOR COMMERCIAL FILTER
3	2	3901040100	ADAPTER SPACER RING
4	1	0204020100	ELB90 .25 TUBE JQ x .25MNPT
5	1	0204990300	PLUG 1/4 JQ
6	4	05181434AA	HOSE CLAMP 3/4" SS
7	1	0801063357	ELEMENT CPFE 5 MIC 32.5 SQFT
8	2	0101653783	ADAP 3/4 MPT X 3/4 BARB PVC
9	15 FT.	0312121969	TUBE .25 BLK SEMI-RIGID NYLON
10	1	07620310WA	FILTER HOUSING 32.5SQFT >10/01
11	1	07620310WA-06	O-RING LID CPF/OWS 32.5SQFT

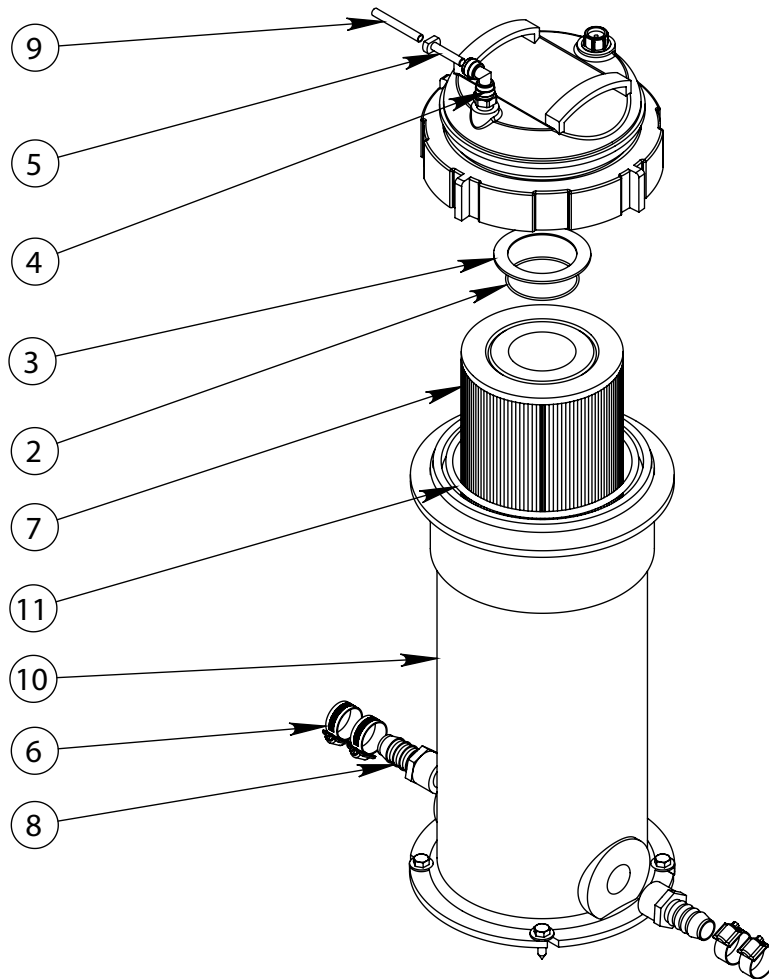

B111120001 OIL/WATER SEPARATOR ASSY SRC 32.5 SQ FT

ITEM NO.	QTY	PART NO.	DESCRIPTION
1	1	B111120001	OIL / WATER SEPARATOR ASSY SRC 32.5 SQ FT (INCLUDES P/N 2-9)
2	1	08020723KD	ELEMENT OWSE 32.5 SQFT
3	2	0101653783	ADAP 3/4 MPT X 3/4 BARB PVC
4	3	05181434AA	HOSE CLAMP 3/4" SS
5	1	0204020100	ELB90 .25 TUBE JQ x .25MNPT
6	1	0204990300	PLUG 1/4 JQ
7	1	0312121969	TUBE .25 BLK SEMI-RIGID NYLON
8	1	07620310WA	FILTER HOUSING 32.5SQFT >10/01
9	1	07620310WA-06	O-RING LID CPF/OWS 32.5SQFT

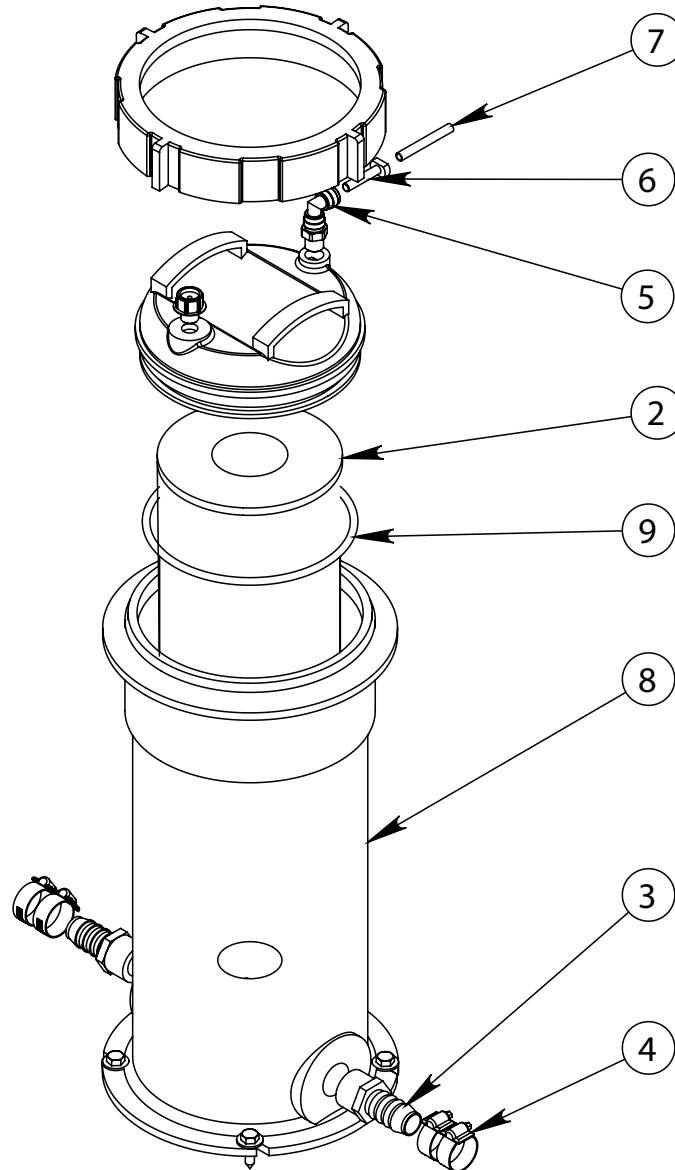

B114140001 PH NEUTRALIZER / CHARCOAL DUAL AQMC II / MOD

ITEM NO.	QTY.	PART NO.	DESCRIPTION
1	1	B114140001	PH NEUTRALIZER / CHARCOAL DUAL AQMC II / MOD (INCLUDES P/N 2-9)
2	2	0713020573	FILTER HOUSING/LID 3/8 X 10
3	1	20200402101	DUAL BRACKET, PRE-FILTER, CHRCL/PLNKTN
4	1	08251950AS	ELEMENT PH 9 3/4"
5	1	0803004773	CHARCOAL FILTER 10 IN
6	1	0204021869	ELB90 3/8 TUBE X 3/8 MPT PLASTIC
7	1	0112071900	ELB90 3/8 X 1/2 BARB NYLON
8	1	01013718CL	NIPPLE 3/8 NPT X CLOSE PVC
9	2	2614010473	O-RING 237 BLUE HOUSING

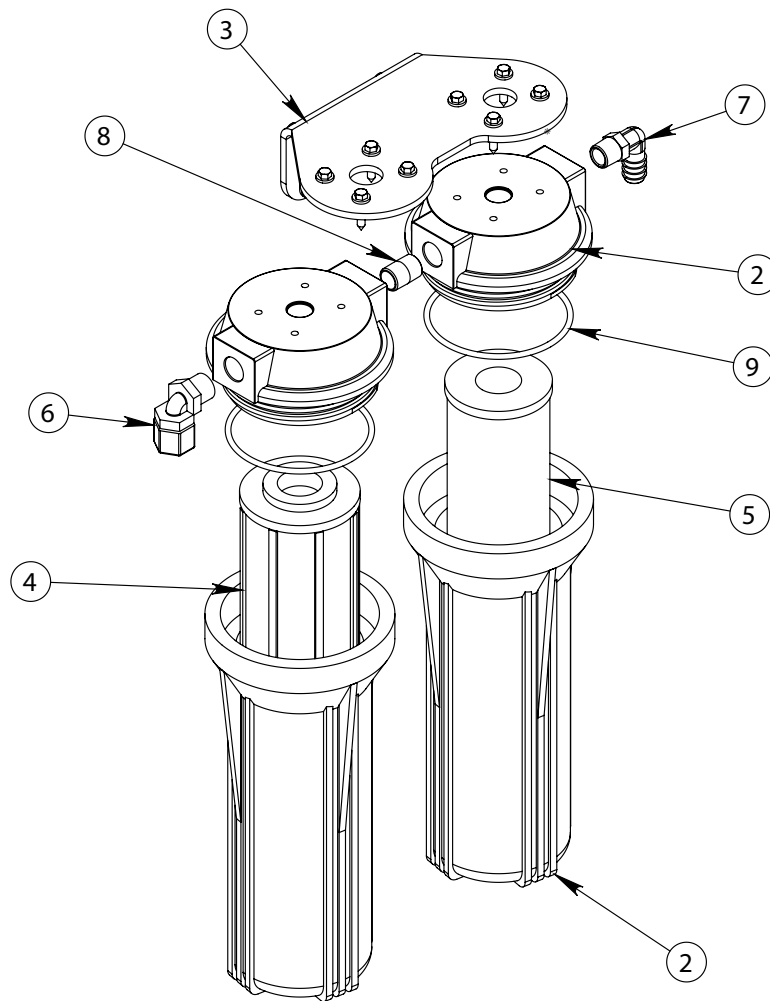

B156140001 HP PUMP / MOTOR ASSY AQMCII APP

ITEM NO.	QTY.	PART NO.	DESCRIPTION
1	1	B156140001	HP PUMP MOTOR ASSY 1 PHASE (INCLUDES P/N 2-24)
2	1	15AE261912	MOTOR 3/2.5 HP 115/230 1PH
3	1	12572405DS	HPRA PUMP 4.37 GPM (CP)
4	1	1317021869	ELB90 -6 FLARE X 3/4 UNF SS
5	1	12207602RW	COUPLER TX1 AQM2
6	2	061120091000	WASHER SPLIT LOCK M6 SS
7	2	061142191174	HEX BOLT M6 X 20MM SS
8	1	1220770101	BELL HOUSING AQ/AW 1PH
9	1	01126526DG	ADAP 1/2 MPT X 3/4 BARB NYLON
10	1	2317100300	TRANSDUCER 0-2000 PSI 7/16" SAE
11	1	2317100200	TRANSDUCER 0-200 PSI 7/16" SAE
12	1	20200239000	PLATE MOTOR MOUNT AQMCII
13	4	2020043902	SPACER MOTOR MOUNT AQMCII
14	4	2115031700	RUBBER MOUNT 90 LB AQM
15	1	1904040600	STRAIN RELIEF 1/2" BLK LT50P
16	4	061080056000	WASHER FLAT 3/8" SS
17	4	061142157016	BOLT HEX 3/8-16 X 1 SS
18	4	061142150016	BOLT HEX 5/16-18 X 1.0LG SS
19	12	061100049000	WASHER FLAT OS 5/16" SS
20	8	061060050000	HEX NUT 5/16-18 W/INSERT SS
21	4	061142150032	BOLT HEX 5/16-18 X 2" SS
22	4	061110049000	WASHER FENDER .312 SS
23	1	4928402800	CONDUIT .50 FLEX BLK
24	1	1920016590	STRAIN RELIEF 90, .50 BLK W-NUT

Refer to drawing on next page.

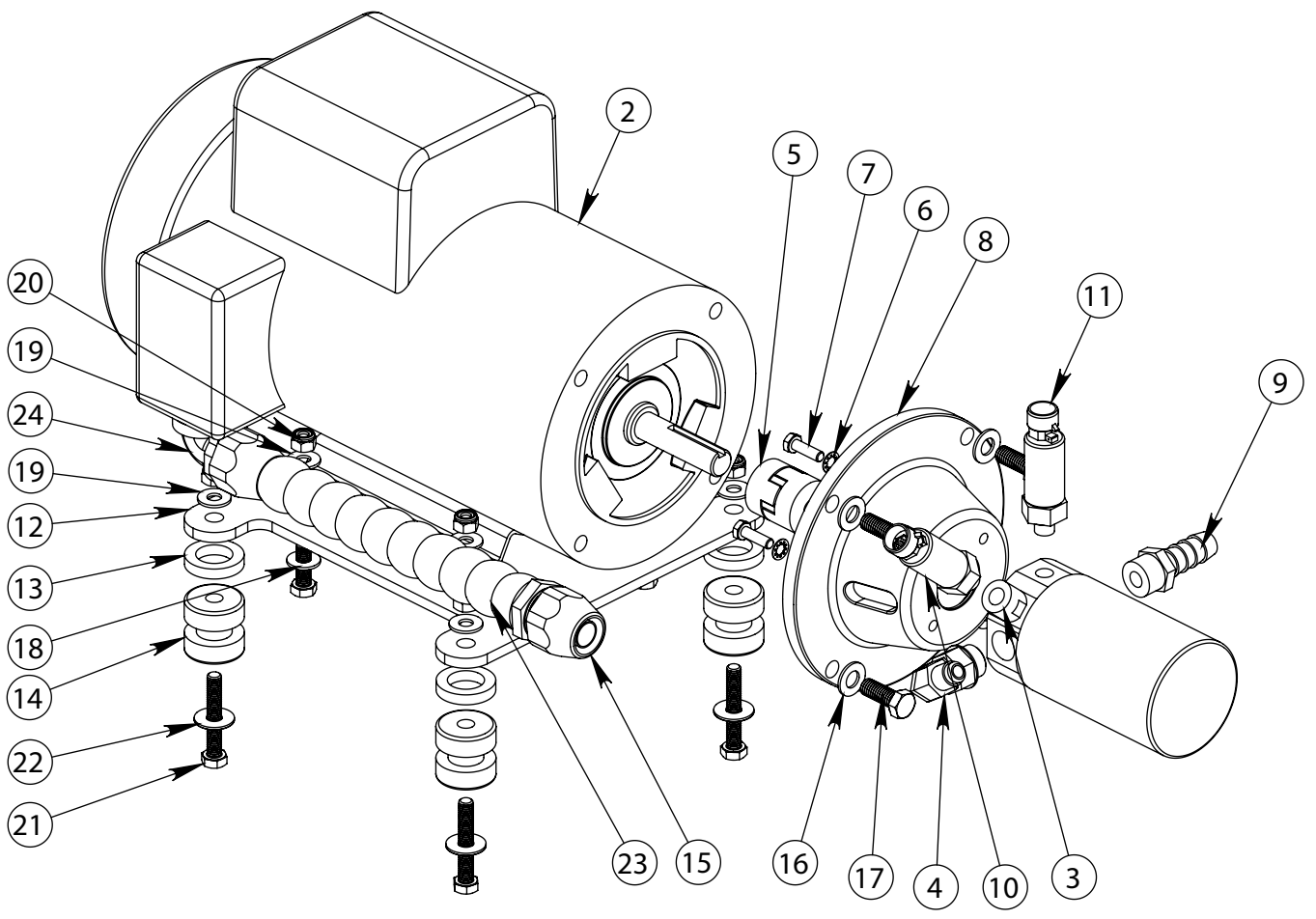

B156140002 HP PUMP / MOTOR ASSY AQMCII APP 3PH

ITEM NO.	QTY.	PART NO.	DESCRIPTION
1	1	B156140002	HP PUMP / MOTOR ASSY AQMC II 3PH (INCLUDES P/N 2-24)
2	1	15AF271910	MOTOR 3/2.5 HP 3 PH AQM 50/6
3	1	12572405DS	HPRA PUMP 4.37 GPM (CP)
4	1	1317021869	ELB90 -6 FLARE X 3/4 UNF SS
5	1	12207602RW	COUPLER TX1 AQM2
6	2	061120091000	WASHER SPLIT LOCK M6 SS
7	2	061142191174	HEX BOLT M6 X 20MM SS
8	1	1220770103	BELL HOUSING AQ/AW 3PH
9	1	01126526DG	ADAP 1/2 MPT X 3/4 BARB NYLON
10	1	2317100300	TRANSDUCER 0-2000 PSI 7/16" SAE
11	1	2317100200	TRANSDUCER 0-200 PSI 7/16" SAE
12	1	20200239000	PLATE MOTOR MOUNT AQMCII
13	4	2020043902	SPACER MOTOR MOUNT AQMCII
14	4	2115031700	RUBBER MOUNT 90 LB AQM
15	1	1904040600	STRAIN RELIEF 1/2" BLK LT50P
16	4	061080056000	WASHER FLAT 3/8" SS
17	4	061142157016	BOLT HEX 3/8-16 X 1 SS
18	12	061100049000	WASHER FLAT OS 5/16" SS
19	8	061060050000	HEX NUT 5/16-18 W/INSERT SS
20	1	1920016590	STRAIN RELIEF 90, .50 BLK W-NUT
21	1	4928402800	CONDUIT .50 FLEX BLK
22	4	061142150016	BOLT HEX 5/16-18 X 1.0LG SS
23	4	061142150032	BOLT HEX 5/16-18 X 2" SS
24	4	061110049000	WASHER FENDER .312 SS

Refer to drawing on next page.

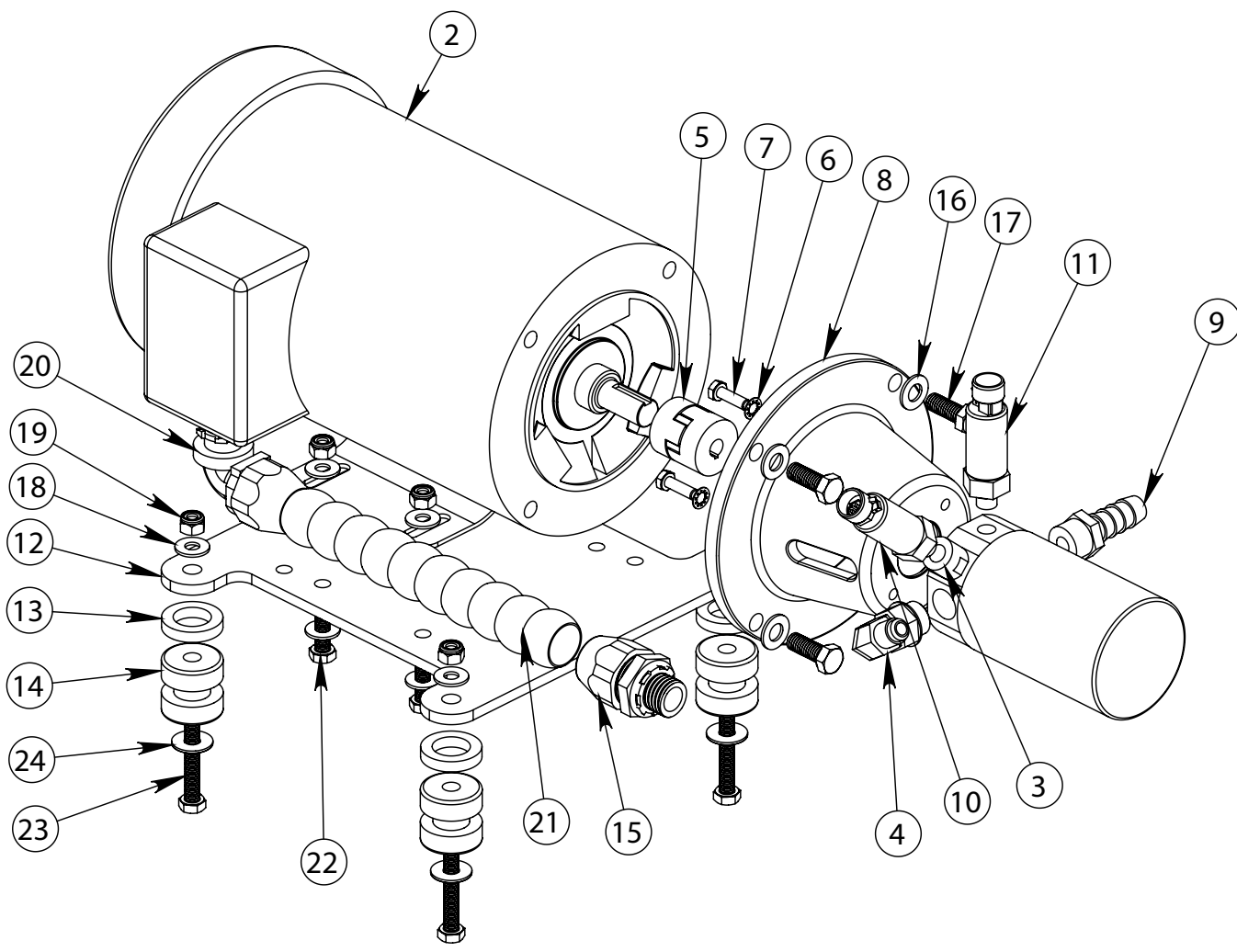

B156140003 HP PUMP/MOTOR ASSY AQMCII PLGR 110/220/5/6/1PH (Standard)

ITEM NO.	QTY	PART NO.	DESCRIPTION
1	1	B156140003	HP PUMP MOTOR ASSY AQMC II PLGR 110/220/5/6/1PH (INCLUDES P/N 2-21)
2	1	15AC062412	MOTOR 2.5 HP 50/60 110/220
3	4	061142157016	BOLT HEX 3/8-16 X 1 SS
4	4	061080056000	WASHER FLAT 3/8" SS
5	4	061142150016	BOLT HEX 5/16-18 X 1.0LG SS
6	8	061060050000	HEX NUT 5/16-18 W/INSERT SS
7	12	061100049000	WASHER FLAT OS 5/16" SS
8	4	061142150032	BOLT HEX 5/16-18 X 2" SS
9	4	2020043902	SPACER MOTOR MOUNT AQMCII
10	4	2115031700	RUBBER MOUNT 90LB AQM
11	1	12180512CO	HP PUMP-GP 4.2 GPM SS LEFTHAND
12	1	20200239002	PLATE, GP MOTOR MOUNT PLATE AQWC II
13	1	1920016590	STRAIN RELIEF 90, .50 BLK W-NUT
14	1	4928402800	CONDUIT .50 FLEX BLK
15	1	1317021969	ELB90 -6 FLARE X 3/8 MPT SS
16	1	5353140903	MANIFOLD HP TRANSDUCER AQMW
17	1	01173818CL	NIPPLE HEX .375 NPT X CLOSE SS
18	1	2317100300	TRANSDUCER 0-2000 PSI 7/16" SAE
19	1	0112072600	ELB90 1/2 MPT X 3/4 BARB NYLON
20	1	1904040600	STRAIN RELIEF 1/2" BLK LT50P
21	4	061110049000	WASHER FENDER .312 SS

Refer to drawing on next page.

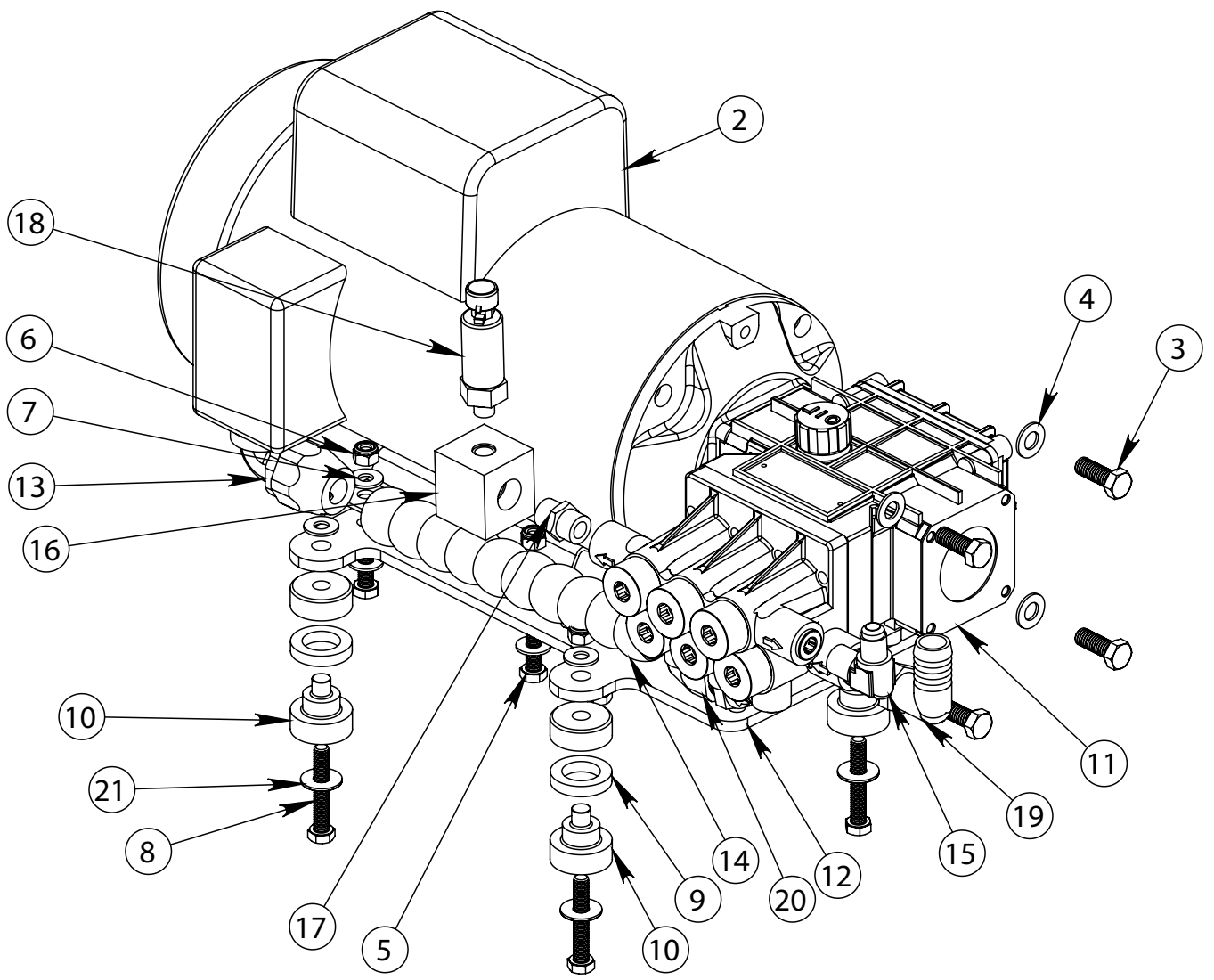

B156140004 HP PUMP/MOTOR ASSY AQMCII PLGR 220/440/60/3PH

ITEM NO.	QTY	PART NO.	DESCRIPTION
1	1	B156140004	HP PUMP MOTOR ASSY AQMC II PLGR 220/440/60/3PH (INCLUDES P/N 2-21)
2	4	061142157016	BOLT HEX 3/8-16 X 1 SS
3	4	061080056000	WASHER FLAT 3/8" SS
4	4	061142150016	BOLT HEX 5/16-18 X 1.0LG SS
5	8	061060050000	HEX NUT 5/16-18 W/INSERT SS
6	12	061100049000	WASHER FLAT OS 5/16" SS
7	4	061142150032	BOLT HEX 5/16-18 X 2" SS
8	4	2020043902	SPACER MOTOR MOUNT AQMCII
9	4	2115031700	RUBBER MOUNT 90LB AQM
10	1	12180512CO	HP PUMP-GP 4.2 GPM SS LEFTHAND
11	1	20200239002	PLATE, GP MOTOR MOUNT PLATE AQWC II
12	1	1920016590	STRAIN RELIEF 90, .50 BLK W-NUT
13	1	4928402800	CONDUIT .50 FLEX BLK
14	1	1317021969	ELB90 -6 FLARE X 3/8 MPT SS
15	1	5353140903	MANIFOLD HP TRANSDUCER AQMW
16	1	01173818CL	NIPPLE HEX .375 NPT X CLOSE SS
17	1	2317100300	TRANSDUCER 0-2000 PSI 7/16" SAE
18	1	0112072600	ELB90 1/2 MPT X 3/4 BARB NYLON
19	1	1904040600	STRAIN RELIEF 1/2" BLK LT50P
20	4	061110049000	WASHER FENDER .312 SS
21	1	82012005	MTR 2.4HP 220-440/50-60 3PH

Refer to drawing on next page.

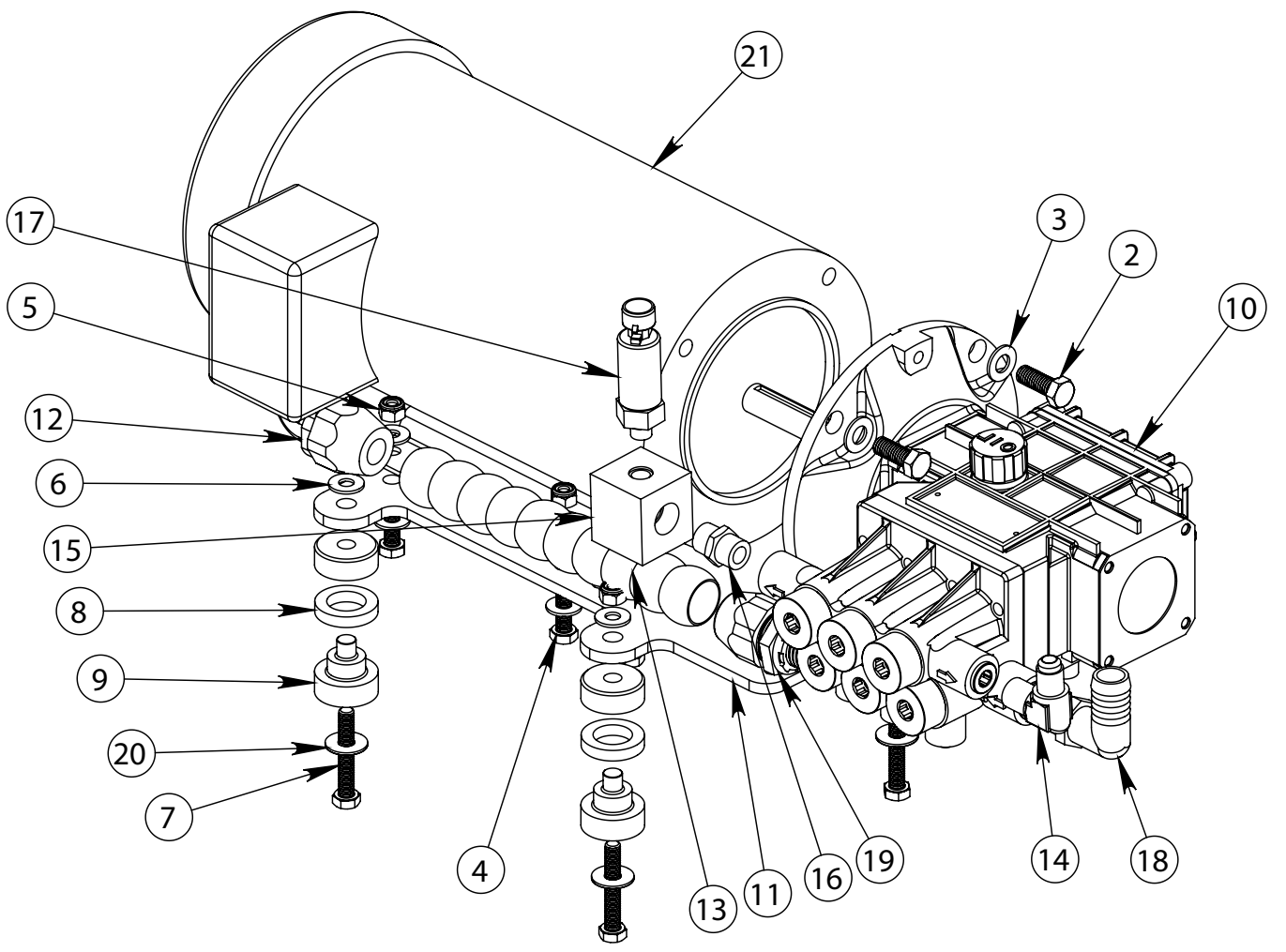

B156140006 HP PUMP/MOTOR PLGR AQMCII 110/220/6/1 SMALL 60 HZ

ITEM NO.	QTY	PART NO.	DESCRIPTION
1	1	B156140003	HP PUMP MOTOR PLGR AQMC II 110/220/6/1SMALL 60 HZ (INCLUDES P/N 2-21)
2	1	15AD062412	MOTOR 2.1 HP 50/60 110/220
3	4	061142157016	BOLT HEX 3/8-16 X 1 SS
4	4	061080056000	WASHER FLAT 3/8" SS
5	4	061080056000	BOLT HEX 5/16-18 X 1.0LG SS
6	8	061060050000	HEX NUT 5/16-18 W/INSERT SS
7	12	061100049000	WASHER FLAT OS 5/16" SS
8	4	061142150032	BOLT HEX 5/16-18 X 2" SS
9	4	2020043902	SPACER MOTOR MOUNT AQMCII
10	4	2115031700	RUBBER MOUNT 90LB AQM
11	1	20200239002	PLATE, GP MOTOR MOUNT PLATE AQWC II
12	1	1920016590	STRAIN RELIEF 90, .50 BLK W-NUT
13	1	4928402800	CONDUIT .50 FLEX BLK
14	1	1317021969	ELB90 -6 FLARE X 3/8 MPT SS
15	1	5353140903	MANIFOLD HP TRANSDUCER AQMW
16	1	01173818CL	NIPPLE HEX .375 NPT X CLOSE SS
17	1	2317100300	TRANSDUCER 0-2000 PSI 7/16" SAE
18	1	0112072600	ELB90 1/2 MPT X 3/4 BARB NYLON
19	1	1904040600	STRAIN RELIEF 1/2" BLK LT50P
20	4	061110049000	WASHER FENDER .312 SS
21	1	12180511CO	HP PUMP-GP 3.0 GPM LEFTHAND

Refer to drawing on next page.

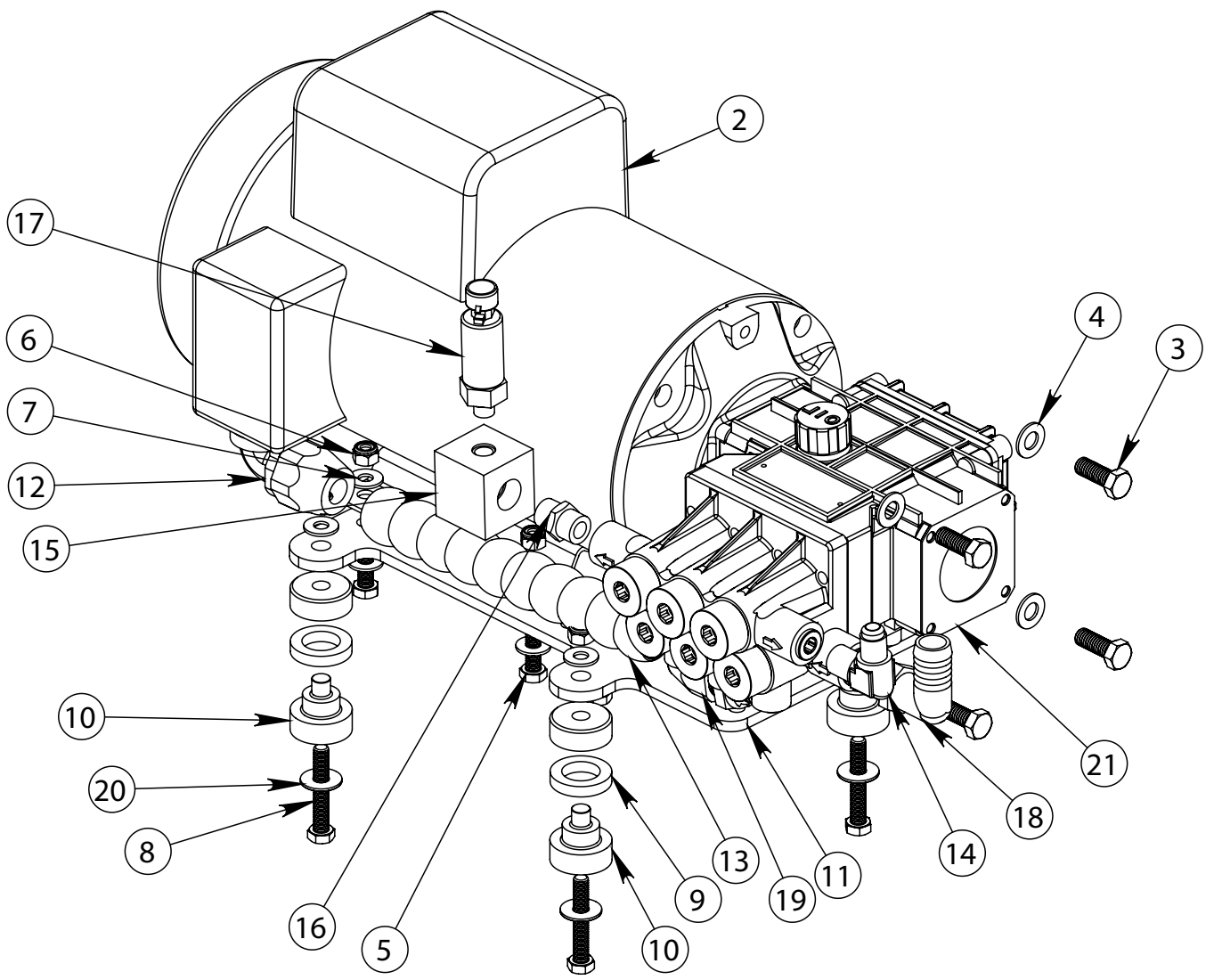

B198000032 MEMBRANE RACK 450-1

ITEM NO.	QTY	PART NO.	DESCRIPTION
1	1	2408132500	VESSEL HIGH PRESSURE 450GPD
2	1	2724011233	MEMBRANE 450GPD W-SEAL
3	2	0520210600	RETAINER PORT MVA AW
4	4	2614014900	O-RING 230 BRINE 3" END PLUG
5	2	2614010100	O-RING 116 PRODUCT
6	1	0101370820	NIPPLE .25 NPT X 2.0 PVC
7	1	2453512402	END PLUG DUAL 3" AW
8	1	2453502403	END PLUG SINGLE 3 AW LONGER
9	6	061162345012	SC SOC CAP 1/4-20 X 3/4 SS
10	1	0204010869	ELB90 1/4 TUBE X 1/4 FNPT PLASTIC
11	1	0312121969	TUBE 1/4 BLACK
12	2	0117410800	NIPPLE HP MVA AW
13	4	2614017900	O-RING 115 INTERCONNECT AW
14	2	1317011769	ELB90 6 FLARE X .25 FPT SS
15	2	1317481969	SWIVEL FITTING 6 SS P
16	2	20201030000	SEGMENT RING AW (SET)
17	2	2432160669	HOSE HP -6P
18	2	2632180426	DECOFELT .125 x 1.25 BLK
19	1	0204690100	REDUCER .375 x .25 JQ
20	1	2220010660	LABEL MEMBRANE SERIAL NO
21	1	2234011260	LABEL INLET (SRC BLUE)
22	1	2234011360	LABEL OUTLET (SRC BLUE)
23	2	061100043000	WASHER FLAT OS 1/4" SS
24	2	061142145012	BOLT HEX 1/4-20 X 3/4 SS
25	4	061161845012	SC ALLEN FLAT 1/4-20 X 3/4 SS
26	2	0520051800	MVA RACK AW SERIES
27	1	0204741800	UNION TEE 3/8 X 3/8 X 3/8 DIV
28	1	0204990200	PLUG .375 JQ
29	2	05202401GR	BRACKET MVA U-CLAMP

Refer to drawing on next page.

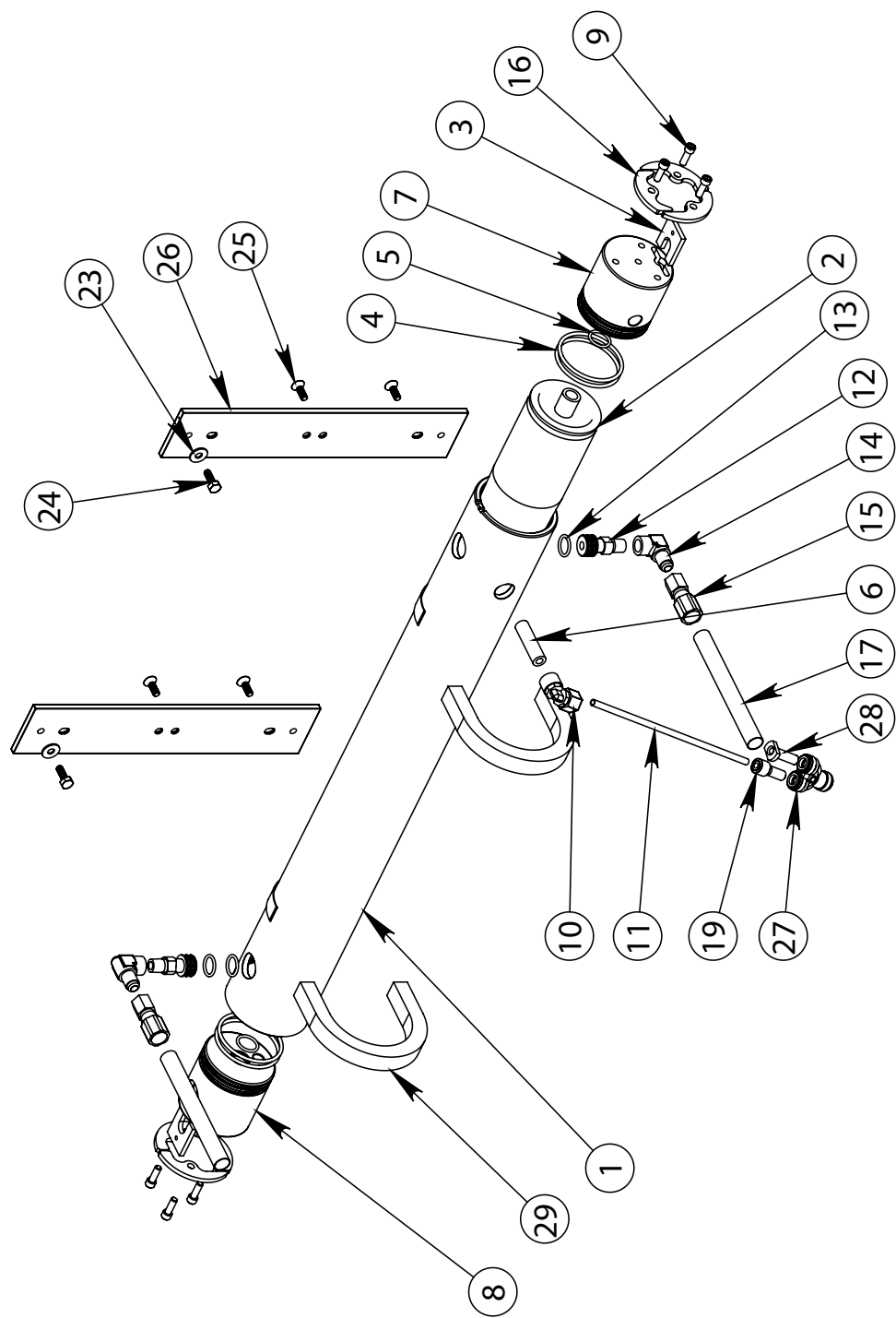

B198000033 MEMBRANE RACK 700-1

ITEM NO.	QTY.	PART NO.	DESCRIPTION
1	1	2408132500-01	VESSEL HIGH PRESSURE 700GPD
2	1	2724011333	MEMBRANE 700GPD W-SEAL
3	2	0520210600	RETAINER PORT MVA AW
4	4	2614014900	O-RING 230 BRINE 3" END PLUG
5	2	2614010100	O-RING 116 PRODUCT
6	1	0101370820	NIPPLE .25 NPT X 2.0 PVC
7	1	2453512402	END PLUG DUAL 3" AW
8	1	2453502403	END PLUG SINGLE 3 AW LONGER
9	6	061162345012	SC SOC CAP 1/4-20 X 3/4 SS
10	1	0204010869	ELB90 1/4 TUBE X 1/4 FNPT PLASTIC
11	1	0312121969	TUBE 1/4 BLACK
12	2	0117410800	NIPPLE HP MVA AW
13	4	2614017900	O-RING 115 INTERCONNECT AW
14	2	1317011769	ELB90 6 FLARE X .25 FPT SS
15	2	20201030000	SEGMENT RING AW (SET)
16	2	2632180426	DECOFELT .125 x 1.25 BLK
17	1	0204690100	REDUCER .375 x .25 JQ
18	1	2220010660	LABEL MEMBRANE SERIAL NO
19	1	2234011260	LABEL INLET (SRC BLUE)
20	1	2234011360	LABEL OUTLET (SRC BLUE)
21	2	061100043000	WASHER FLAT OS 1/4" SS
22	2	061142145012	BOLT HEX 1/4-20 X 3/4 SS
23	4	061161845012	SC ALLEN FLAT 1/4-20 X 3/4 SS
24	2	0520051800	MVA RACK AW SERIES
25	1	0204741800	UNION TEE 3/8 X 3/8 X 3/8 DIV
26	1	0204990200	PLUG .375 JQ
27	2	05202401GR	BRACKET MVA U-CLAMP

Refer to drawing on next page.

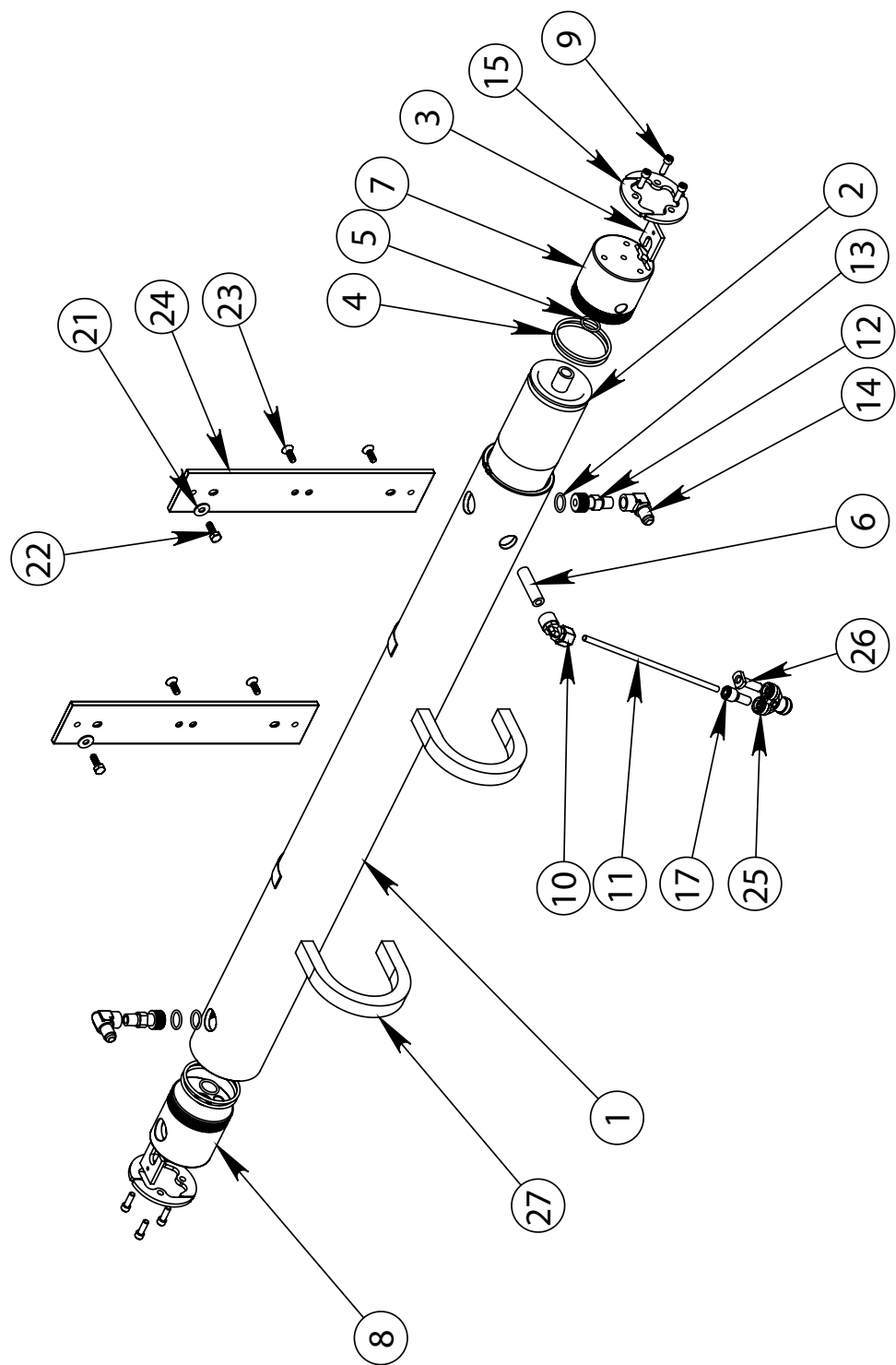

B198000034 MEMBRANE RACK 900-1

ITEM NO.	QTY.	PART NO.	DESCRIPTION
1	1	2408132500-02	VESSEL HIGH PRESSURE 900GPD
2	1	2724011433	MEMBRANE 900GPD W/SEAL
3	2	0520210600	RETAINER PORT MVA AW
4	4	2614014900	O-RING 230 BRINE 3" END PLUG
5	2	2614010100	O-RING 116 PRODUCT
6	1	0101370820	NIPPLE .25 NPT X 2.0 PVC
7	1	2453512402	END PLUG DUAL 3" AW
8	1	2453502403	END PLUG SINGLE 3 AW LONGER
9	6	061162345012	SC SOC CAP 1/4-20 X 3/4 SS
10	1	0204010869	ELB90 1/4 TUBE X 1/4 FNPT PLASTIC
11	1	0312121969	TUBE 1/4 BLACK
12	2	0117410800	NIPPLE HP MVA AW
13	4	2614017900	O-RING 115 INTERCONNECT AW
14	2	1317011769	ELB90 6 FLARE X .25 FPT SS
15	2	20201030000	SEGMENT RING AW (SET)
16	2	2632180426	DECOFELT .125 x 1.25 BLK
17	1	0204690100	REDUCER .375 x .25 JQ
18	1	2220010660	LABEL MEMBRANE SERIAL NO
19	1	2234011260	LABEL INLET (SRC BLUE)
20	1	2234011360	LABEL OUTLET (SRC BLUE)
21	2	061100043000	WASHER FLAT OS 1/4" SS
22	2	061142145012	BOLT HEX 1/4-20 X 3/4" SS
23	4	061161845012	SC ALLEN FLAT 1/4-20 X 3/4" SS
24	2	0520051800	MVA RACK AW SERIES
25	1	0204741800	UNION TEE 3/8 X 3/8 X 3/8 DIV
26	1	0204990200	PLUG .375 JQ
27	2	05202401GR	BRACKET MVA U-CLAMP

Refer to drawing on next page.

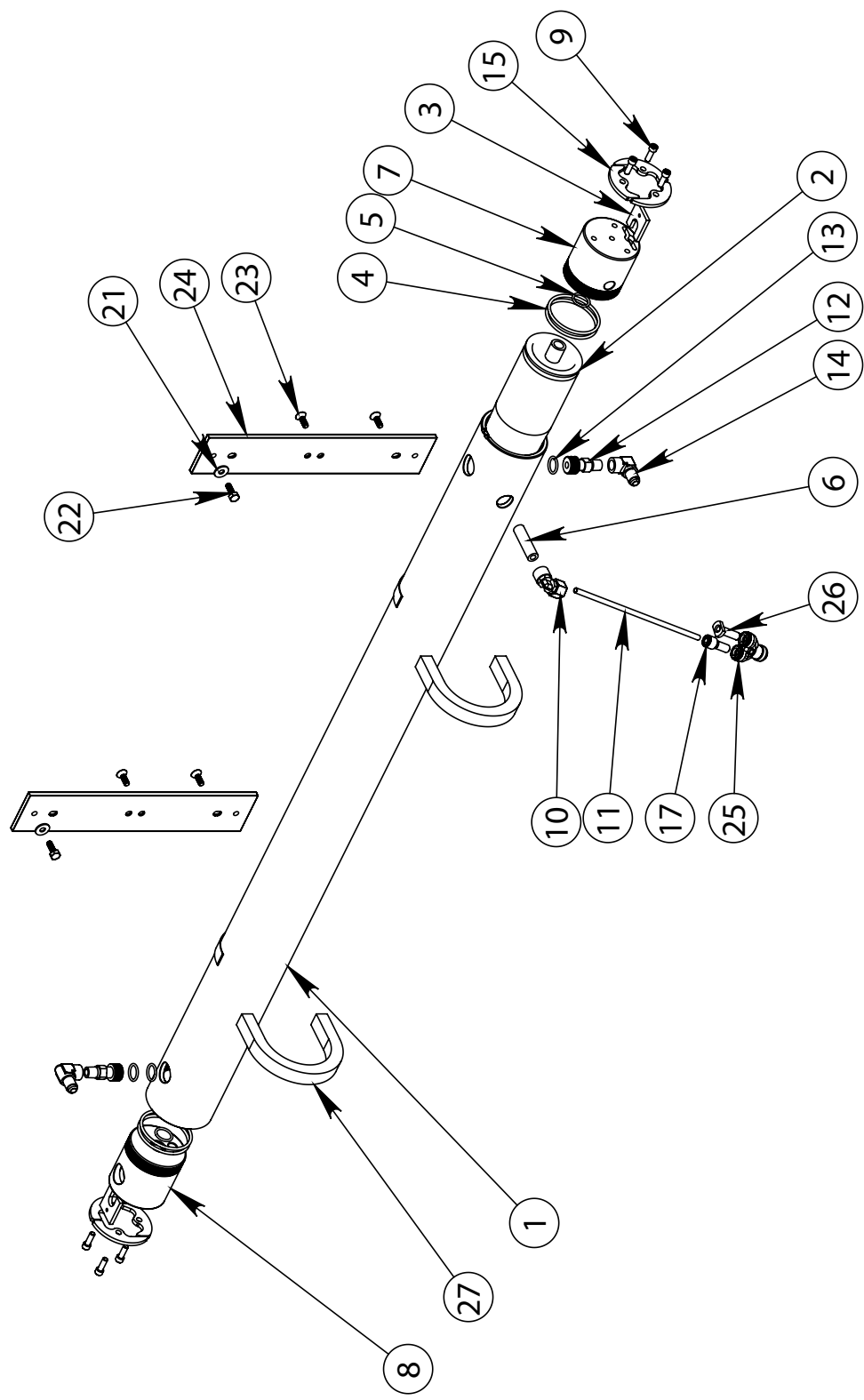

B198000035 MEMBRANE RACK 900-2

ITEM NO.	QTY.	PART NUMBER	DESCRIPTION
1	2	2408132500	VESSEL HIGH PRESSURE 450GPD
2	2	2724011233	MEMBRANE 450GPD W-SEAL
3	4	0520210600	RETAINER PORT MVA AW
4	8	2614014900	O-RING 230 BRINE 3" END PLUG
5	4	2614010100	O-RING 116 PRODUCT
6	2	0101370820	NIPPLE .25 NPT X 2.0 PVC
7	2	2453512402	END PLUG DUAL 3" AW
8	2	2453502403	END PLUG SINGLE 3 AW LONGER
9	12	061162345012	SC SOC CAP 1/4-20 X 3/4 SS
10	2	0204010869	ELB90 1/4 TUBE X 1/4 FNPT PLASTIC
11	2	0312121969	TUBE 1/4 BLACK
12	2	0117410800	NIPPLE HP MVA AW
13	8	2614017900	O-RING 115 INTERCONNECT AW
14	2	1317011769	ELB90 6 FLARE X .25 FPT SS
15	2	1317481969	SWIVEL FITTING 6 SS P
16	4	20201030000	SEGMENT RING AW (SET)
17	2	2432160669	HOSE HP -6P
18	4	2632180526	DECOFELT 1/16 X 1 BLK ADH BACK
19	2	2220010660	LABEL MEMBRANE SERIAL NO
20	2	2234011260	LABEL INLET (SRC BLUE)
21	2	2234011360	LABEL OUTLET (SRC BLUE)
22	1	2417430800	INTERCONNECT MVA SS AW
23	2	061100043000	WASHER FLAT OS 1/4" SS
24	2	061142145016	BOLT HEX .25-20 X 1.0 SS
25	8	061161845012	SC ALLEN FLAT 1/4-20 X 3/4 SS
26	2	0520051800	MVA RACK AW SERIES
27	4	05202401GR	BRACKET MVA U-CLAMP
28	1	0204741800	UNION TEE 3/8 X 3/8 X 3/8 DIV
29	1	0204690100	REDUCER .375 x .25 JQ
30	1	0204990200	PLUG .375 JQ

Refer to drawing on next page.

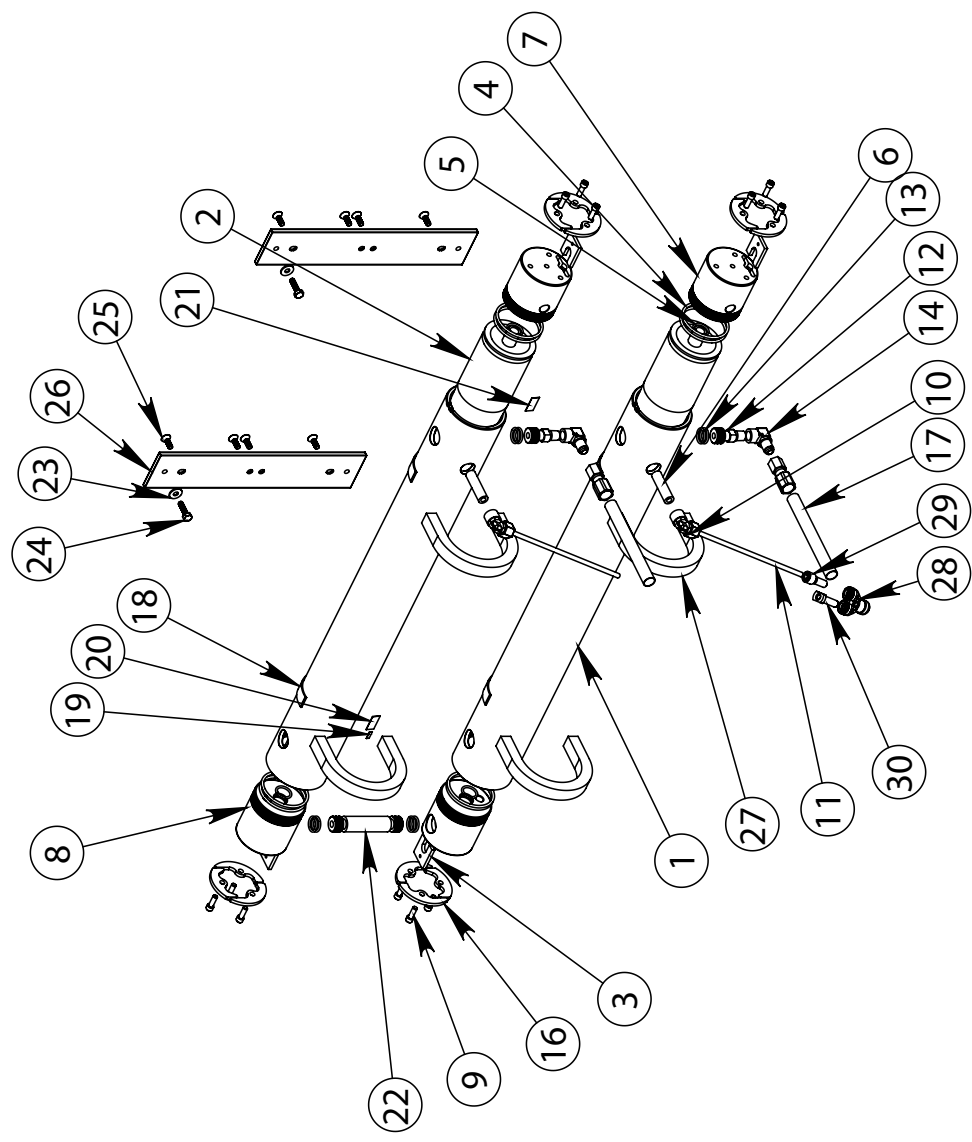

B198000036 MEMBRANE RACK 1400-2

ITEM NO.	QTY.	PART NO.	DESCRIPTION
1	2	2408132500-01	VESSEL HIGH PRESSURE 700GPD
2	2	2724011333	MEMBRANE 700GPD W-SEAL
3	4	0520210600	RETAINER PORT MVA AW
4	8	2614014900	O-RING 230 BRINE 3" END PLUG
5	4	2614010100	O-RING 116 PRODUCT
6	2	0101370815	NIPPLE 1/4 NPT X 1 1/2 PVC
7	2	2453512402	END PLUG DUAL 3" AW
8	2	2453502403	END PLUG SINGLE 3 AW LONGER
9	12	061162345012	SC SOC CAP 1/4-20 X 3/4 SS
10	2	0204010869	ELB90 1/4 TUBE X 1/4 FNPT PLASTIC
11	2	0312121969	TUBE 1/4 BLACK
12	2	0117410800	NIPPLE HP MVA AW
13	8	2614017900	O-RING 115 INTERCONNECT AW
14	2	1317011769	ELB90 6 FLARE X .25 FPT SS
15	4	20201030000	SEGMENT RING AW (SET)
16	4	2632180526	DECOFELT 1/16 X 1 BLK ADH BACK
17	2	2220010660	LABEL MEMBRANE SERIAL NO
18	2	2234011260	LABEL INLET (SRC BLUE)
19	2	2234011360	LABEL OUTLET (SRC BLUE)
20	1	2417430800	INTERCONNECT MVA SS AW
21	2	061100043000	WASHER FLAT OS 1/4" SS
22	2	061142145016	BOLT HEX .25-20 X 1.0 SS
23	8	061161845012	SC ALLEN FLAT 1/4-20 X 3/4 SS
24	2	0520051800	MVA RACK AW SERIES
25	4	05202401GR	BRACKET MVA U-CLAMP
26	1	0204741800	UNION TEE 3/8 X 3/8 X 3/8 DIV
27	1	0204690100	REDUCER .375 x .25 JQ
28	1	0204990200	PLUG .375 JQ

Refer to drawing on next page.

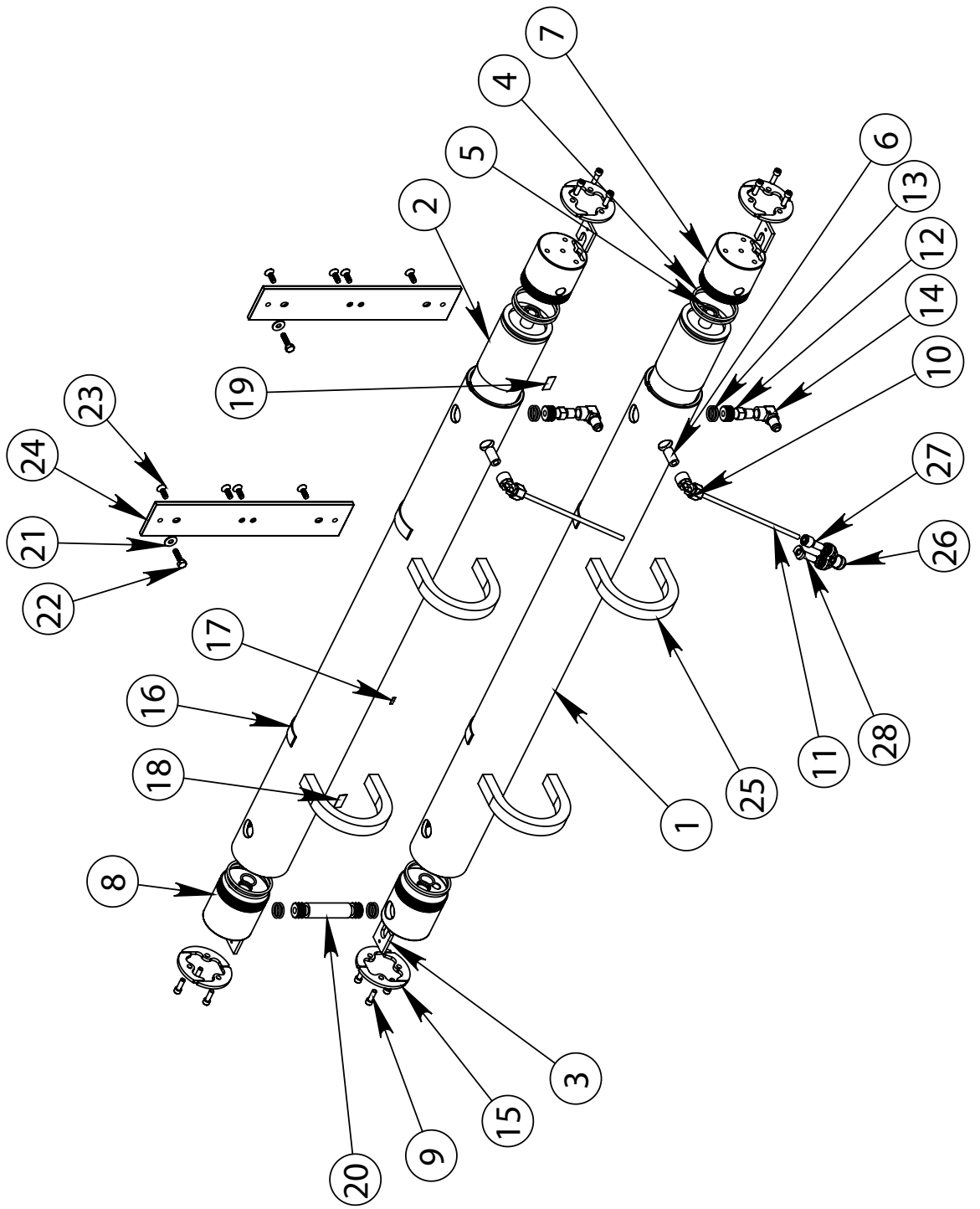

B198000037 MEMBRANE RACK 1800-2

ITEM NO.	QTY.	PART NO.	DESCRIPTION
1	2	2408132500-02	VESSEL HIGH PRESSURE 900GPD
2	2	2724011433	MEMBRANE 900GPD W/SEAL
3	4	0520210600	RETAINER PORT MVA AW
4	8	2614014900	O-RING 230 BRINE 3" END PLUG
5	4	2614010100	O-RING 116 PRODUCT
6	2	0101370815	NIPPLE 1/4 NPT X 1 1/2 PVC
7	2	2453512402	END PLUG DUAL 3" AW
8	2	2453502403	END PLUG SINGLE 3 AW LONGER
9	12	061162345012	SC SOC CAP 1/4-20 X 3/4 SS
10	2	0204010869	ELB90 1/4 TUBE X 1/4 FNPT PLASTIC
11	2	0312121969	TUBE 1/4 BLACK
12	2	0117410800	NIPPLE HP MVA AW
13	8	2614017900	O-RING 115 INTERCONNECT AW
14	2	1317011769	ELB90 6 FLARE X .25 FPT SS
15	4	20201030000	SEGMENT RING AW (SET)
16	4	2632180526	DECOFELT 1/16 X 1 BLK ADH BACK
17	2	2220010660	LABEL MEMBRANE SERIAL NO
18	2	2234011260	LABEL INLET (SRC BLUE)
19	2	2234011360	LABEL OUTLET (SRC BLUE)
20	1	2417430800	INTERCONNECT MVA SS AW
21	2	061100043000	WASHER FLAT OS 1/4"SS
22	2	061142145016	BOLT HEX .25-20 X 1.0 SS
23	8	061161845012	SC ALLEN FLAT 1/4-20 X 3/4 SS
24	2	0520051800	MVA RACK AW SERIES
25	4	05202401GR	BRACKET MVA U-CLAMP
26	1	0204690100	REDUCER .375 x .25 JQ
27	1	0204741800	UNION TEE 3/8 X 3/8 X 3/8 DIV
28	1	0204990200	PLUG .375 JQ

Refer to drawing on next page.

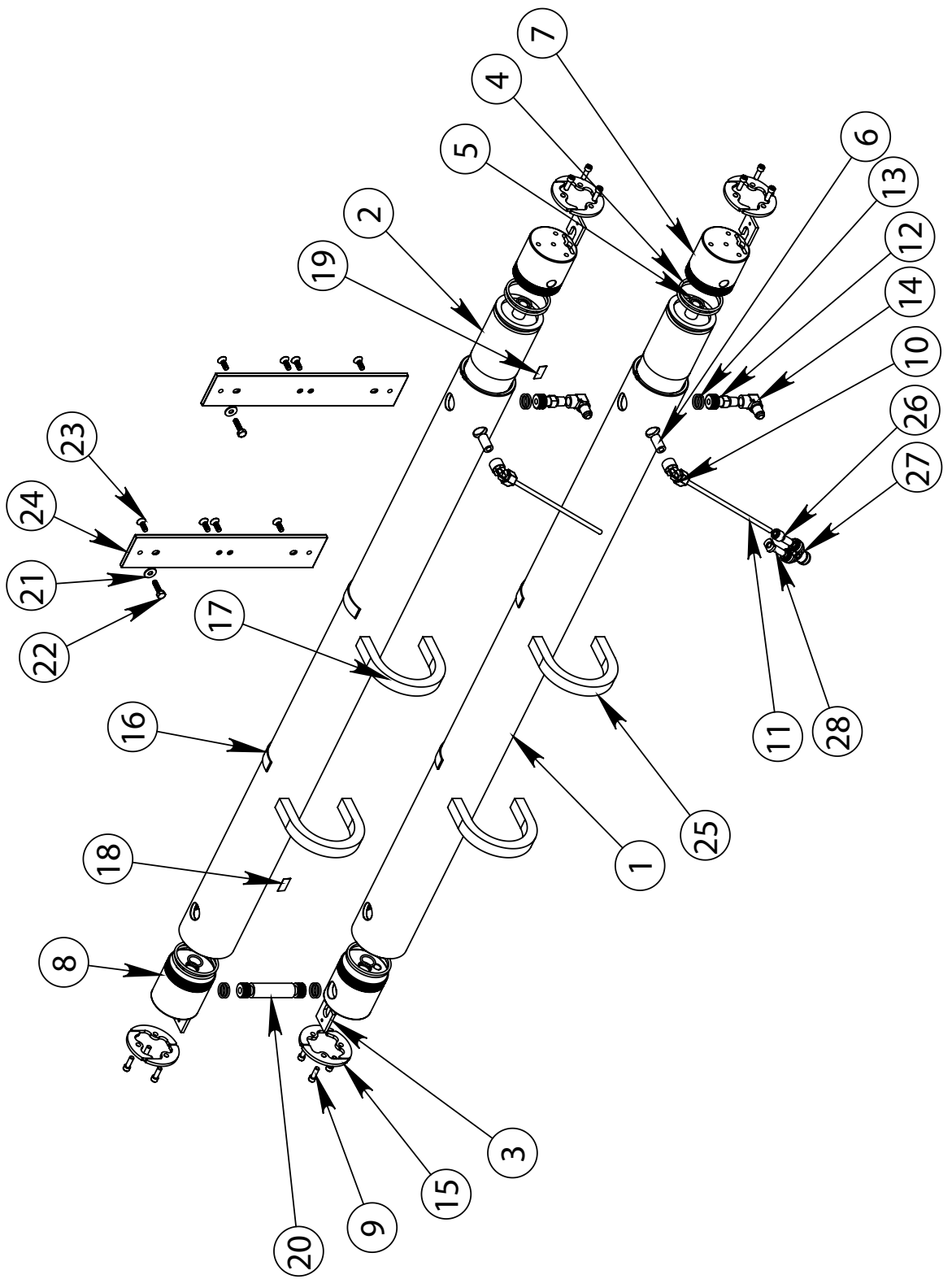

B476160002 BACK PRESSURE REGULATOR ASSY

ITEM NO.	QTY.	PART NO.	DESCRIPTION
1	1	B476160002	BACK PRESSURE REGULATOR ASSY AQMC II (INCLUDES P/N 2-8)
2	1	1417017896	VALVE PRESS REGULATOR-AS
3	1	B079400004	BPR GEAR ASSY AQM II
4	1	0117230819	ELB90 ST 1/4 MPT X 1/4 FPT SS
5	1	0204022369	ELB90 1/2 TUBE X 1/4 MPT PLASTIC
6	1	1317011769	ELB90 6 FLARE X .25 FPT SS
7	1	3421020100	COUPLER BACK PRESSURE REG-AQM
8	1	0117370815	NIPPLE 1/4 NPT X 1.5 SS

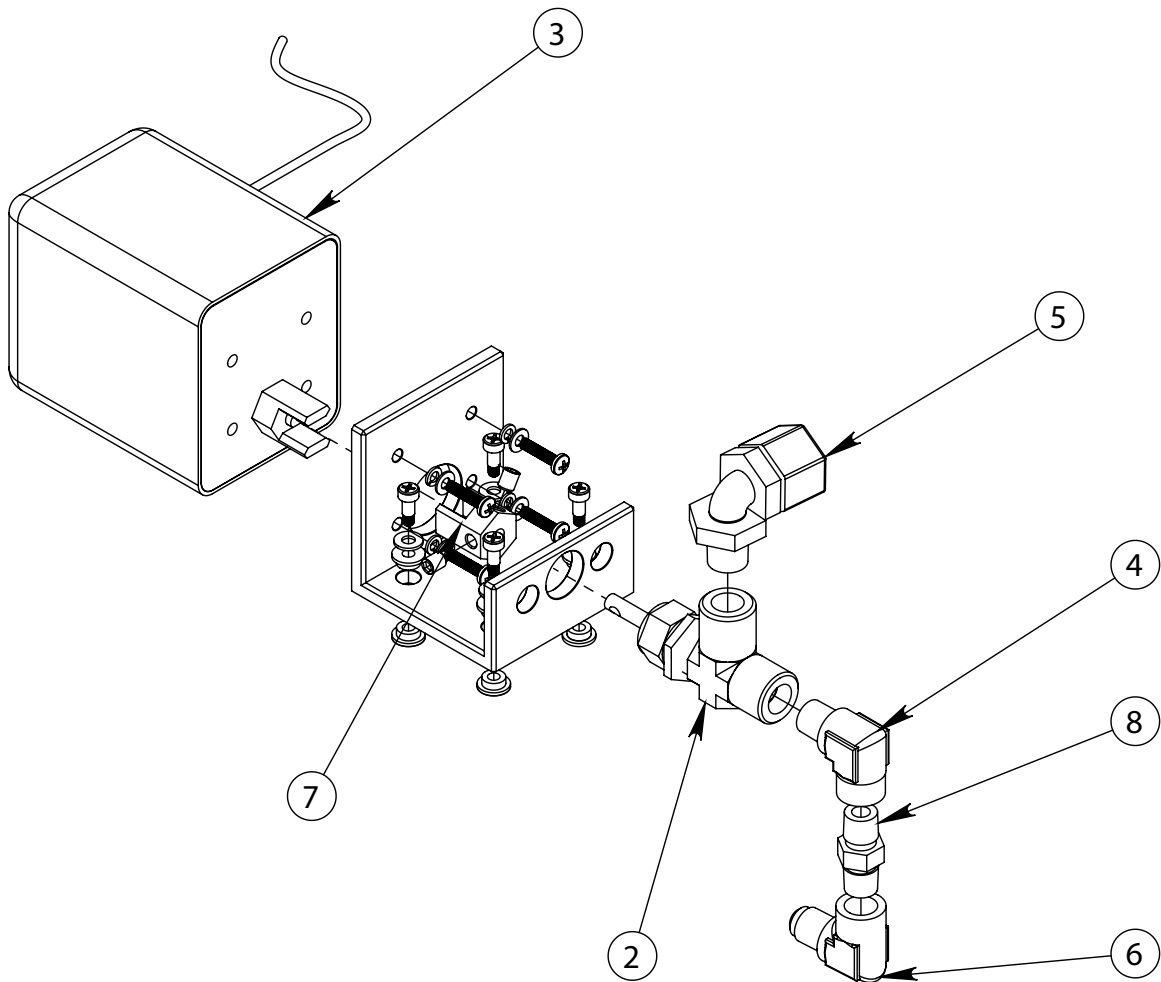

B480160002 WET PLATE ASSY AQMC III

ITEM	PART NUMBER	DESCRIPTION	QTY
*1	B476160004	BPR CONNECTION, AQMXL,ASSY	1
2	14012007	MAMANIFOLD, AQM 1-4 DV, NYL, PRESS, LOW, 6X1.5X3	1
3	14012044	MANIFOLD, PROB, NYL, PRESS, LOW, 6X1.5X2	1
4	11026520AO	Turbo-Flowmeter	1
5	11026920AO	FLOWMETER IN-LINE .53-7.9GPM	1
6	1401096100	VALVE SOLENOID 12VDC	1
7	20-4096	PROBE, CONDUCTIVITY, 5-WIRE, 5 LONG CABLE	1
8	2020083900	PLATE WATER AQUAMATIC II	1
9	3131680298	PLUG CONNECTOR DIN 3-PIN	1
10	0101551883	ADAPT .375 SL x .375 FIPT PVC	1
11	0112652000	ADAP 0.38MPTX.75BARB NYL	1
12	0204012469	ELBOW,PP,1/2 ODx3/8 FT	1
13	0204021869	ELBOW,PP,3/8 ODx3/8 MT	2
14	0501164800	PIPE SUPPORT .375	1
15	061060026000	NUT,HEX,8-32 W-INSERT SS	1
16	061080023000	WASHER,FLAT,#8",SS	1
17	061080028000	WASHER FLAT #10 SS	6
18	061160526048	SC 8-32 x 3.00 SS	2
19	061160626012	SC PHIL PAN #8-32 x .75 SS	1
20	061160630012	SC PHIL PAN 10-24 X .75 SS	6
21	0301094100	PIPE PVC SCH 80 .375 IN x 3	1
22	0101341883	PLUG 0.375 MT	3
23	4942220809	WIRE 18GA 2COND BLUE FLEX C	4 FT

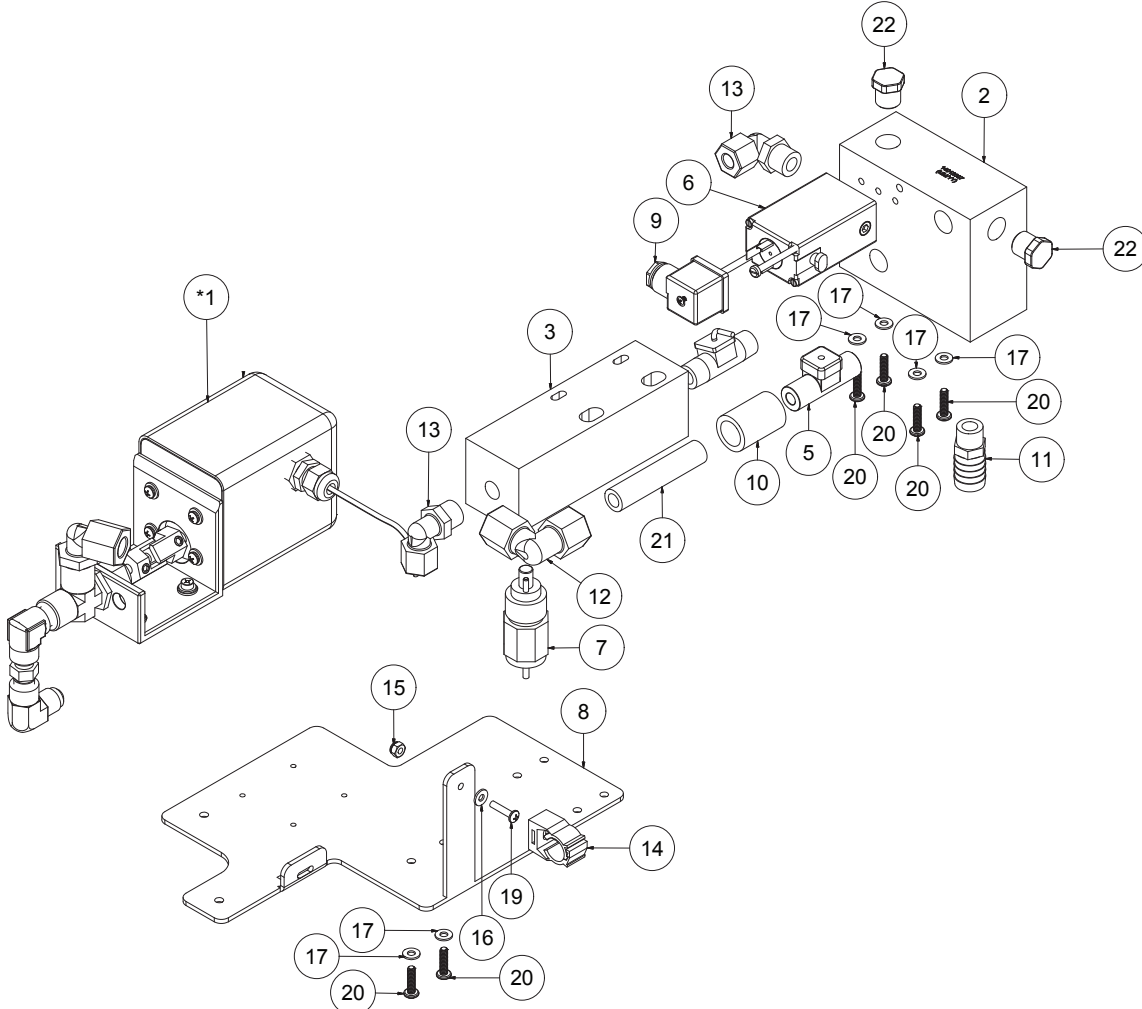

B502160001 MANIFOLD ASSY AQMC / AQW DX RADIAL AXIAL PUMP

ITEM NO.	QTY.	PART NO.	DESCRIPTION
1	1	B502160001	MANIFOLD ASSY AQMC / AQW DX DX (INCLUDES P/N 2-6)
2	1	5301400801	MANIFOLD LP PICKUP, AQM II
3	1	2317100200	TRANSDUCER 0-200 PSI 7/16" SAE
4	2	01126526DG	ADAP 1/2 MPT X 3/4 BARB NYLON
5	1	0117349400	PLUG .43-20 SS BOSS
6	1	0204090869	CONN 1/4 TUBE X 1/4 MPT PLASTIC

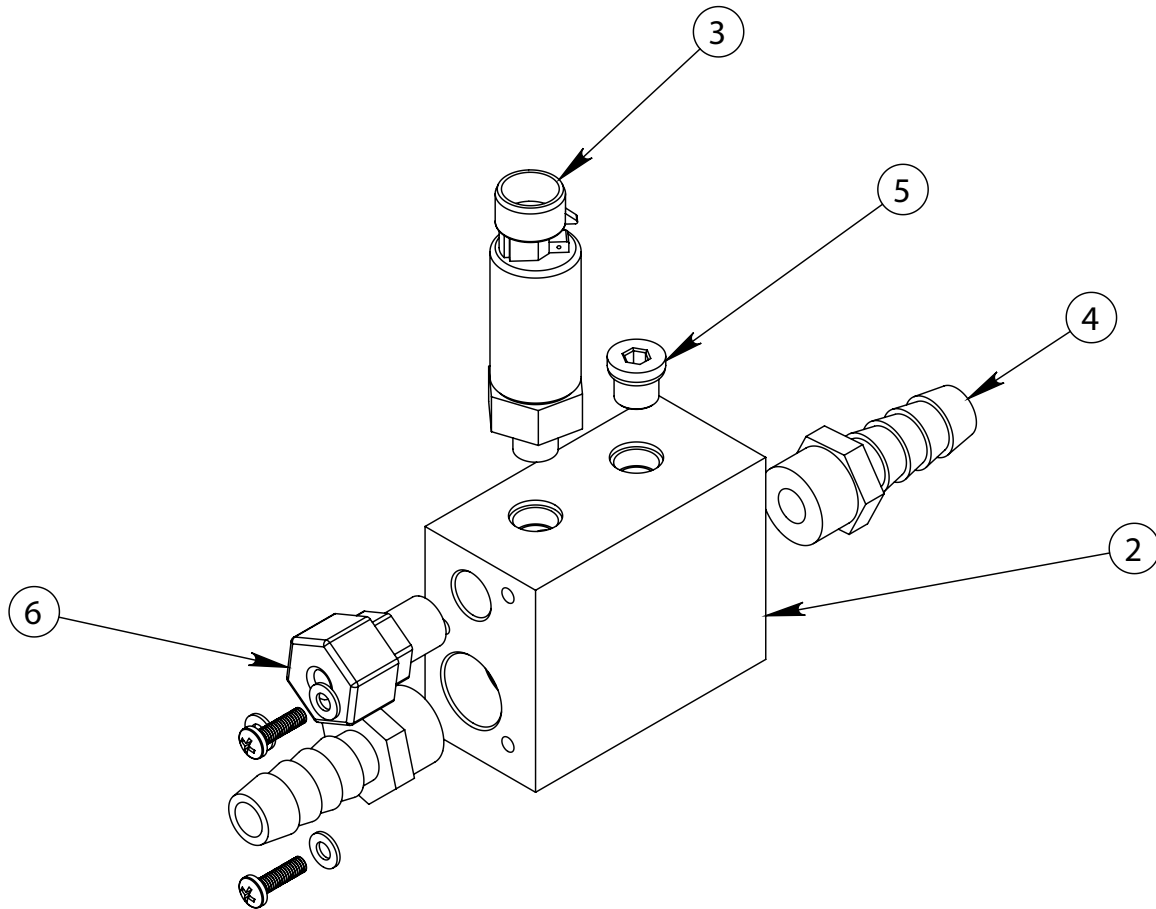

B502160002 MANIFOLD LP ASSY AQMC/AQW DX GP PUMP

ITEM NO.	QTY.	PART NO.	DESCRIPTION
1	1	B502160002	MANIFOLD LP ASSY AQMC / AQW DX (INCLUDES P/N 2-5)
2	2	2317100200	TRANSDUCER 0-200 PSI 7/16" SAE
3	2	01126526DG	ADAP 1/2 MPT X 3/4 BARB NYLON
4	1	5301400801	MANIFOLD LP PICKUP, AQM II
5	1	0204090869	CONN 1/4 TUBE X 1/4 MPT PLASTIC

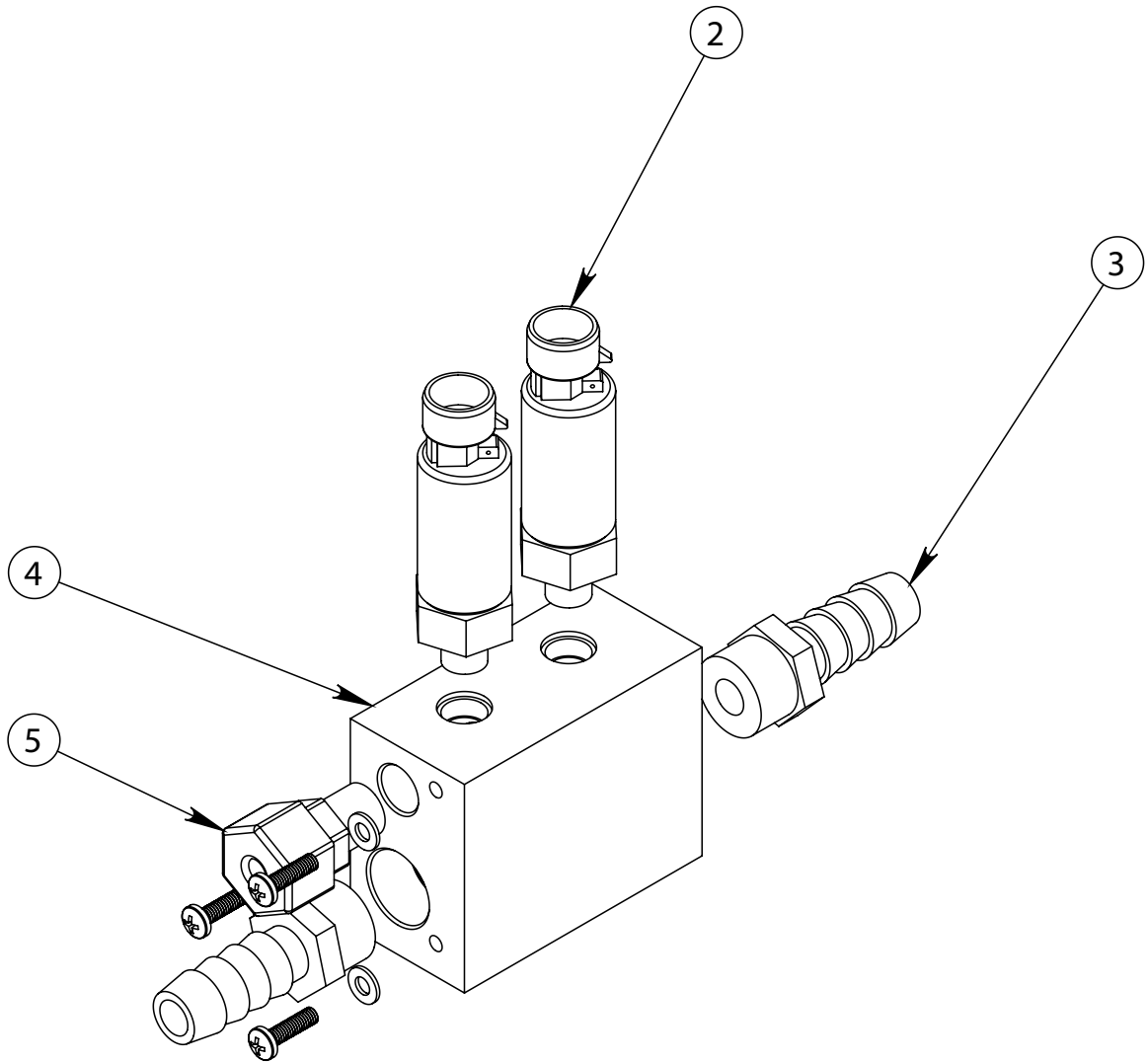

B5262000CV UV STERILIZER 12VDC 2GPM

BILL OF MATERIAL (B.O.M.)			
ITEM NO.	FILE/DWG. NAME	DESCRIPTION	QTY.
1	40000306CV	UV STERILIZER 2 GPM 12VDC	1
2	05011647AI	SUPPORT,PIPE,2.00	2
3	0204091869	FITTING,PP,3/8 ODx3/8 MT	1
4	0254011000	ELB90 0.25 MPT X 0.50BARB NY	2
5	05181432AA	CLAMP,HOSE,SS,1/2"	4
6	061100043000	WASHER FLAT OS .25 SS	2
7	061142145020	SCREW,HEX HEAD,.25-20x1-1/4",SS	2
8	061182143024	SC LAG 0.25 X 1.50 SS	2
9	065070045000	NUT HEX .25-20 FLANGED	2
10	2614019000	O-RING 212 QUARTZ SLEEVE	2
11	B651830001A	OWNERS MANUAL QUICK INSTALLATION UV LIGHT SP SERIES	1

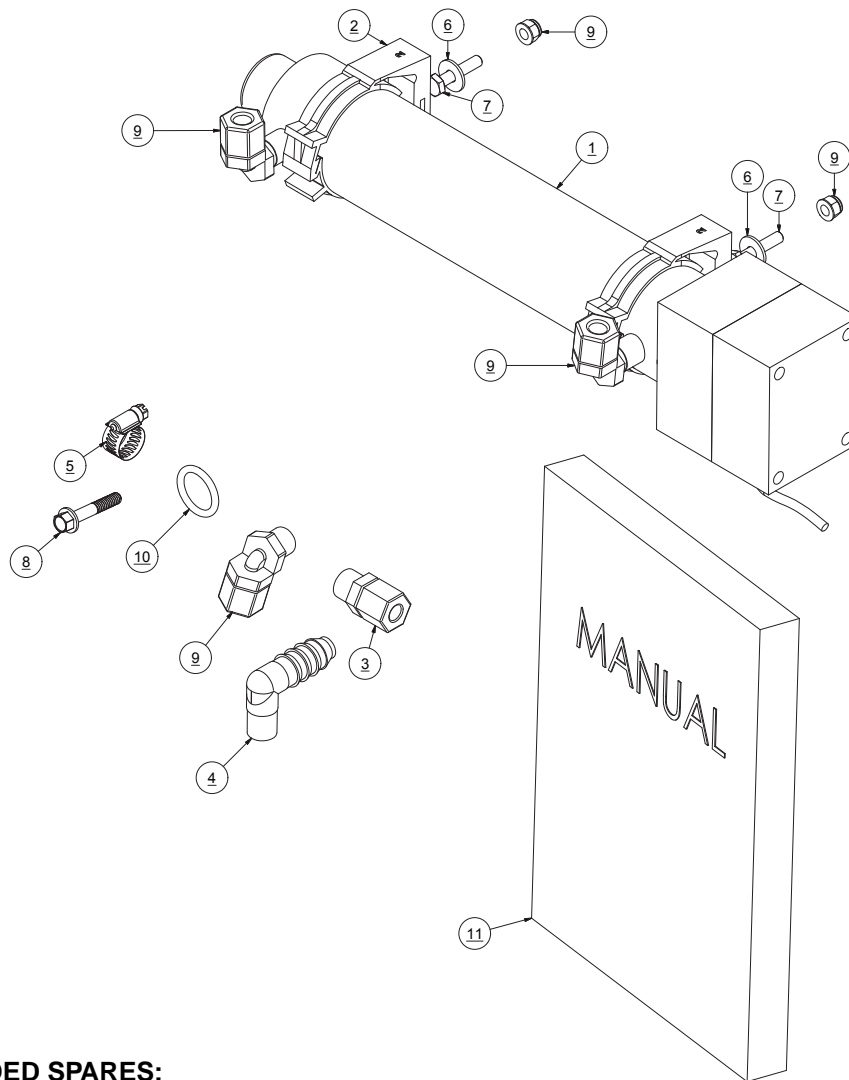

RECOMMENDED SPARES:

QTY.	PART NUMBER	DESCRIPTION
1	40000100CV	UV LAMP 2 GPM

B591120001 CLEAN AND RINSE KIT

ITEM NO.	QTY.	PART NUMBER	DESCRIPTION
1	2	14011334AR	VALVE 3-WAY BALL 3/4 MPT
2	4	0101063783	ELB90 .75 FNPT X .75 BARB PVC
3	4	0501164200	PIPE SUPPORT 1 1/8" #36
4	2	0101613783	ADAP 3/4 FPT X 3/4 BARB PVC
5	12	05181434AA	HOSE CLAMP 3/4" SS

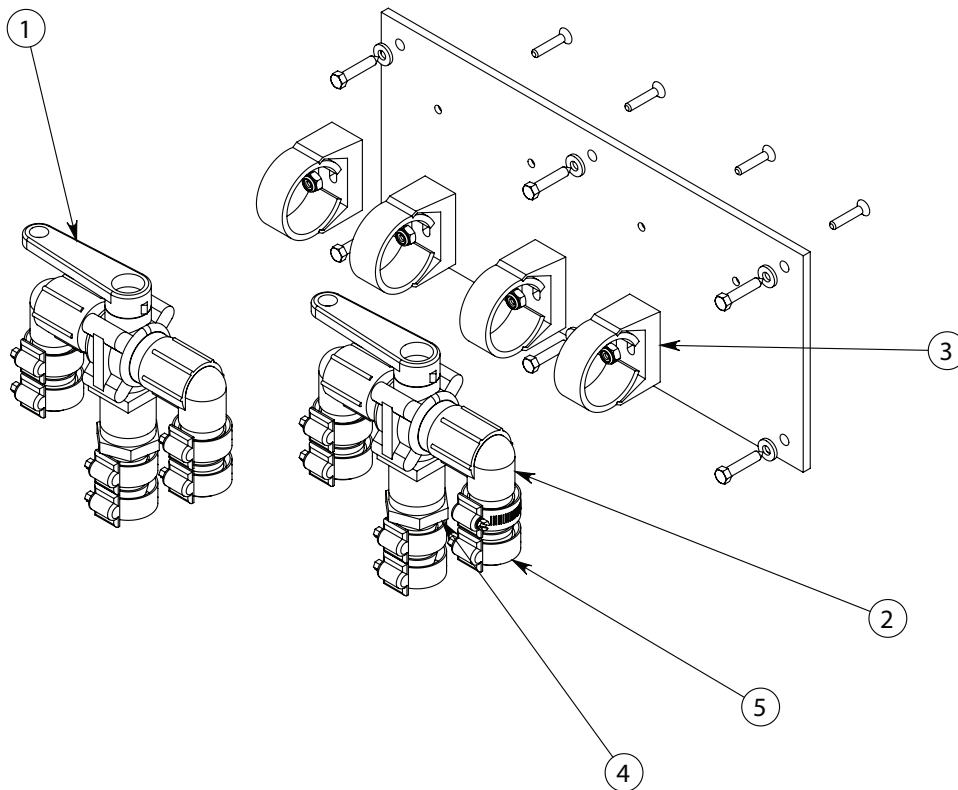

VALVE CONNECTIONS

VALVE CONNECTIONS:

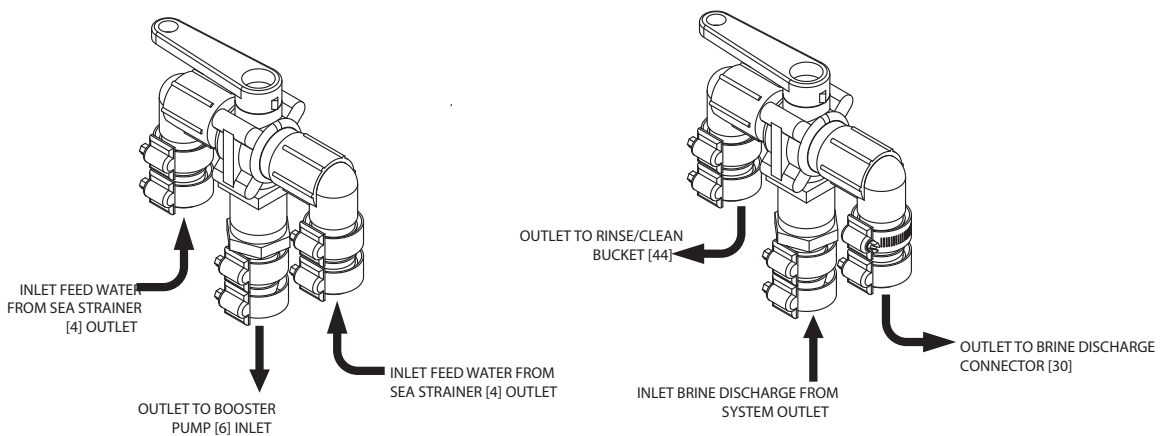

61012017 KIT, CON RL,HMI,7 IN, AQMC-AWDXC

BILL OF MATERIAL (B.O.M.)			
ITEM	PART NUMBER	DESCRIPTION	QTY
1	90012013	BOARD,CONTROLLER,5X 7,PLC,PROGRAM&WIFI,PARKER BRAND	1
2	90012015	HMI,DISPLAY,7 IN PROGRAMMED	1
3	90012289	DONGLE,HMI,RS485,POWER,AQ	1
4	90012014	CONVERTER,12V TO 24V,HMI	1
5	11012072	BRACKET,FRONT COVER,HMI,AQM	1
6	1904010643	STRAIN RELIEF 3444 BLK	1
8	061160620006	SC PHIL PAN A #6 X .375 SS	6
9	061080018000	WASHER FLAT #6 SS	6
10	065080028000	WASHER FLAT #10 NYLON	4
11	061170628016	SC PHIL PAN A #10 X 1 SS	4
12	11012092	BRACKET, MOUNT, CONTOLLER, IOT,AQMC-AWDXC	1
13	067272720004	STANDOFF HEX #6-32 X .25 M X F	6

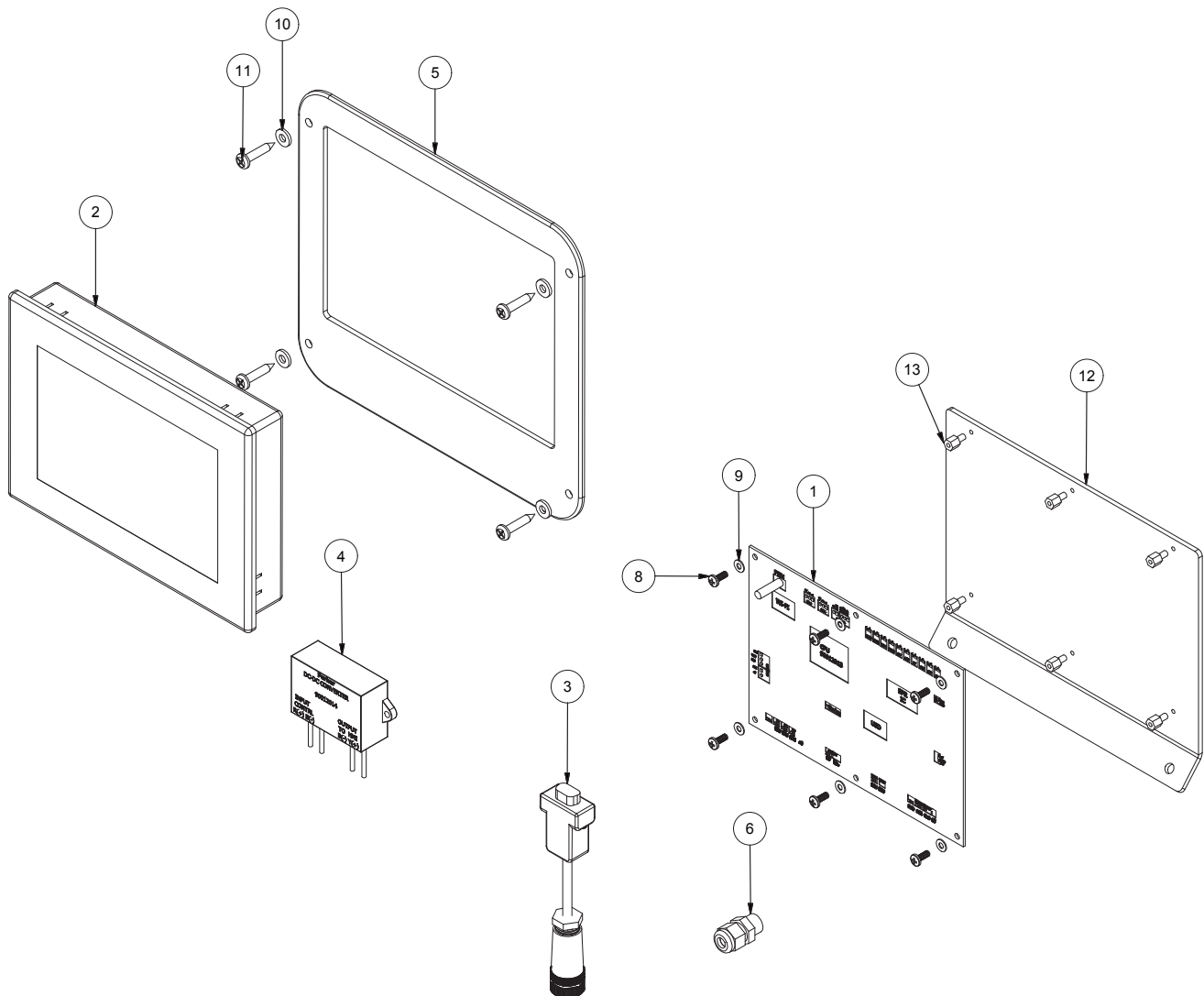

B598000008 FRESH WATER FLUSH (0.50 INCH)

ITEM NO.	QTY.	PART NO.	DESCRIPTION
1	1	0713020873	FILTER HOUSING 1/2 X 10"
2	1	0803004773	CHARCOAL FILTER 10 IN
3	1	14172105AT	VALVE CHECK .25 MNPT SS
4	1	0204091769	CONN 3/8 TUBE X 1/4 MPT PLASTIC
5	1	1401095998	VALVE SOLENOID 12VDC AED/CSFE
6	1	0101340883	PLUG 1/4 MPT PVC
7	1	3131680298	PLUG CONNECTOR DIN 3-PIN
8	1	20200402102	SINGLE FILTER BRACKET
9	4	061172143016	SC HEX "A" 1/4 X 1.0 SS
10	4	061100043000	WASHER FLAT OS 1/4"SS
11	4	065080023000	WASHER FLAT #8 NYLON
12	1	0101423783	TEE .75 FNPT x .75 FNPT x .75 FNPT PVC
13	2	0101653783	ADAP 3/4 MPT X 3/4 BARB PVC
14	1	0501164200	PIPE SUPPORT 1 1/8" #36
15	1	0501164500	PIPE SUPPORT 1 1/4"
16	1	01013737CL	NIPPLE .75 NPT X CLOSE PVC
17	1	14012118AR	VALVE CHECK .75 FNPT WITH VITO
18	8	061170628016	SC PHIL PAN "A" 10 X 1 SS
19	8	065080028000	WASHER FLAT #10 NYLON
20	2	061161626012	SC PHIL FLAT 8-32 X 3/4 SS
21	2	061060026000	NUT HEX 8-32 W/INSERT SS
22	1	2020040002	BRACKET CHECK VALVE FWF
23	1	0204011769	ELB90 3/8 TUBE X 1/2 MPT PLAST
24	2	0204011769	ELB90 .375 TUBE x .25 FNPT PLASTIC
25	4	05181432AA	HOSE CLAMP 1/2" SS
26	1	0312123569	TUBE .375 BLACK
27	4	061170623008	SC PHIL PAN "B" #8 X 1/2" SS
28	1	0204092069	CONN 3/8 TUBE X 3/4 MPT PLASTIC

Refer to drawing on next page.

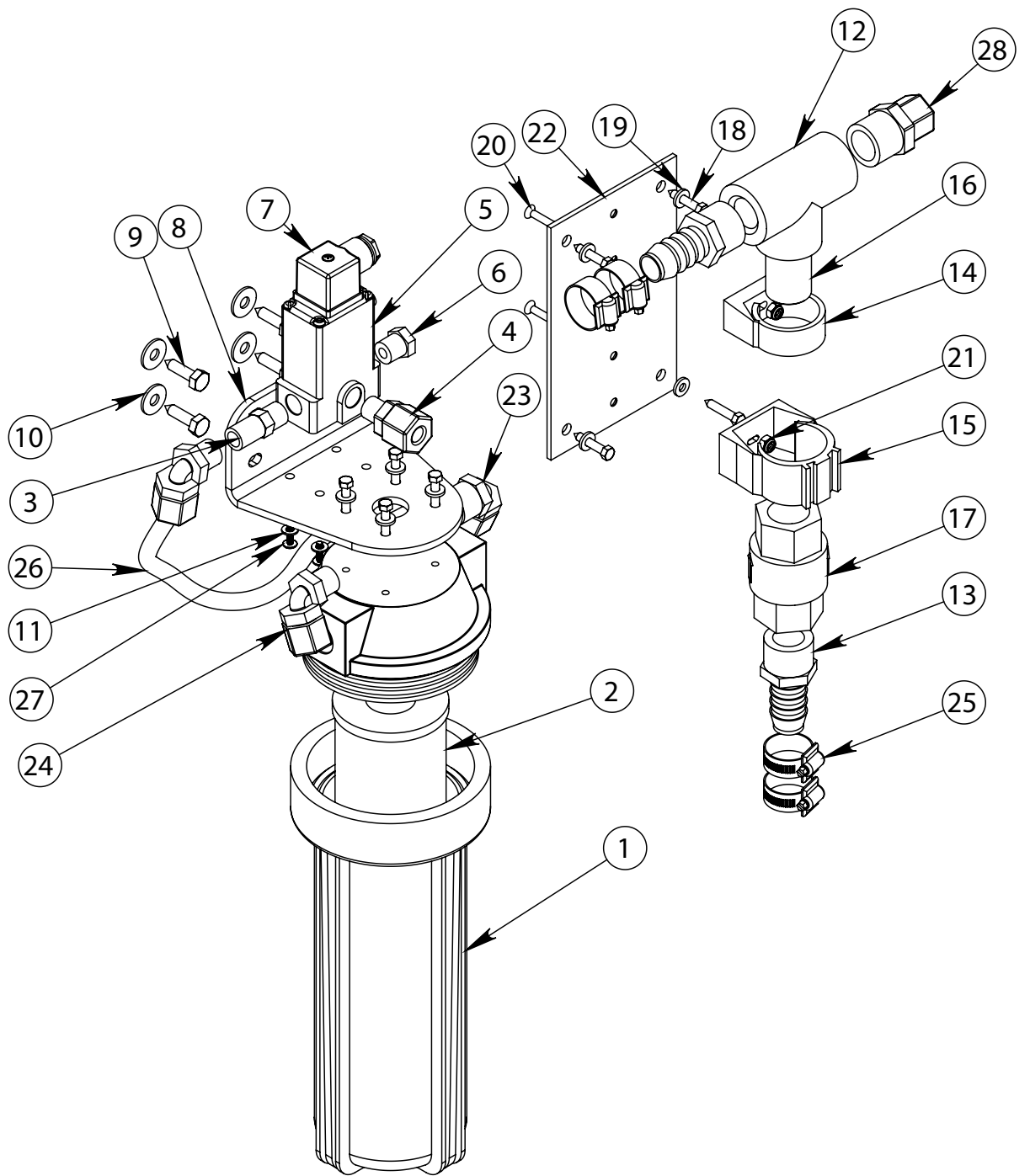

B610140004 NMEA 2000 ENABLED

ITEM NO.	QTY.	PART NO.	DESCRIPTION
1	1	31316809MT	MICRO CAP
2	1	31316801MT	MICRO BULKHEAD FEED-THRU ASSY
3	1	31316812MT	MICRO SINGLE ENDED CORDSET MALE

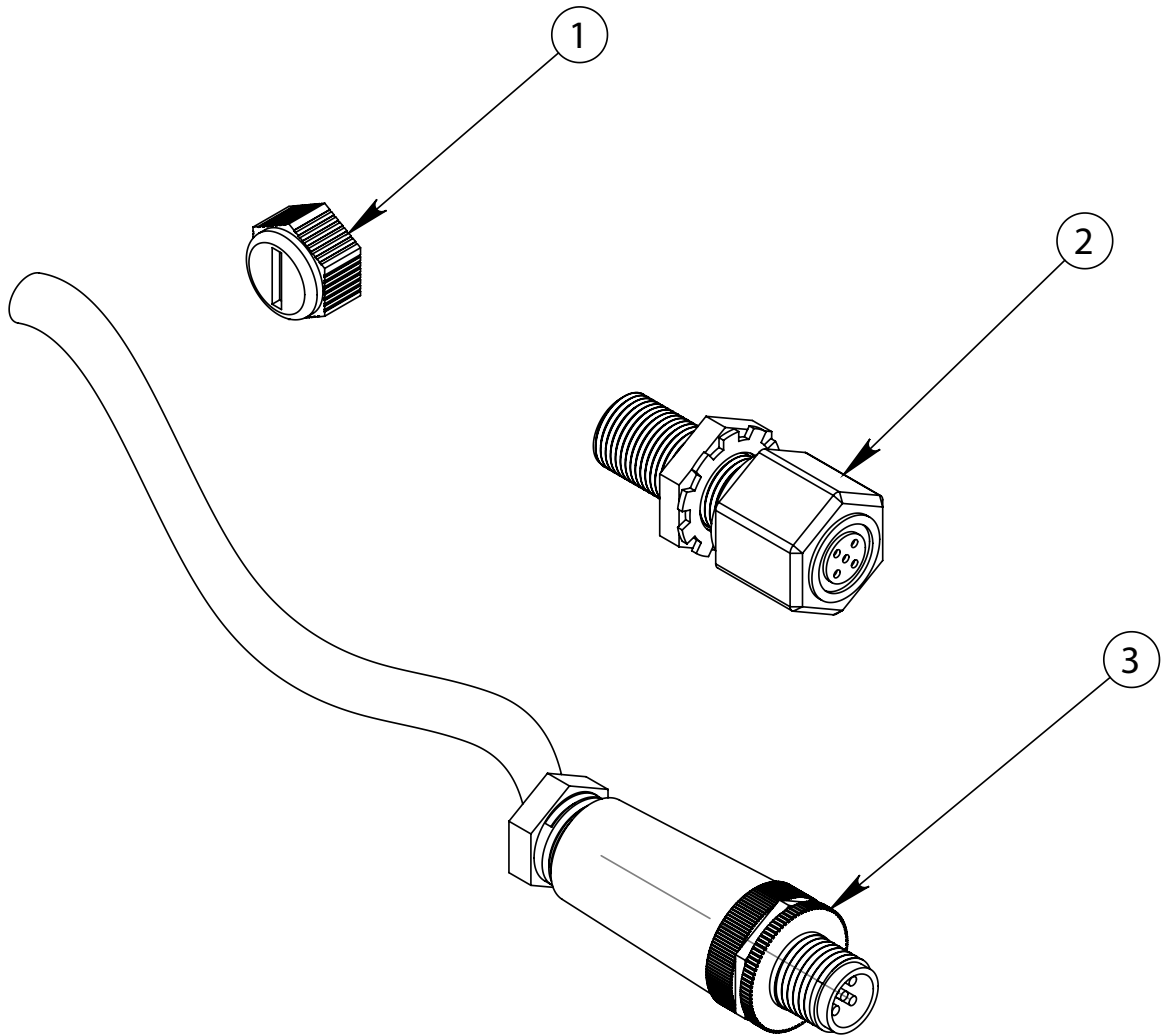

Exploded Parts View

61012029 REMOTE KIT, 100FT CABLE, PARKER

BILL OF MATERIAL (B.O.M.)			
ITEM	PART NUMBER	DESCRIPTION	QTY
1	0901128	REMOTE CABLE ASSY 100' AQM 7IN	1
2	11012072	BRACKET,FRONT COVER,HMI,AQM	1
3	90012014	CONVERTER,12V TO 24V,HMI	1
4	90012015	HMI,DISPLAY,7 IN PROGRAMMED	1
5	90012289	DONGLE,HMI,RS485,POWER,AQ	1
6	061060020000	NUT,HEX 6-32 W-INSERT SS	2
7	061080018000	WASHER FLAT #6 SS	2
8	061080028000	WASHER FLAT #10 SS	4
9	061160620008	SC PHIL PAN 6-32 X .50 SS	2
10	061160620020	SC PHIL PAN 6-32 X 1 1/4 SS	4
11	061170628016	SC PHIL PAN A #10 X 1 SS	4

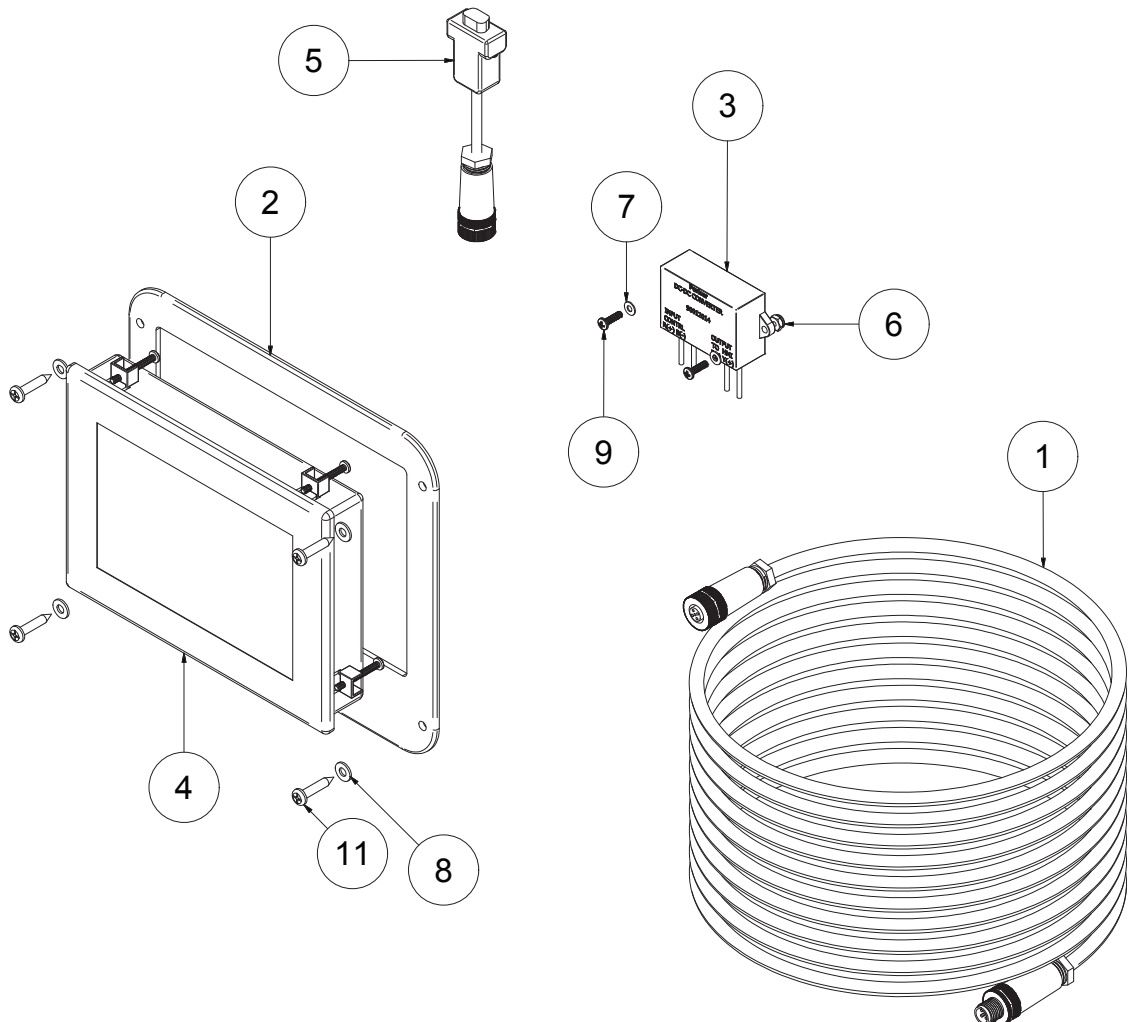

61012030 REMOTE KIT, 200FT CABLE, PARKER

BILL OF MATERIAL (B.O.M.)			
ITEM	PART NUMBER	DESCRIPTION	QTY
1	0901130	REMOTE CABLE ASSY 200' AQM 7IN	1
2	11012072	BRACKET,FRONT COVER,HMI,AQM	1
3	90012014	CONVERTER,12V TO 24V,HMI	1
4	90012015	HMI,DISPLAY,7 IN PROGRAMMED	1
5	90012289	DONGLE,HMI,RS485,POWER,AQ	1
6	061060020000	NUT,HEX 6-32 W-INSERT SS	2
7	061080018000	WASHER FLAT #6 SS	2
8	061080028000	WASHER FLAT #10 SS	4
9	061160620008	SC PHIL PAN 6-32 X .50 SS	2
10	061160620020	SC PHIL PAN 6-32 X 1 1/4 SS	4
11	061170628016	SC PHIL PAN A #10 X 1 SS	4

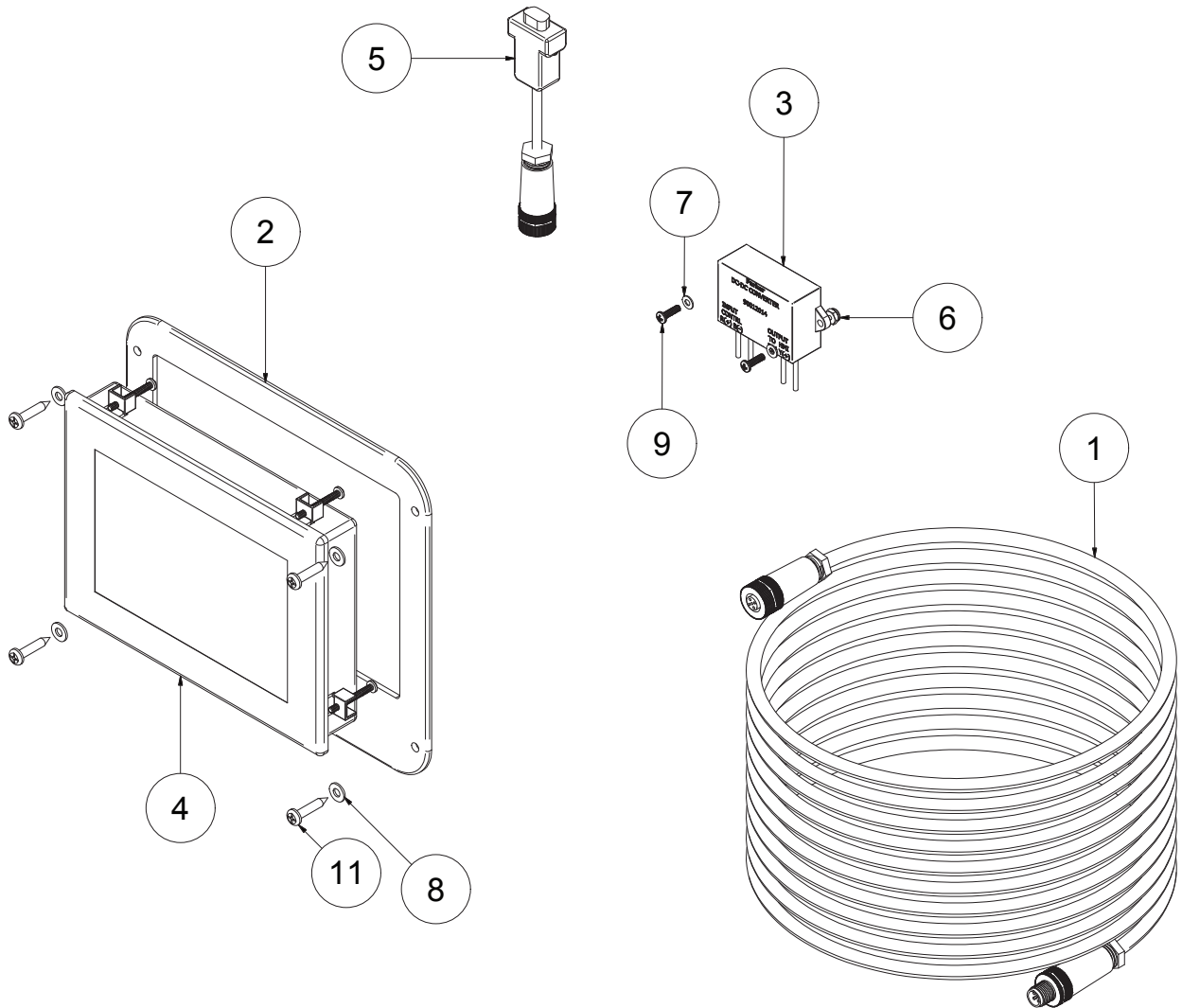

61012032 REMOTE KIT, 200FT CABLE, PARKER 4 INCH HMI

BILL OF MATERIAL (B.O.M.)			
ITEM	PART NUMBER	DESCRIPTION	QTY
1	0901130	REMOTE CABLE ASSY 200' AQM 7IN	1
2	11012164	BEZEL4INCH NEW REMOTE HMI	1
3	90012014	CONVERTER,12V TO 24V,HMI	1
4	90012016	HMI,DISPLAY,4.3" PROGRAMMED	1
5	90012289	DONGLE,HMI,RS485,POWER,AQ	1
6	061060020000	NUT,HEX 6-32 W-INSERT SS	2
7	061080018000	WASHER FLAT #6 SS	2
8	061080028000	WASHER FLAT #10 SS	4
9	061160620008	SC PHIL PAN 6-32 X .50 SS	2
10	061160620020	SC PHIL PAN 6-32 X 1 1/4 SS	4
11	061170628016	SC PHIL PAN A #10 X 1 SS	4

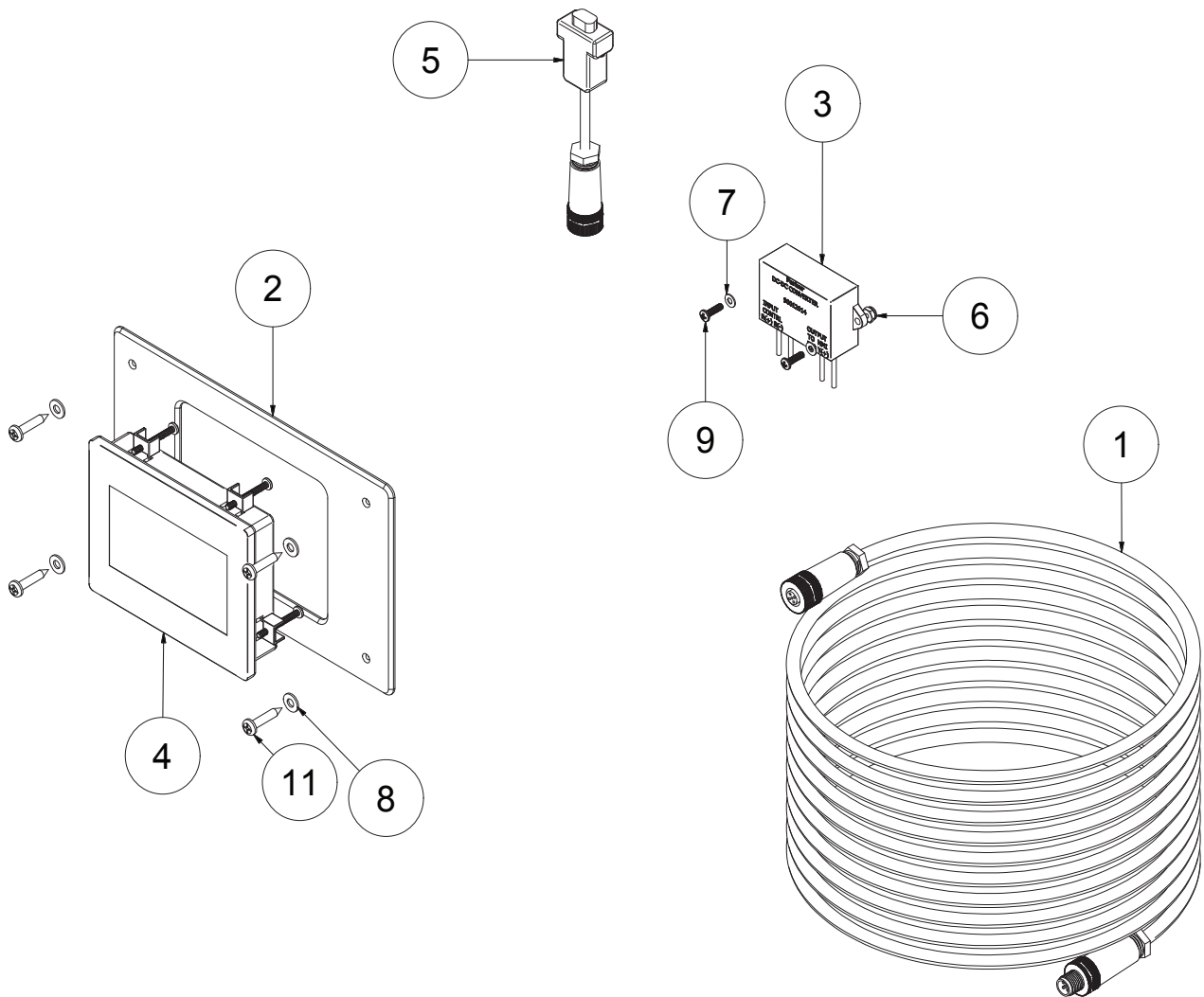

SOFT START ASSY

B596800015 SOFT START 115V 50-60HZ

B596800014 SOFT START 230V 50-60HZ

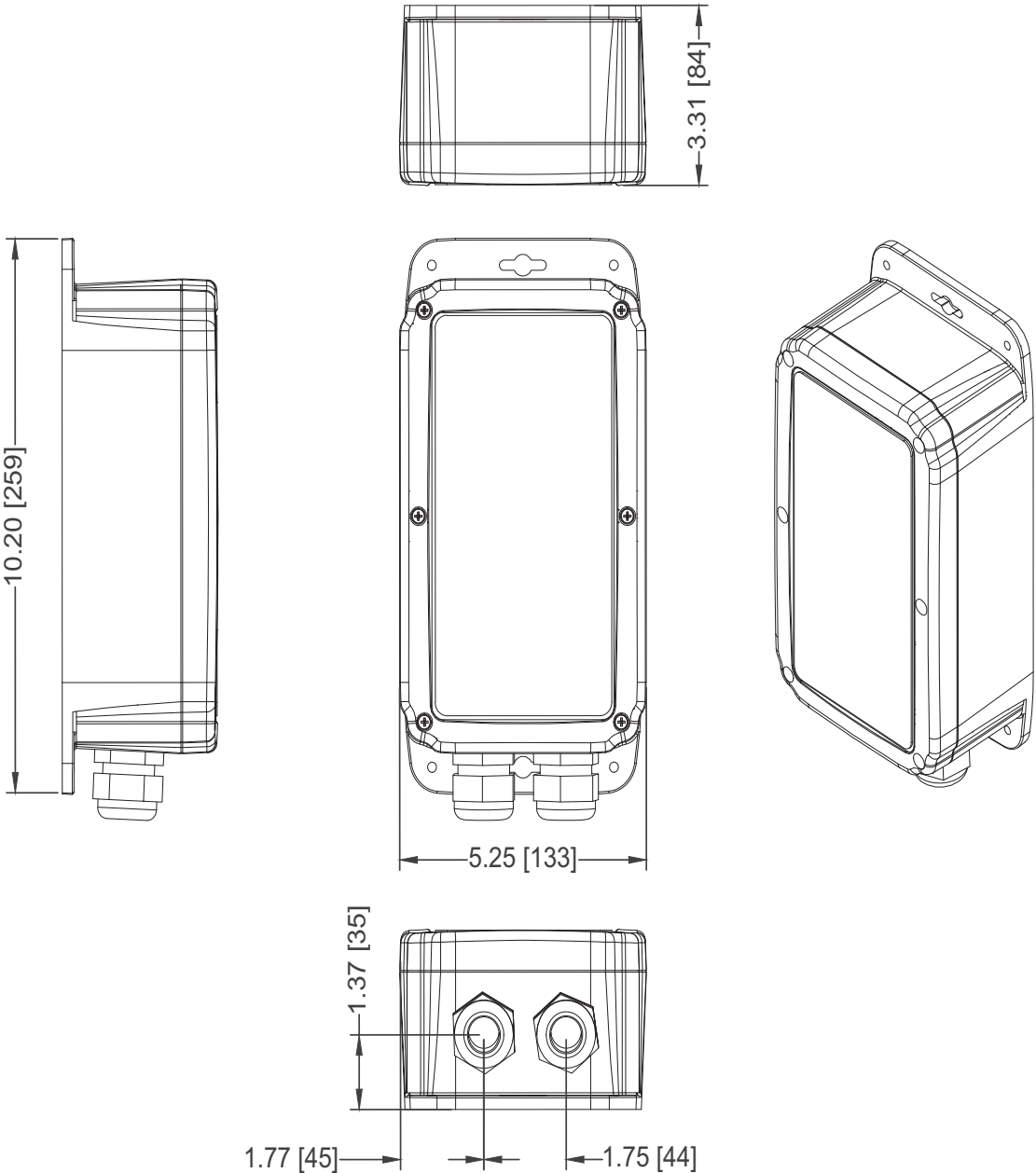

B619160001 CONTROLLER CHASSIS AQMC II 1PH

ITEM NO.	QTY.	PART NO.	DESCRIPTION
1	1	31310603BF	CONTACTOR 30A AW>12/99 12VDC
2	1	31314301CW	POWER SUPPLY 12V DC
3	1	31310110BF	CONTACTOR 9A AUX AW>12/99 12VD
4	2	3131310400	FUSE HOLDER
5	2	3131301500	FUSE QUICK BLOW 2A
6	11	31311523DM	TERMINAL BLOCK
7	1	31318301DK	EMI FILTER
8	2	31311524DM	TERMINAL 8 AWG DIN GREEN

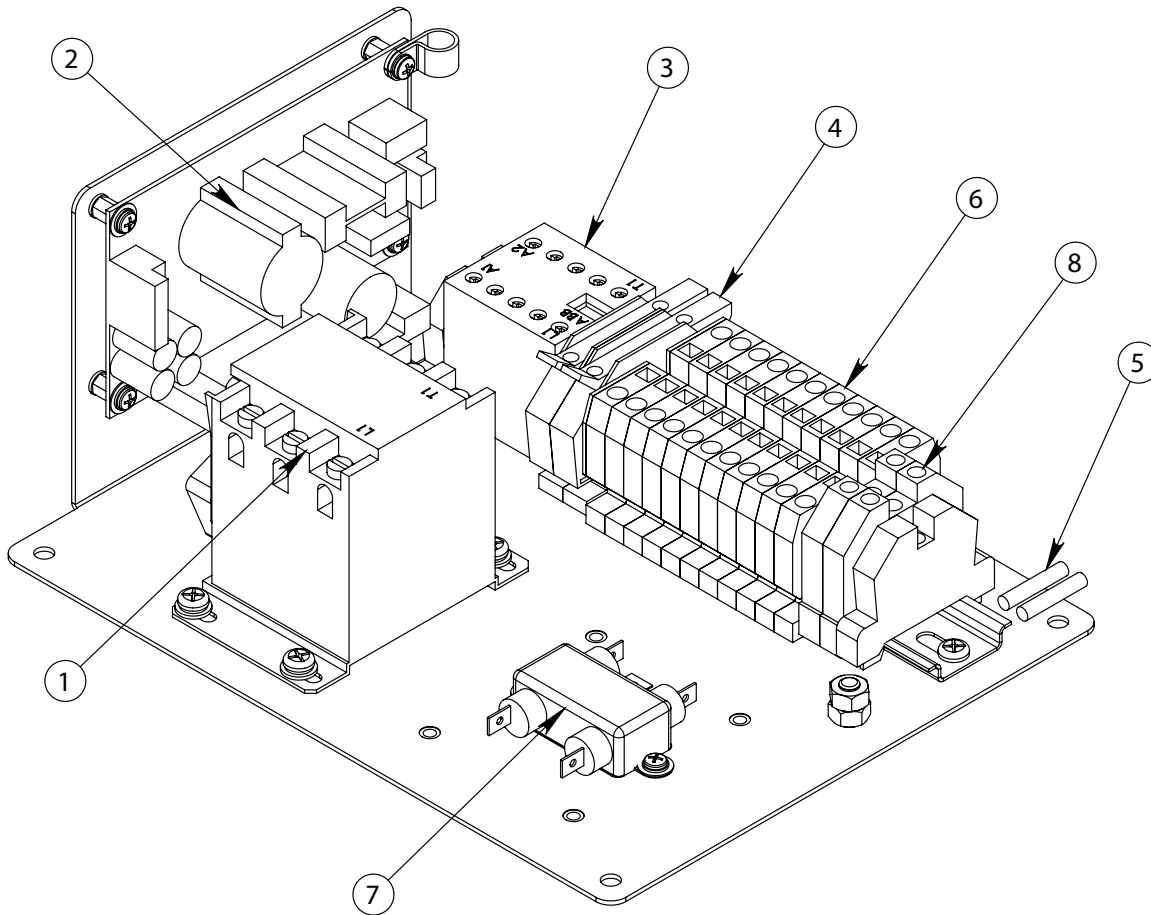

B619160002 CONTROLLER CHASSIS AQMC II 3PH

ITEM NO.	QTY.	PART NO.	DESCRIPTION
1	1	31310603BF	CONTACTOR 30A AW>12/99 12VDC
2	1	3131131500	ELEC TRANSFORMER 480/120 BUCK
3	1	31314301CW	POWER SUPPLY 12V DC
4	1	31310110BF	CONTACTOR 9A AUX AW>12/99 12VDC
5	2	3131310400	FUSE HOLDER
6	11	31311523DM	TERMINAL BLOCK
7	2	31311524DM	TERMINAL 8 AWG DIN GREEN
8	2	3131301500	FUSE QUICK BLOW 2A

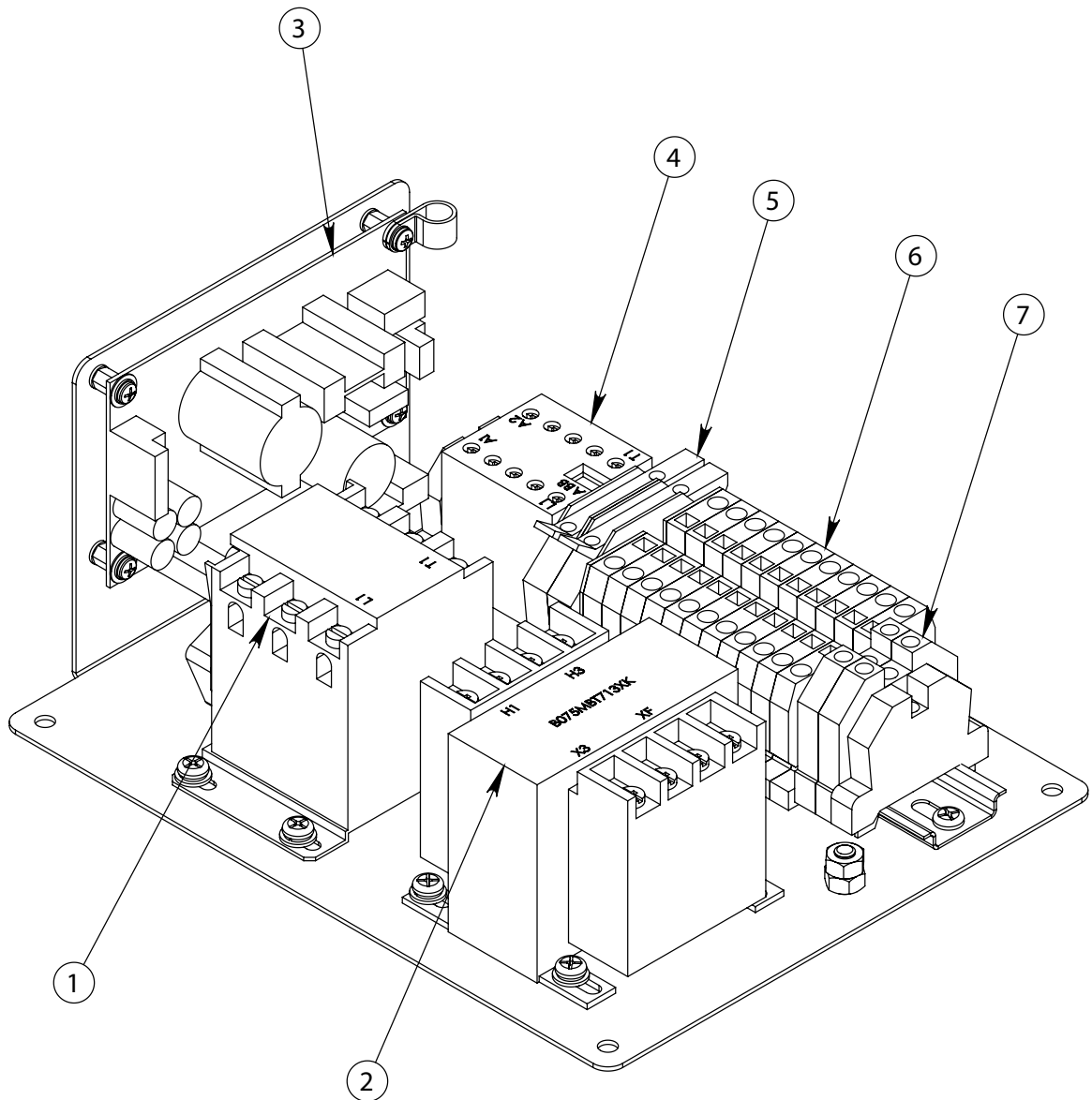

Chapter 12

Electrical Diagrams - Foldouts

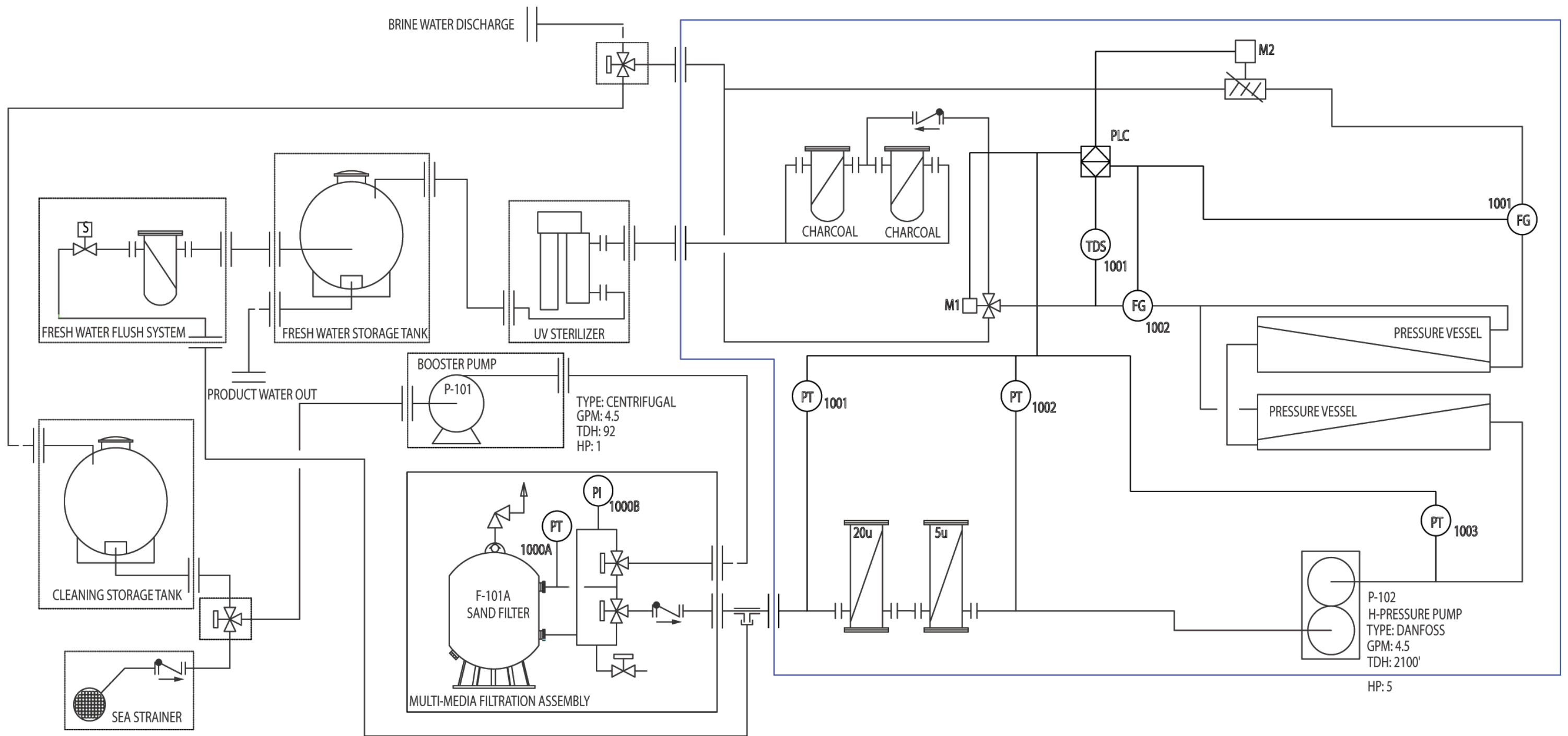

PT-Pressure Transducer
 PI-Pressure Indicator
 M-Meter
 FG-Flow Gauge
 TDS-TDS Meter
 P-Pump
 PLC-Program Logic Controller

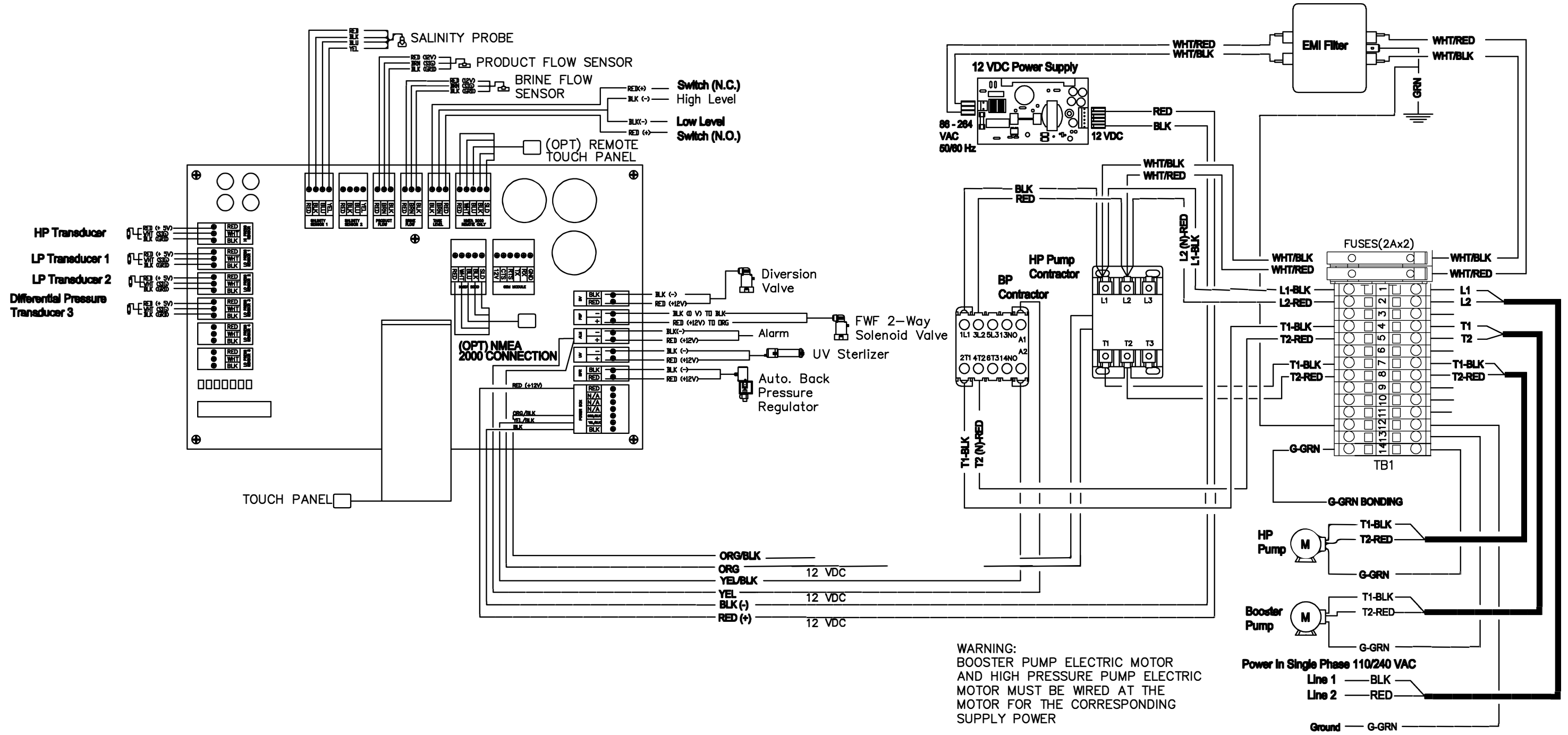

WARNING:
 BOOSTER PUMP ELECTRIC MOTOR
 AND HIGH PRESSURE PUMP ELECTRIC
 MOTOR MUST BE WIRED AT THE
 MOTOR FOR THE CORRESPONDING
 SUPPLY POWER

NOTES:
 1. WIRING DIAGRAM REFERENCES CHASSIS CONTROLLER P/N B619160001 & B619940001.

PROPRIETARY AND CONFIDENTIAL
 THE INFORMATION CONTAINED IN THIS
 DRAWING IS THE SOLE PROPERTY OF
 SEA RECOVERY CORPORATION. ANY
 REPRODUCTION IN PART OR AS A WHOLE
 WITHOUT THE WRITTEN PERMISSION OF
 SEA RECOVERY CORPORATION IS

UNLESS OTHERWISE SPECIFIED		NAME	DATE
DRAWN:	SH	SH	11/20/11
CHECKED:			
ENG APPR:			
MFG APPR:			
QA:			
COMMENTS:			
NEXT ASSY:	USED ON:	FINISH:	TBA

TOLERANCES: FRACTIONAL ±.125 ANGULAR MACH ±.5° TWO PLACE DECIMAL ±.01 THREE PLACE DECIMAL ±.003		TITLE: WIRING DIAGRAM ADM/AQW DX COMPACT / MODULAR 110-240 VAC, 50/60HZ, 1 PHASE	
SIZE:	DWG. NO.:	REV.:	
	941111601C	C	

REVISIONS				
ZONE	REV.	DESCRIPTION	DATE	APPROVED
	C	ADDED TITLE BLOCK	11-30-11	SH
	D	REVISED WIRING DIAGRAM	12-15-11	SH

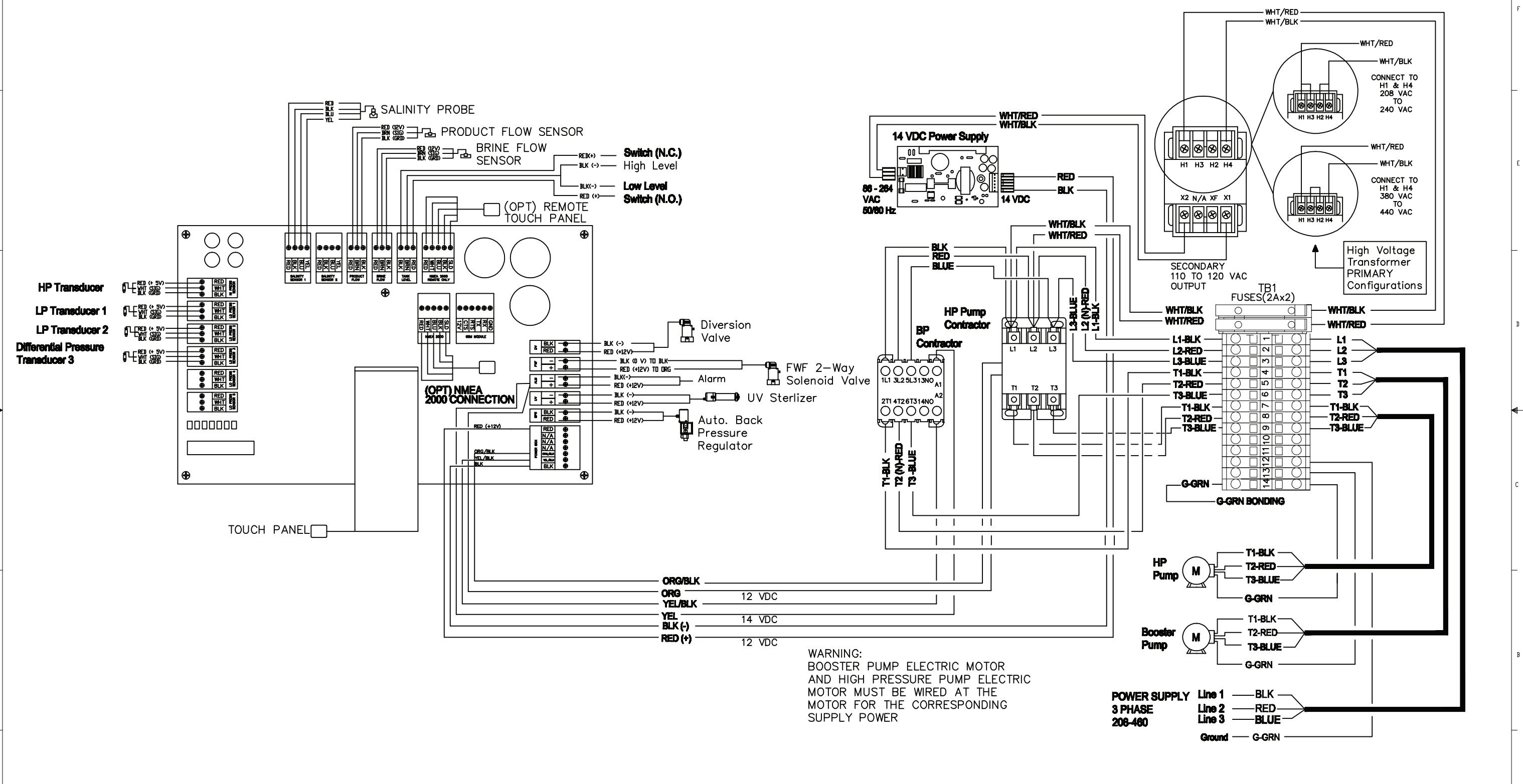

WARNING:
 BOOSTER PUMP ELECTRIC MOTOR
 AND HIGH PRESSURE PUMP ELECTRIC
 MOTOR MUST BE WIRED AT THE
 SUPPLY POWER

NOTES:
 1. WIRING DIAGRAM REFERENCES CHASSIS CONTROLLER P/N B619160002 & B619940002.

PROPRIETARY AND CONFIDENTIAL.
 THE INFORMATION CONTAINED IN THIS
 DRAWING IS THE SOLE PROPERTY OF
 SEA RECOVERY CORPORATION. ANY
 REPRODUCTION IN PART OR AS A WHOLE
 WITHOUT THE WRITTEN PERMISSION OF
 SEA RECOVERY CORPORATION IS
 PROHIBITED.

UNLESS OTHERWISE SPECIFIED		NAME	DATE
DIMENSIONS ARE IN INCHES	DRAWN	SH	11/30/11
TOLERANCES	CHECKED		
FRACTIONAL ±1/16	ENG APPR.		
ANGULAR MACH ±.5°	MFG APPR.		
TWO PLACE DECIMAL ±.01	QA		
THREE PLACE DECIMAL ±.003	COMMENTS		
INTERPRET GEOMETRIC TOLERANCING PER MATERIAL			
TBA			
FINISH			
TBA			

TITLE:	WIRING DIAGRAM AQM/ADW DX COMPACT / MODULAR		
SIZE DWG. NO.	200-460VAC, 50/60HZ, 3 PHASE		
D	941111602D	REV	D
SCALE: 14	WEIGHT:	SHEET 1 OF 1	

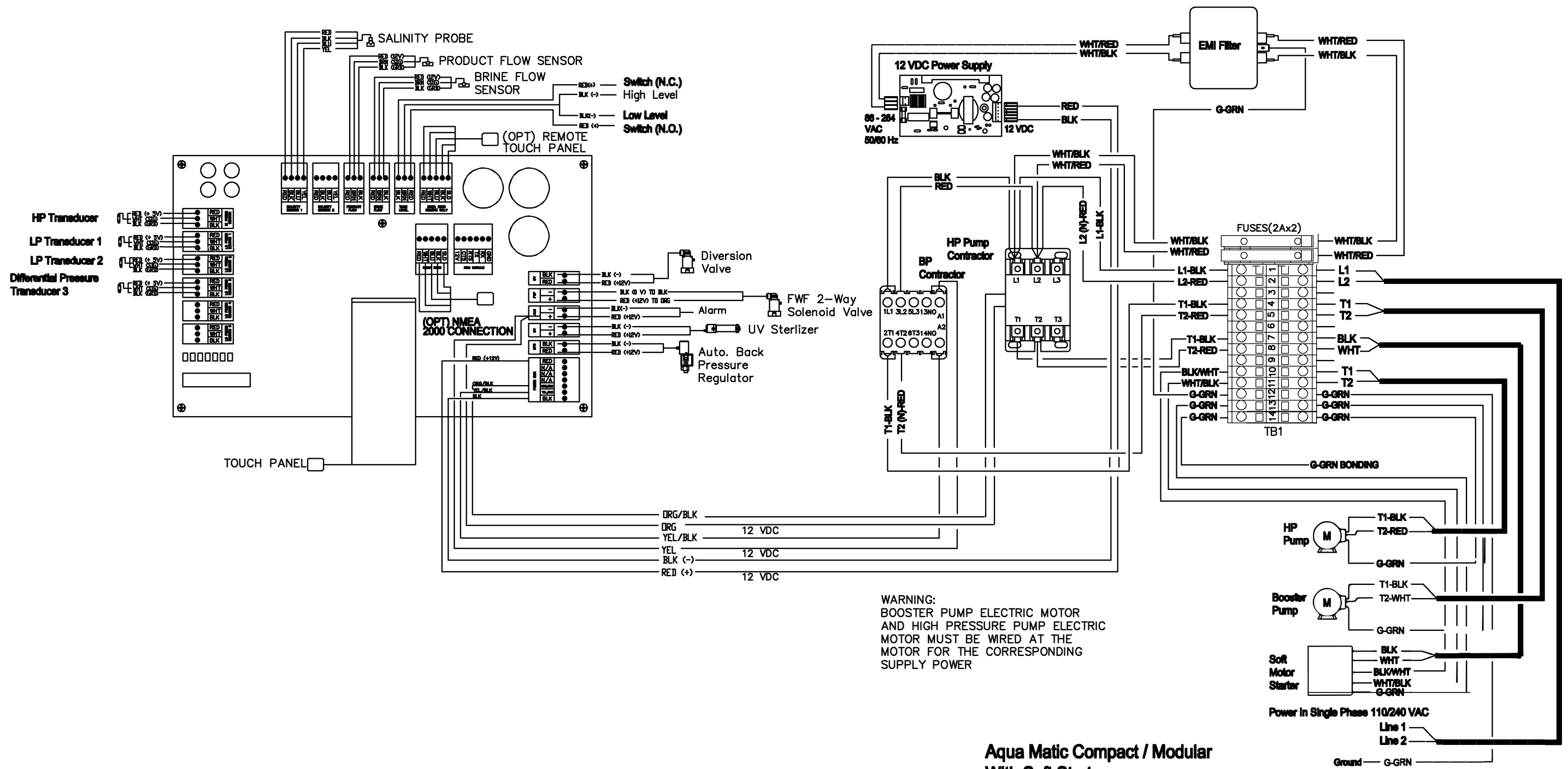

NOTES:
 1. WIRING DIAGRAM REFERENCES CHASSIS CONTROLLER P/N B619160001 & B619940001.

UNLESS OTHERWISE SPECIFIED		NAME	DATE
DIMENSIONS ARE IN INCHES	BROWN	SH	11/30/11
TOLERANCES	CHECKED		
FUNCTIONAL 1/16	ENG APPR		
ANGULAR MATCH ±.5°	INFO APPR		
TWO PLACE DECIMAL			
THREE PLACE DECIMAL ± .003			
INTERPRET GEOMETRIC TOLERANCING PER:	QA		
MATERIAL:	COMMENTS:		
TBA			
FINISH:			
TBA			
NEXT ASSY:	USED ON:		

TITLE: WIRING DIAGRAM AQM/AQW DX COMPACT / MODULAR, W/ SOFT START 110-240 VAC, 50/60 HZ, 1 PHASE	
SIZE: DWG: NCI 941111603C	REV: C

**ELECTRICAL
UPDATE AS OF 10/30/2017**

REVISIONS				
ZONE	REV.	DESCRIPTION	DATE	APPROVED
			11-30-11	SH
D		ADDED NEW CONTROLLER TO DESIGN	12-16-16	AGE

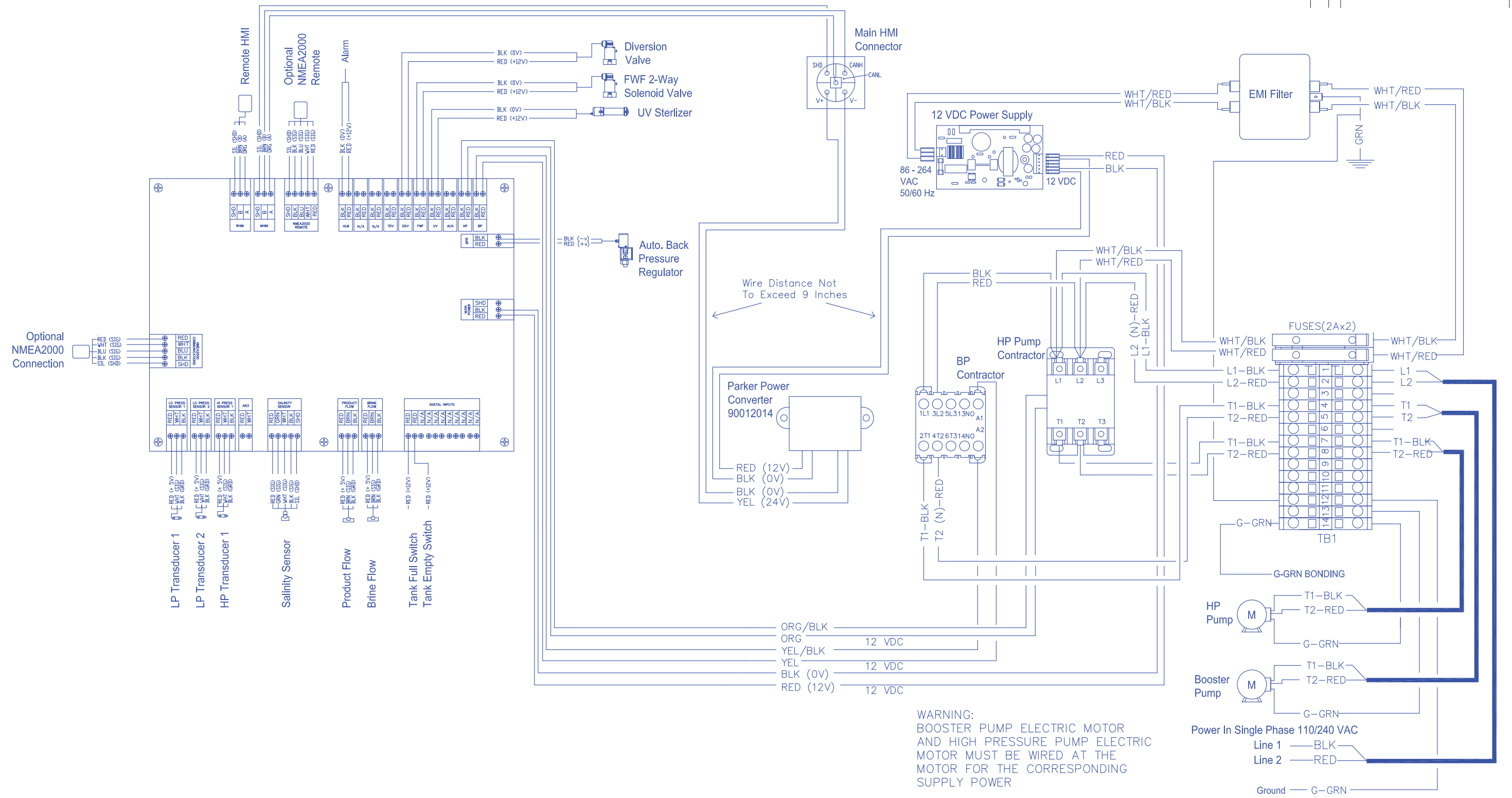

NOTES:
 1. WIRING DIAGRAM REFERENCES CHASSIS CONTROLLER P/N B619160001 & B619940001.

PROPRIETARY AND CONFIDENTIAL
 THE INFORMATION CONTAINED IN THIS DRAWING IS THE SOLE PROPERTY OF SEA RECOVERY CORPORATION. ANY REPRODUCTION IN PART OR AS A WHOLE WITHOUT THE WRITTEN PERMISSION OF SEA RECOVERY CORPORATION IS PROHIBITED.

UNLESS OTHERWISE SPECIFIED		NAME	DATE
DIMENSIONS ARE IN INCHES	TOLERANCES	DRAWN	SH
FRACTIONAL ±1/16	DECIMAL ±0.005	CHECKED	11/30/11
ANGULAR ±0.5°	TWO PLACE DECIMAL ±0.01	ENG APPR.	
THREE PLACE DECIMAL ±0.003		MFG APPR.	
INTERPRET GEOMETRIC TOLERANCING PER:		QA	
WATERGAL		COMMENTS:	
TBA			
TBA			
NEXT ASSY	USED ON	FINISH	
		TBA	
APPLICATION			

TITLE:		Sea Recovery Corp.	
WIRING DIAGRAM AQM/AQW DX		11/30/11	
COMPACT / MODULAR			
110-240 VAC, 50/60HZ, 1 PHASE			
SIZE DWG. NO.	REV		
D 941111601C	D		
SCALE: 1:4	WEIGHT:		
		SHEET 1 OF 1	

AQUAMATIC/AQUQWHIPSER DX MODULAR WIRING DIAGRAM

200-460VAC, 50/60HZ, 3 Phase Controller

REVISIONS				
ZONE	REV.	DESCRIPTION	DATE	APPROVED
E		REMOVED JUMPERS FROM TRANSFORMER. JUMPERS NO LONGER REQUIRED.	08-29-13	GD
F		REVISED WIRING DIAGRAM ADDED 220-240V CONNECTIONS	12-17-13	PK
G		REVISED WIRING DIAGRAM FOR NEW CONTROLLER	12-01-13	AGE

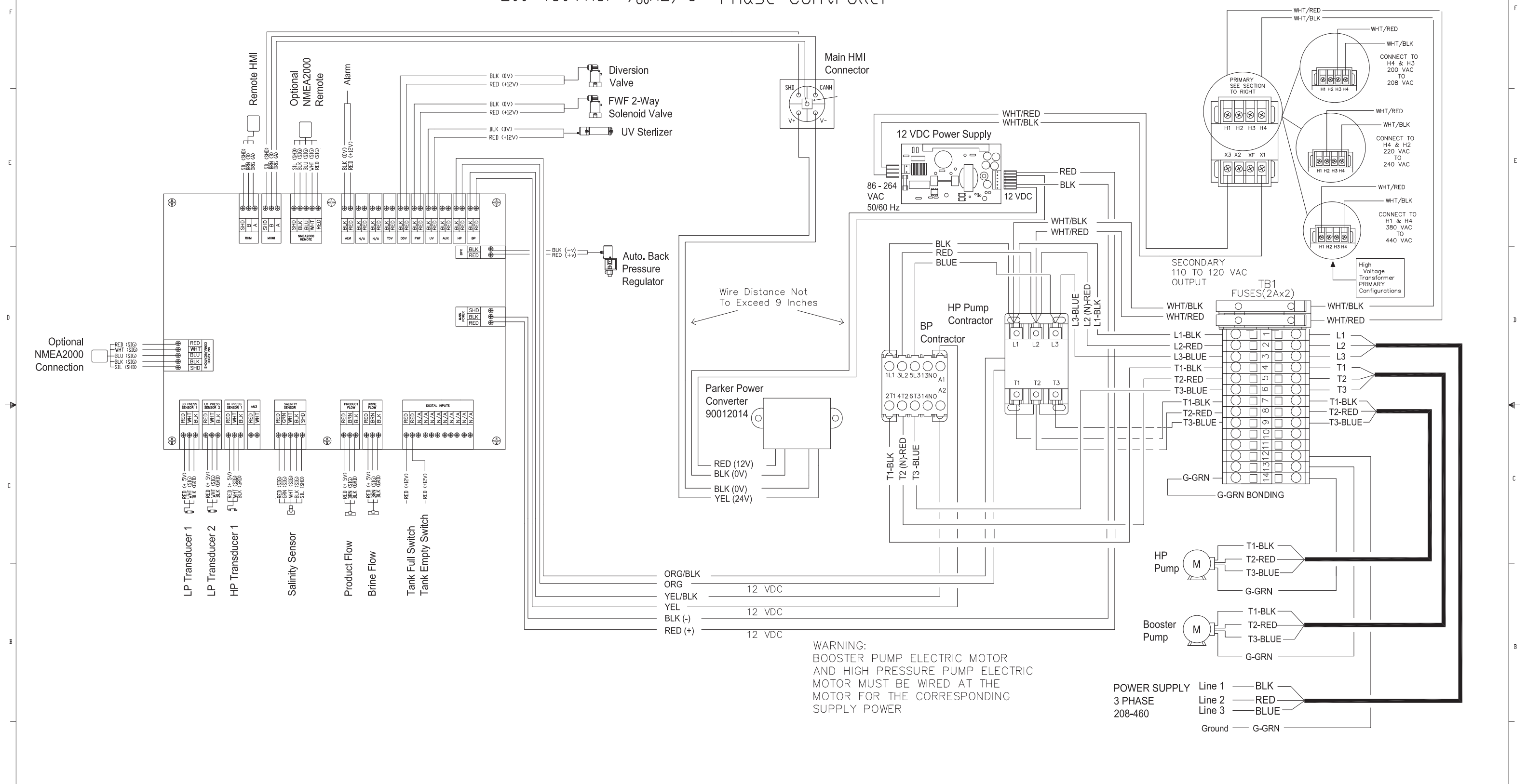

Optional NMEA2000 Connection

POWER SUPPLY
3 PHASE
208-460
Line 1 — BLK
Line 2 — RED
Line 3 — BLUE
Ground — G-GRN

NOTES:
1. WIRING DIAGRAM REFERENCES CHASSIS CONTROLLER P/N B619160002 & B619940002.

PROPRIETARY AND CONFIDENTIAL
THE INFORMATION CONTAINED IN THIS
DRAWING IS THE SOLE PROPERTY OF
SEA RECOVERY CORPORATION. ANY
REPRODUCTION IN PART OR AS A WHOLE
WITHOUT THE WRITTEN PERMISSION OF
SEA RECOVERY CORPORATION IS
PROHIBITED.

UNLESS OTHERWISE SPECIFIED		NAME	DATE
DIMENSIONS ARE IN INCHES	TOLERANCES	DRAWN	SH
FRACTIONAL: 1/16	ANGULAR: MACH ± 5°	CHECKED	
TWO PLACE DECIMAL: ± .01	THREE PLACE DECIMAL: ± .003	ENG APPR	
INTERPRET GEOMETRIC TOLERANCING PER:		DATE	
MATERIAL	TBA	COMMENTS:	
FINISH	TBA		
APPLICATION			

Sea Recovery Corp.
10000 South Shore Blvd.
San Diego, CA 92121
Tel: 619-444-1111

TITLE:
WIRING DIAGRAM AQM/AQW DX
COMPACT / MODULAR
200-460VAC, 50/60HZ, 3 PHASE

SIZE DWG. NO.
D B619940002

REV
G

SCALE: 1:4 WEIGHT: SHEET 1 OF 1



Part Number: B651140001



Sea Recovery Corporation
P.O. Box 5288 • Carson, CA 90745-5288 • sales@searecovery.com

www.searecovery.com