

BGT Series

Tanktop Mounted Return Line Filters

Max. 2400 l/min - 10 bar



Patented *LEIF*[®] elements safeguard filtration quality

When high flow performance is needed

The BGT Series features pre-filtration by means of a magnet column and a full flow bypass with low hysteresis. Maximum pressure 10 bar. Maximum flow 2400 l/min. *LEIF*[®] elements available up to 1500 l/min. Designed for a wide range of mobile and industrial applications



Contact Information:

Parker Hannifin
Hydraulic Filter Division Europe

European Product
Information Centre
Freephone: 00800 27 27 5374
(from AT, BE, CH, CZ, DE, EE, ES,
FI, FR, IE, IT, PT, SE, SK, UK)
filtrationinfo@parker.com

www.parker.com/hfde

Product Features:

- BGT features pre-filtration by means of a magnet column.
- Filter heads with multiple ports available.
- Flow from inside to out.
- Full flow bypass with low hysteresis.
- Maximum pressure 10 bar. Maximum flow 2400 l/min.
- Patented *LEIF*[®] elements safeguard filtration quality.

BGT Series

Tanktop Mounted Return Line Filters

Features & Benefits

Features	Advantages	Benefits
10 bar rated filter	Can be utilised for severe return line applications	Reduced downtime due to premature filter failures
Cast aluminium head	Compact profile, lightweight and durable	Less weight, smaller envelop and cleaner appearance
LEIF® elements	Element safeguards the use of genuine parts	Guaranteed quality of filtration Contributes to ISO 14001 certification
Magnetic pre-filtration	Removes ferrous particles, even during bypass conditions	Improved fluid cleanliness levels Extended element life time
In-to-Out filtration	All captured contamination retains inside the element	No recontamination of system during change of elements
High level of customisation	Dedicated system-matched solutions can be easily made available	Improved integration of filter in system combined with lower initial system costs
Quick response bypass with low hysteresis	Reduction of bypass period due to low hysteresis Only a small part of the total flow is bypassing the element	Improved protection of system
Standard or customised funnel	Ensures that oil enters the tank under the oil level	Significant reduction of oil foaming

Typical Applications

- Mobile cranes
- Excavators
- Deck cranes
- Fire fighting equipment
- Hydraulic presses
- Waste balers
- Industrial power units
- Fork lift trucks

The Parker Filtration BGT Series Tank Mounted Return Line Filters.

BGT tanktop mounted return line filters feature pre-filtration by means of a magnet column and a quick response bypass with low hysteresis. Thanks to the 'In-to-Out' filter principle, contaminated oil cannot leak back into the system. BGT Filters are available in versions capable of handling flow rates up to 2400 l/min. They can operate with a maximum working pressure of 10 bar. LEIF® elements are available for environment-friendly filtration for versions up to 1500 l/min.



Specification

Operating pressure:

Max. 10 bar.

Assembly:

Tank top mounted.

Connections:

Flanges SAE2", 3".

Threaded ports and multiple ports available.

Filter housing:

Aluminium head and cover.

Seal material:

Nitrile, fluoroelastomer, neoprene.

Operating temperature range:

Seal material Nitrile: -40° to +100°C.

Seal material Fluoroelastomer: -20° to +120°C.

Bypass setting

Opening pressure 0.8 / 1.5 or 2 bar.

Other settings on request.

Degree of filtration:

Determined by multipass test according to ISO 16889.

Flow fatigue characteristics:

Filter media is supported so that the optimum fatigue life is achieved.

Filtration media:

Microglass III and Ecoglass III for *LEIF*[®] elements.

Also available 10µm Cellulose and 40µm stainless steel mesh.

Element burst rating:

10 bar (ISO 2941).

Pressure indicator options:

Setting 0.7 or 1.2 bar.

Other settings on request.

Visual pressure gauge.

Electrical pressure switch.

Options:

Diffuser type P (straight pipe, no perforated plate area)

Diffuser type T (with closed diffuser end cap and with perforated plate area, recommended when oil entry in reservoir is close to the reservoir bottom or to ensure oil entry under the reservoir oil level)

Magnetic pack:

Standard.

Filling port in cover (optional):

BGT 3 = Plugged G1¹/₄. BGT 4 = Plugged G1¹/₂.

Filter element:

LEIF[®] element with reusable metal element sleeve.

Conventional style element with steel end caps.

The *LEIF*[®] element is patented and safeguards the use of genuine parts.

Note:

LEIF[®] element can be used with mineral and HEES type oils.

For other fluids consult Parker Filtration.

LEIF[®] contributes to ISO 14001 quality standards.

BGT-3 Length 11 and 12 (<i>LEIF</i> [®] version)		
Ref.	No.	Description
1	1	Nut
2	1	Washer
3	1	Cover
4	1	Cover-seal
5	1	Top-spring
6	1	Housing
7	1	Insert-seal
8	1	Plug M10x1
9	1	Bonded seal
10	1	Insert
11	1	<i>LEIF</i> [®] element
12	1	Element sleeve
13	1	Gasket
14	1	O-ring
15	1	Bypass set
16	1	Diffuser

BGT-4 Length 13 and larger (conventional element)		
Ref.	No.	Description
1	1	Nut
2	1	Washer
3	1	Cover
4	1	Cover-seal
5	1	Top-spring
6	1	Housing
7	1	Insert-seal
8	1	Plug M10x1
9	1	Bonded seal
10	1	Insert
11	1	Element seal
12	1	Element
13	1	O-ring
14	1	O-ring
15	1	Bypass set
16	1	Diffuser

BGT-3 (*LEIF*[®] version)

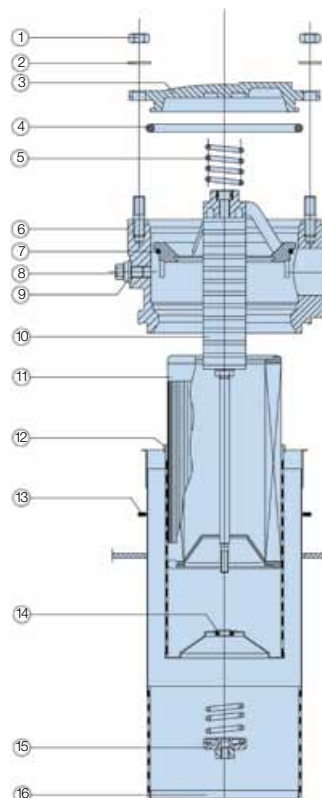

BGT-4 (conventional element)

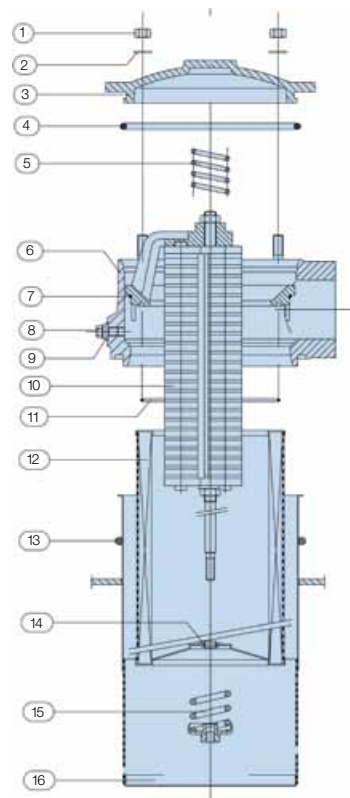

BGT Series

Tanktop Mounted Return Line Filters

Specification (cont.)

BGT-3 with diffuser

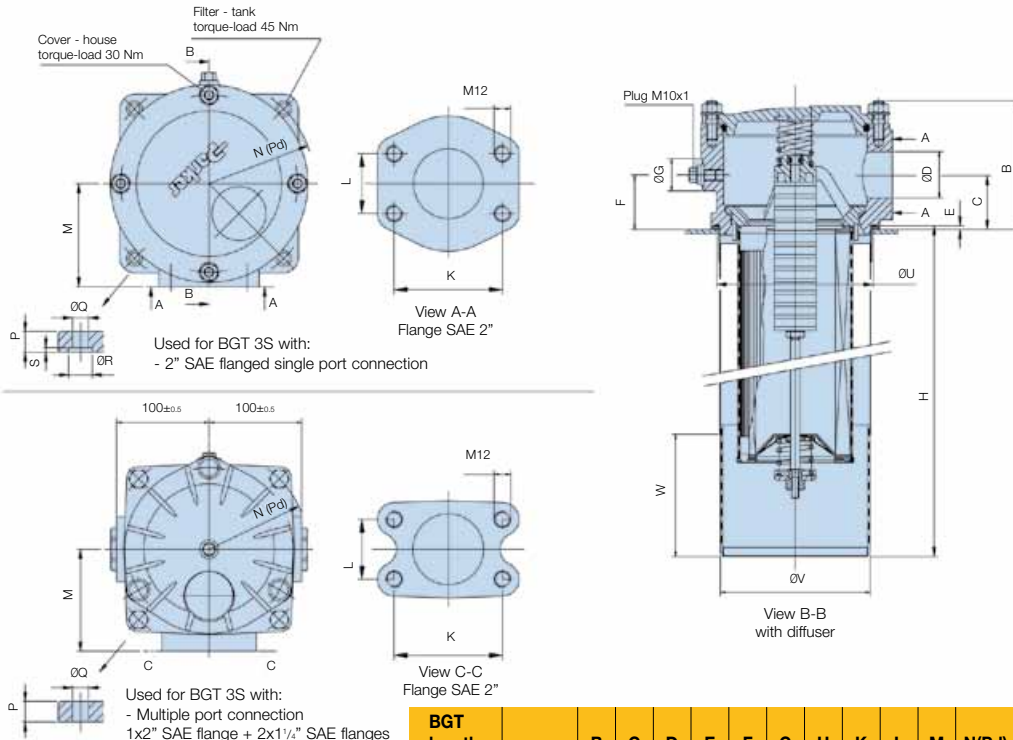

Dimensions in mm

BGT length		B	C	D	E	F	G	H	K	L	M	N(Pd)	P	Q	R	S	U	V	W	Kg.
11	BGT390	139	59	50	3	59	35	350	78	43	105	R107.5	14	13	16	3	165.5 ^{+0.5} ₀	165	120	7.2
12	BGT500							540												8.6
Multiple port connection		(131)	(55)			(55)					(110)		(15)				(166 ^{+0.5} ₀)			

BGT-3 without diffuser

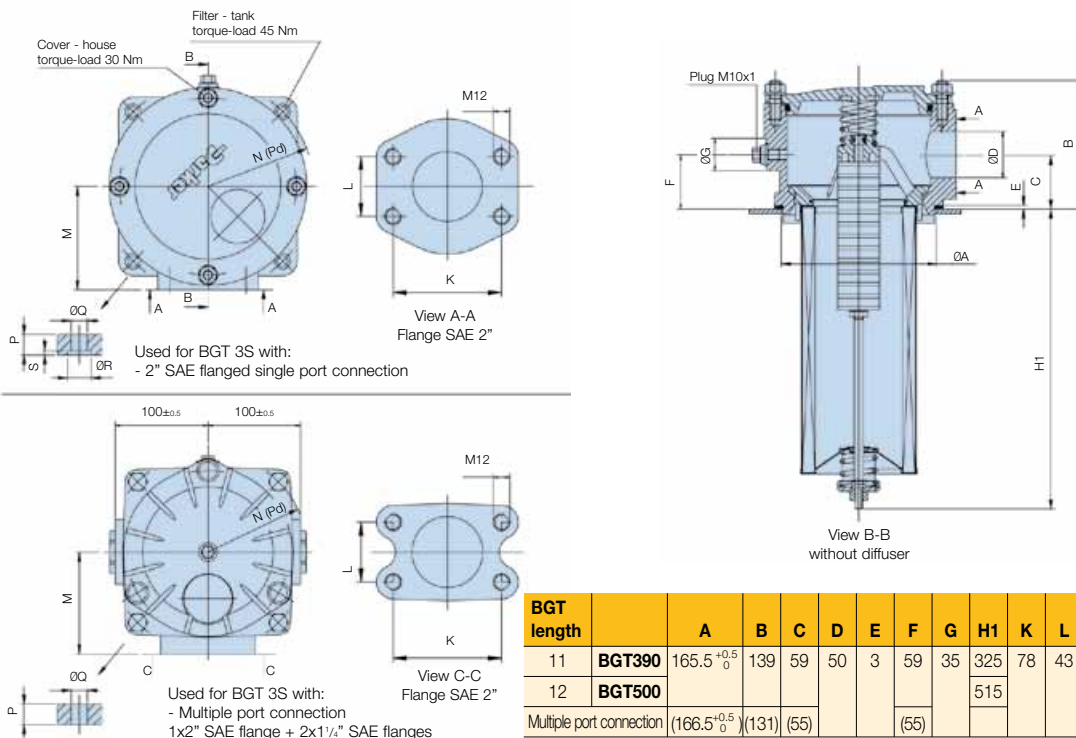

Dimensions in mm

BGT length		A	B	C	D	E	F	G	H1	K	L	M	N(Pd)	P	Q	R	S	Kg.
11	BGT390	165.5 ^{+0.5} ₀	139	59	50	3	59	35	325	78	43	105	R107.5	14	13	16	3	7.2
12	BGT500								515									8.6
Multiple port connection		(166.5 ^{+0.5} ₀)	(131)	(55)			(55)					(110)		(15)				



BGT-4 with diffuser

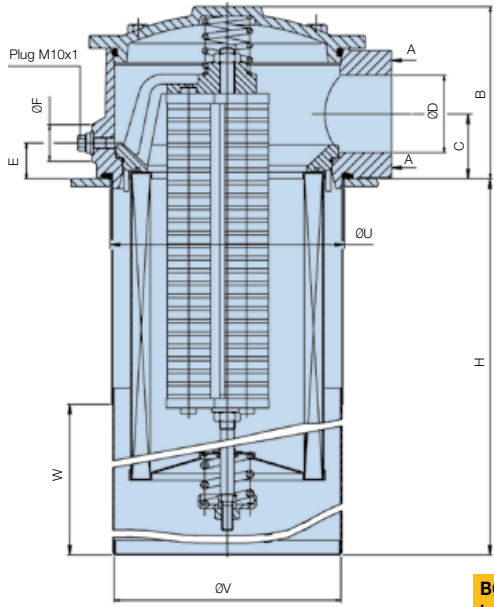

View B-B with diffuser

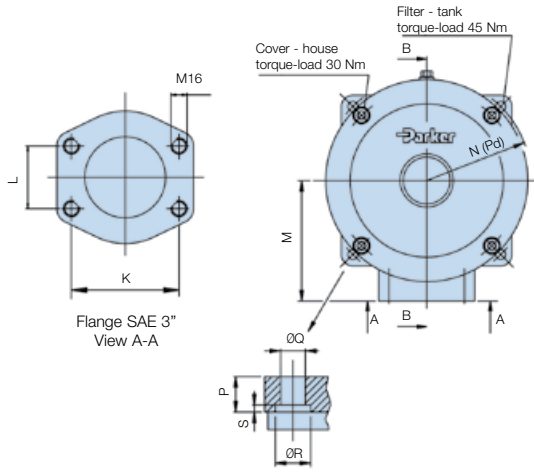

BGT length		B	C	ØD	E	ØF	H	K	L	M	N(Pd)	P	ØQ	ØR	S	ØU	ØV	W	Kg.
13	BGT600						425												20.5
14	BGT800						535												23.0
15	BGT1000	178	67	80	37	40	640	106.4	62	170	R147.5	20	14	20	4	240.5 ^{+0.5} ₀	240	170	25.5
16	BGT1500						920												30.0
17	BGT2000						1200												37.0
18	BGT2400						1200												37.0

Note: dimensions of BGT-2400 identical to BGT-2000. Dimensions in mm

BGT-4 without diffuser

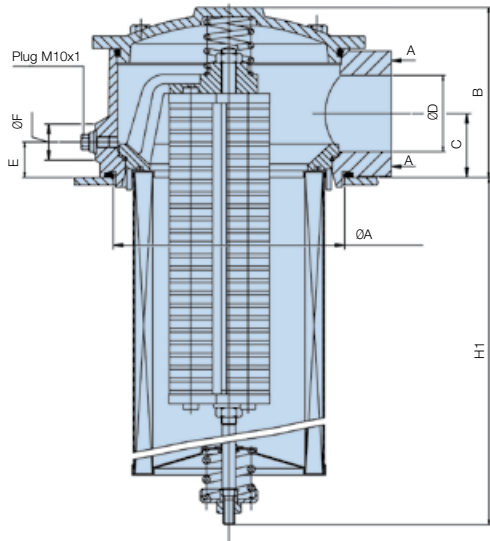

View B-B without diffuser

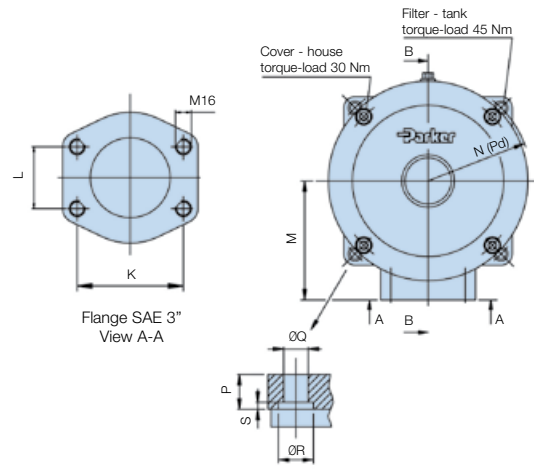

BGT length		ØA	B	C	ØD	E	ØF	H1	K	L	M	N(Pd)	P	ØQ	ØR	S	Kg.
13	BGT600							385									20.5
14	BGT800							495									23.0
15	BGT1000	239.5 ^{+0.5} ₀	178	67	80	37	40	598	106.4	62	170	R147.5	20	14	20	4	25.5
16	BGT1500							878									30.0
17	BGT2000							1143									37.0
18	BGT2400							1143									37.0

Note: dimensions of BGT-2400 identical to BGT-2000. Dimensions in mm



BGT Series

Tanktop Mounted Return Line Filters

Specification (cont.)

BGT F1¼ manifold type - with diffuser

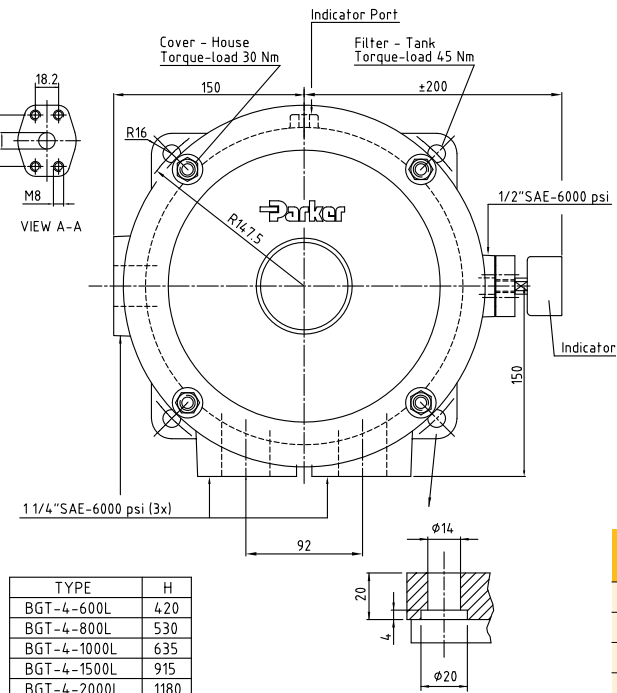
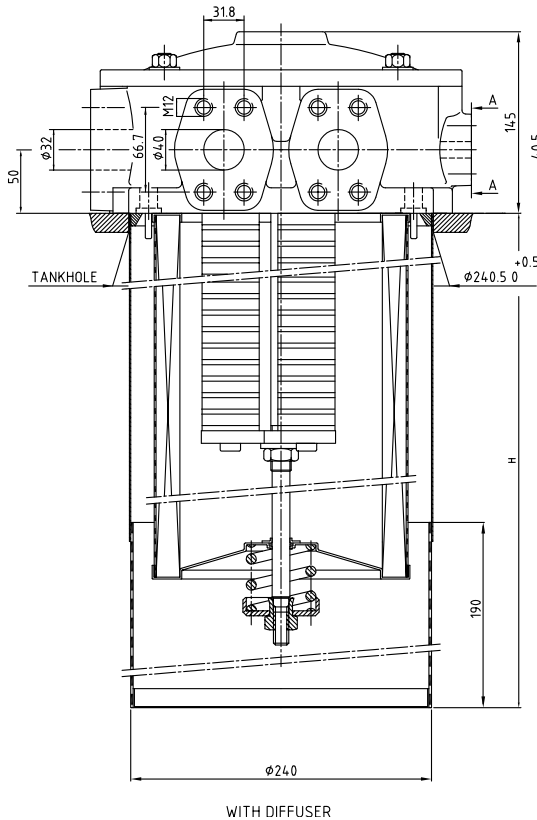

TYPE	H
BGT-4-600L	420
BGT-4-800L	530
BGT-4-1000L	635
BGT-4-1500L	915
BGT-4-2000L	1180

BGT length		H
13	BGT600L	420
14	BGT800L	530
15	BGT1000L	636
16	BGT1500L	915
17	BGT2000L	1180
18	BGT2400L	1180

Dimensions in mm

BGT F1¼ manifold type - without diffuser

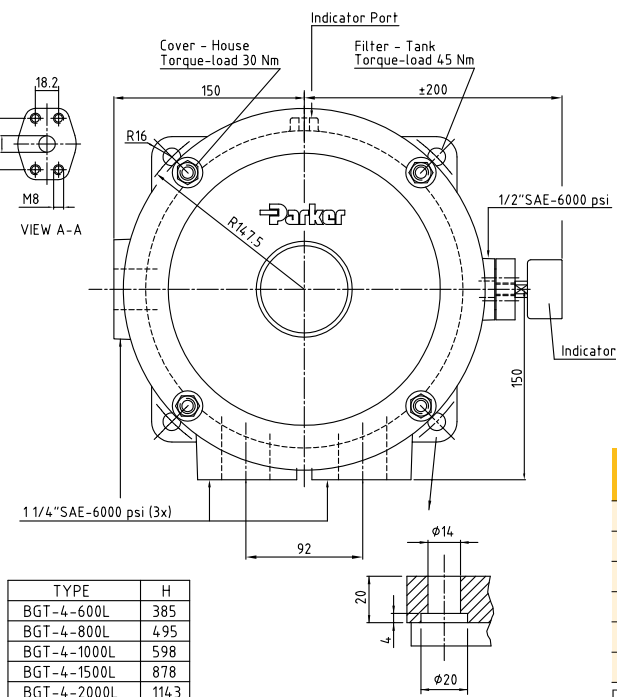
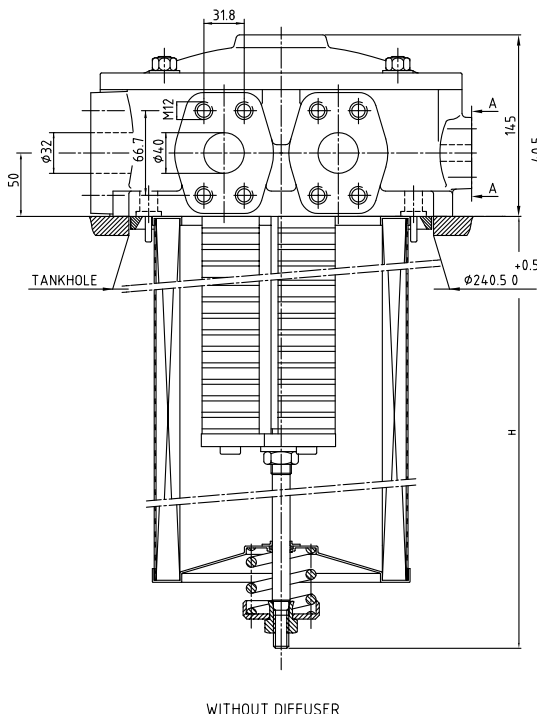

TYPE	H
BGT-4-600L	385
BGT-4-800L	495
BGT-4-1000L	598
BGT-4-1500L	878
BGT-4-2000L	1143

BGT length		H
13	BGT600L	385
14	BGT800L	495
15	BGT1000L	598
16	BGT1500L	878
17	BGT2000L	1143
18	BGT2400L	1143

Dimensions in mm



Indicator Options

Indicator PS pressure switch

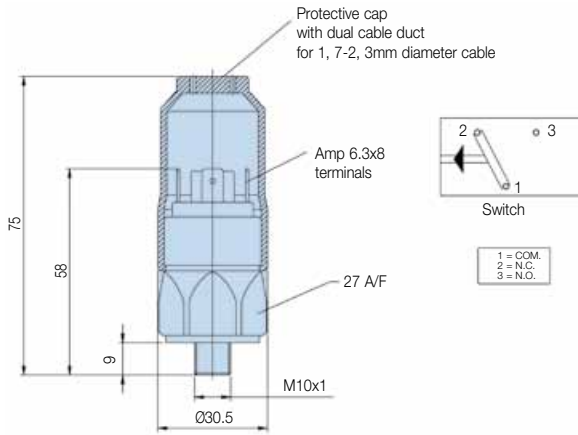

Specifications	
Elec.rating	42V / 4A
Thread connection	M10x1
Elec.connection	AMP 6.3x0.8 terminals + protective cap
Protection	IP65 (with cap) terminals IP00
Code	FMUS1EBMM10L (Switch)

Indicator Connem / Filter Head Matrix	
Port(s) Filter head	Indicator Thread
2" SAE BGT length 11 and 12	M10
3" SAE BGT Length 13 and larger	M10
1x2"SAE Flanged + 2 x 1 1/4" SAE Flanged for BGT Length 11 and 12	G1/8"
3x1 1/4" SAE Flanges + 1x 1/2" SAE for BGT Length 13 and larger	G1/8"

Indicator PS NO/NC pressure switch

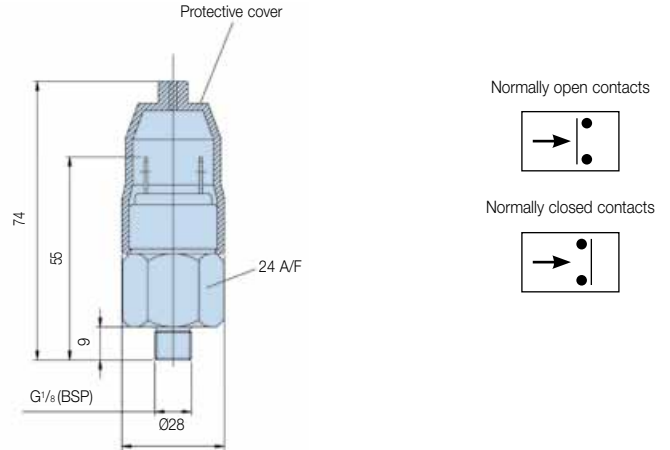

Specifications	
Elec.rating	42V / 2A
Thread connection	G1/8
Elec.connection	AMP terminal 6.3x0.8
Protection	IP65 (terminal IP00)
Switch type	NO or NC
Code	FMUS2EBMG02L (NO switch) FMUS3EBMG02L (NC switch)

Visual indicator	1.2 bar
M10 code	FMUG1EBPM10L
G1/8 code	FMUG2EBPG02L

Pressure Drop Curves

The recommended level of the initial pressure drop for low pressure filters is max 0.5 bar.

If the medium used has a viscosity different from 32cSt, pressure drop over the filter can be estimated as follows:

$$\Delta p = (\Delta p_{32} \times \text{viscosity of medium used}) / 32\text{cSt}$$

Filter housing and element pressure drop based on 32cSt fluid viscosity and 0.87 density.

BGT Empty Housing 2"SAE (Length code 11 and 12)

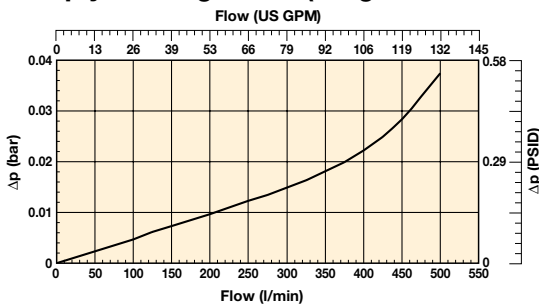

BGT390 (Element length code 11)

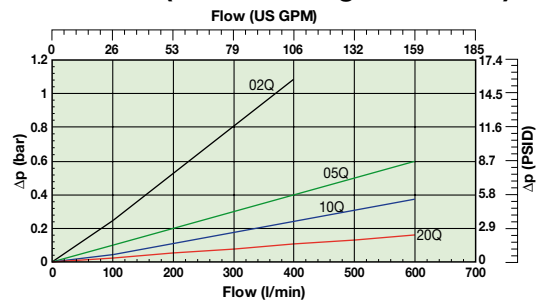

BGT500 (Element length code 12)

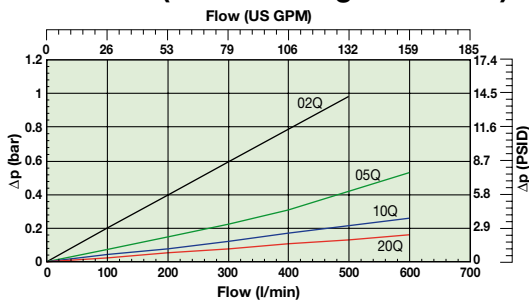

BGT Series

Tanktop Mounted Return Line Filters

Pressure Drop Curves (cont.)

BGT Empty Housing 3"SAE (Length 13 and larger)

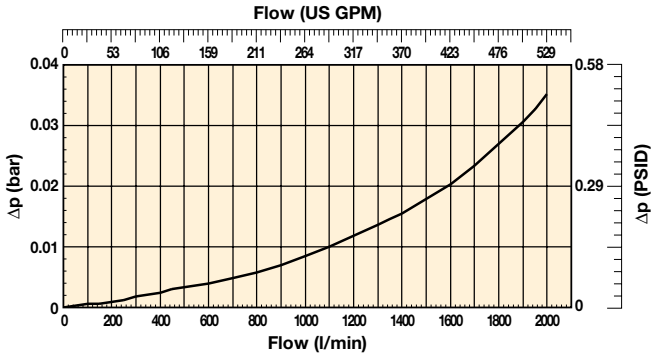

BGT600 (Element length code 13)

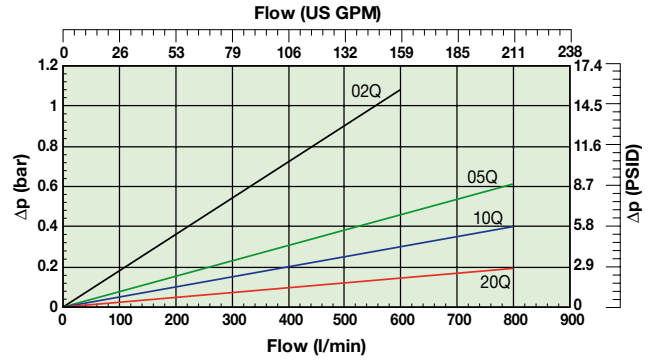

BGT800 (Element length code 14)

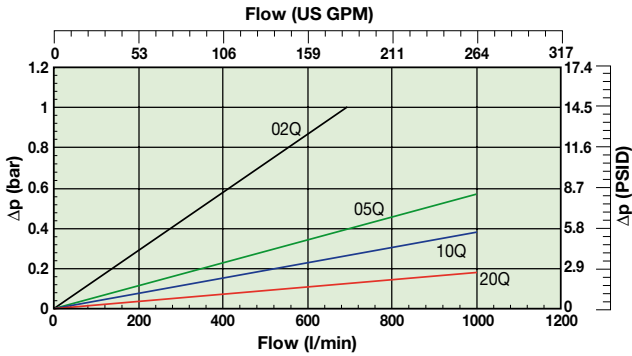

BGT1000 (Element length code 15)

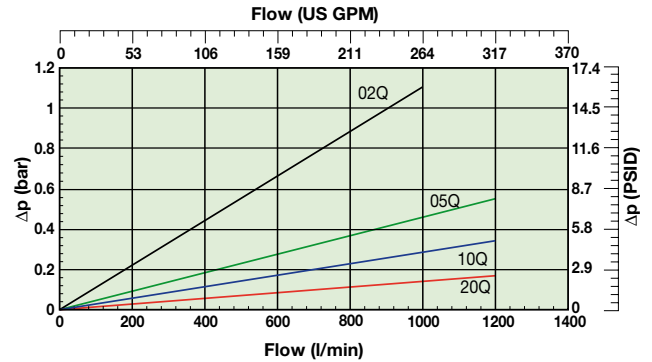

BGT1500 (Element length code 16)

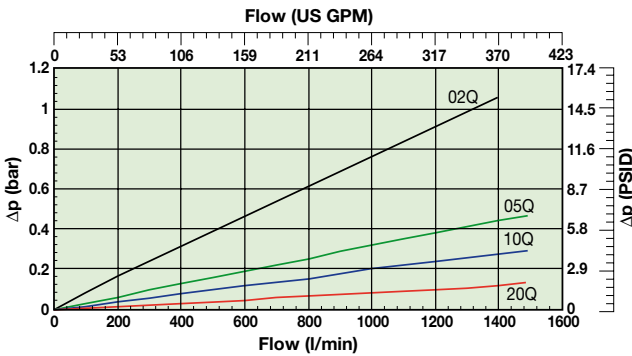

BGT2000 (Element length code 17)

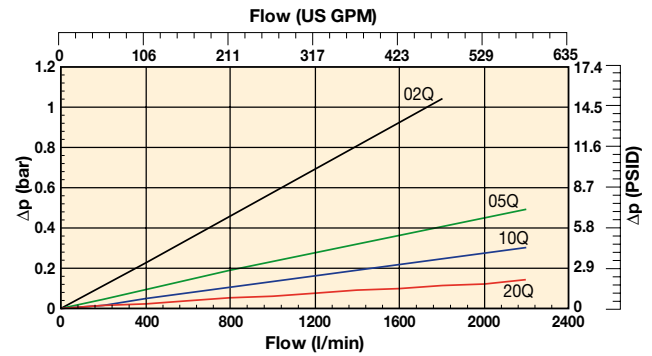

BGT2400 (Element length code 18)

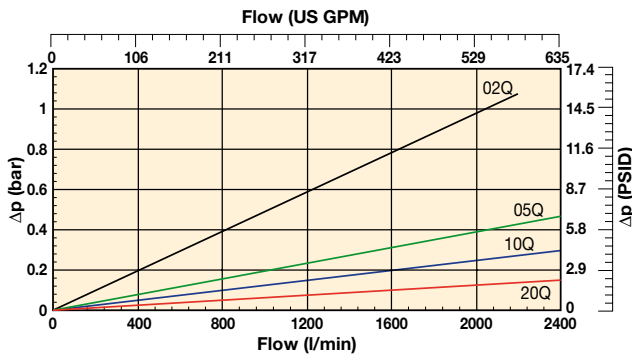

Pressure Drop Curves (cellulose and stainless steel media)

BGT390 (Element length code 11)
Cellulose & Stainless steel media

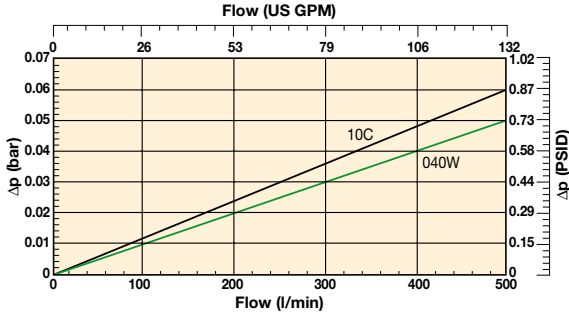

BGT390 (Element length code 11)
Cellulose & Stainless steel media

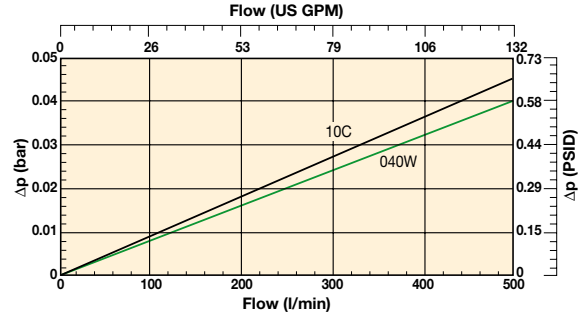

BGT600 (Element length code 13)
Cellulose & Stainless steel media

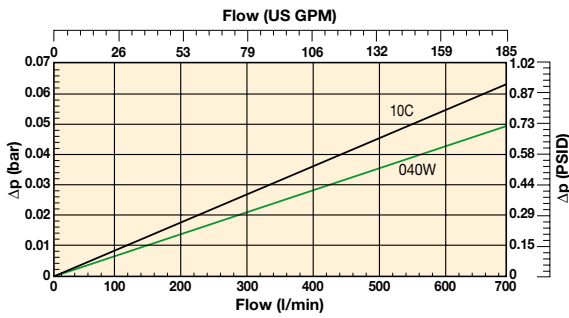

BGT800 (Element length code 14)
Cellulose & Stainless steel media

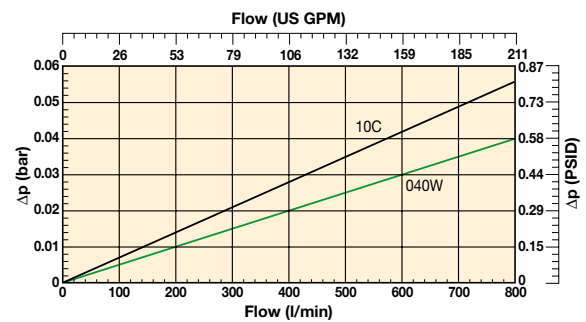

BGT1000 (Element length code 15)
Cellulose & Stainless steel media

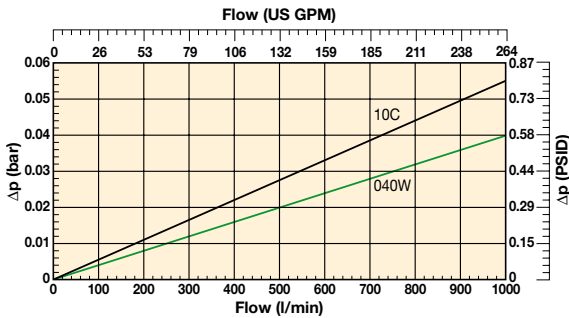

BGT1500 (Element length code 16)
Cellulose & Stainless steel media

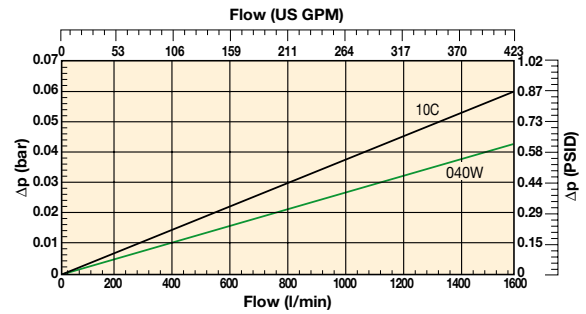

BGT2000 (Element length code 17)
Cellulose & Stainless steel media

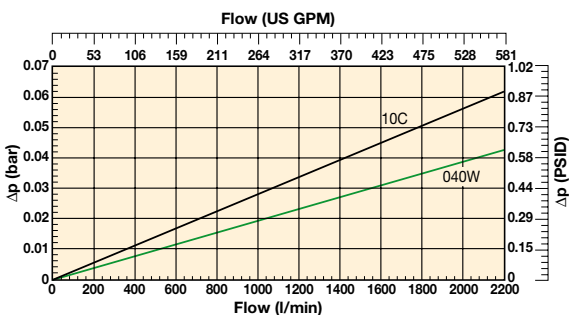

Cellulose and stainless steel media
Example: BGT2000 Filter Element Length 17 - cellulose and stainless steel media



BGT Series

Tanktop Mounted Return Line Filters

Ordering Information

Standard products table

Part number	Supersedes	Flow (l/min)	Model number	Element length	Media rating (µ)	Seals	Indicator	Bypass settings	Ports	Included options	Replacement elements	Supersedes
BGT1210QLBPER323	BGTS500-S2 TXWL8C-10 T B15 M	500	BGT500	Length 12	10	Nitrile	Plugged	1.5 Bar (22 Psi)	2"SAE-3000 PSI	Diffuser type T	937859Q	TXWL8L-10
BGT1220QLBPER323	BGTS500-S2 TXWL8C-20 T B15 M	500	BGT500	Length 12	20	Nitrile	Plugged	1.5 Bar (22 Psi)	2"SAE-3000 PSI	Diffuser type T	937868Q	TXWL8L-20
BGT1510QLBPER483	BGTS1000-S3 TXWL12-10 T B15 M	1000	BGT1000	Length 15	10	Nitrile	Plugged	1.5 Bar (22 Psi)	3"SAE-3000 PSI	Diffuser type T	937862Q	TXWL12-10
BGT1520QLBPER483	BGTS1000-S3 TXWL12-20 T B15 M	1000	BGT1000	Length 15	20	Nitrile	Plugged	1.5 Bar (22 Psi)	3"SAE-3000 PSI	Diffuser type T	937865Q	TXWL12-20
BGT1710QBPER483	BGTS2000-S3 TXW14-10 T B15 M	2000	BGT2000	Length 17	10	Nitrile	Plugged	1.5 Bar (22 Psi)	3"SAE-3000 PSI	Diffuser type T	937772Q	TXW14-10B
BGT1720QBPER483	BGTS2000-S3 TXW14-20 T B15 M	2000	BGT2000	Length 17	20	Nitrile	Plugged	1.5 Bar (22 Psi)	3"SAE-3000 PSI	Diffuser type T	937805Q	TXW14-20B

Note: Filter assemblies ordered from the product configurator below are on extended lead times. Where possible, please make your selection from the table above.

Product configurator

Configurator examples filter including LEIF® element

Box 1	Box 2	Box 3	Box 4	Box 5	Box 6	Box 7	Box 8
BGT	15	05QL	B	S1	E	R48	C

Configurator examples filter including conventional element

Box 1	Box 2	Box 3	Box 4	Box 5	Box 6	Box 7	Box 8
BGT	18	02Q	B	S4	E	3R20	4

Code	Filter type	Degree of filtration					
BGT	Housing	Element media					
	BGT390	Glass fibre					
	BGT500	Microglass III (for disposable elements)					
	BGT600	Cellulose					
	BGT800	Ecoglass III (for LEIF® elements)					
	BGT1000	Wire mesh					
	BGT1500	Abs. rating					
	BGT2000	040W					
	BGT2400	LEIF® element					
			10C	02Q	05Q	10Q	20Q
			02QL	05QL	10QL	20QL	

Seal type	Code
Nitrile	B
Fluorelastomer	V
Neoprene	on request

Indicator	Code
Pressure gauge, setting 1.2 bar, M10x1	G1
Pressure gauge, setting 1.2 bar, G1/4 for dual port head	G2
Pressure switch 42V, 1.2 bar setting, NO/NC, M10x1	S1
Pressure switch 42V, 1.2 bar setting, NO with G1/4 BSP	S2
Pressure switch 42V, 1.2 bar setting, NC with G1/4 BSP	S3
Pressure switch 250V, NO/NC with G1/4	S4
Pressure switch 220V, NO/NC with M10	S5
No indicator, indicator ports not machined	On request
No indicator, indicator port B plugged	P
Other settings for indicators / gauges on request	on request

Bypass valve	Code
0.8 bar	B
1.5 bar	E
2.0 bar for BGT-3 series (length 11 and 12)	H
Blocked bypass	X
Other bypass settings	on request

Note: For all dual head ports for BGTS apply G1/4 connection for indicators

Filter connection	Code
2" SAE BGT length 11 and 12	R32
3" SAE BGT Length 13 and larger	R48
1x2" SAE Flanged + 2 x 1 1/4" SAE Flanged for BGT Length 11 and 12	R32M
3x1 1/4" SAE Flanges + 1x 1/2" SAE for BGT Length 13 and larger	3R20

Options	Code
No diffuser required	1
Diffuser type T with perforated plate area	3
Diffuser type P without perforated plate area	4
No magnets	5
Plugged filling port	8
Diffuser type T and no magnets	A
Diffuser type P and no magnets	B
Diffuser type T, no magnets, plugged filling port	C
Diffuser type P, no magnets, plugged filling port	D
Diffuser type T, magnets and filling port	E
Diffuser type P, magnets and filling port	F
Air tight diffuser type T	G
Air tight diffuser type P	H
Other combinations	on request
ATEX certified* (Category 2, non-electrical equipment)	EX

Highlights Key (Denotes part number availability)

123	Item is standard
123	Item is standard green option
123	Item is semi standard
123	Item is non standard

Note 1: Part numbers featured with bold highlighted codes will ensure a 'standard' product selection.

Note 2: Alternate displayed part number selection will require you to contact Parker Filtration for availability.

Note 1*: For ATEX classified filters add EX after the code.

ATEX certified filters with electrical indicator are available on request.

Visual indicators are classified as Category 2, non electrical equipment.

Filter assemblies with EX code will be supplied with a dedicated name plate.

Pls consult Parker Filtration for any questions related to the classification of our products.



Ordering Information (cont.)

Degree of filtration						Media code
Average filtration beta ratio β (ISO 16889) / particle size μm [c]						
$\beta(x)(c)=2$	$\beta(x)(c)=10$	$\beta(x)(c)=75$	$\beta(x)(c)=100$	$\beta(x)(c)=200$	$\beta(x)(c)=1000$	
% efficiency, based on the above beta ratio (βx)						
50.0%	90.0%	98.7%	99.0%	99.5%	99.9%	02Q/02QL
N/A	N/A	N/A	N/A	N/A	4.5	05Q/05QL
N/A	N/A	4.5	5	6	7	10Q/10QL
N/A	6	8.5	9	10	12	20Q/20QL
6	11	17	18	20	22	

Supersedes spare element table					
BGT390	TXWL8A-2	TXWL8A-5	TXWL8A-10	TXWL8A-20	
Part number spare element	937832Q	937843Q	937858Q	937869Q	
BGT500	TXWL8C-2	TXWL8C-5	TXWL8C-10	TXWL8C-20	
Part number spare element	937833Q	937842Q	937859Q	937868Q	
BGT600	TXWL10-2	TXWL10-5	TXWL10-10	TXWL10-20	
Part number spare element	937834Q	937841Q	937860Q	937867Q	
BGT800	TXWL11-2	TXWL11-5	TXWL11-10	TXWL11-20	
Part number spare element	937835Q	937840Q	937861Q	937866Q	
BGT1000	TXWL12-2	TXWL12-5	TXWL12-10	TXWL12-20	
Part number spare element	937836Q	937839Q	937862Q	937865Q	
BGT1500	TXWL13-2	TXWL13-5	TXWL13-10	TXWL13-20	
Part number spare element	937837Q	937838Q	937863Q	937864Q	

Supersedes spare element table						
BGT390	TXX8A-10-B	TXW8A-2-B	TXW8A-5-B	TXW8A-10-B	TXW8A-20-B	ST8A-40-B
Part number spare element	937728	937742Q	937763Q	937778Q	937799Q	937813
BGT500	TXX8C-10-B	TXW8C-2-B	TXW8C-5-B	TXW8C-10-B	TXW8C-20-B	ST8C-40-B
Part number spare element	937729	937741Q	937764Q	937777Q	937800Q	937812
BGT600	TXX10-10-B	TXW10-2-B	TXW10-5-B	TXW10-10-B	TXW10-20-B	ST10-40-B
Part number spare element	937730	937740Q	937765Q	937776Q	937801Q	937811
BGT800	TXX11-10-B	TXW11-2-B	TXW11-5-B	TXW11-10-B	TXW11-20-B	ST11-40-B
Part number spare element	937731	937739Q	937766Q	937775Q	937802Q	937810
BGT1000	TXX12-10-B	TXW12-2-B	TXW12-5-B	TXW12-10-B	TXW12-20-B	ST12-40-B
Part number spare element	937732	937738Q	937767Q	937774Q	937803Q	937809
BGT1500	TXX13-R-10-B	TXW13-R-2-B	TXW13-R-5-B	TXW13-R-10-B	TXW13-R-20-B	ST13-40-B
Part number spare element	937733	937737Q	937768Q	937773Q	937804Q	937808
BGT2000	TXX14-10-B	TXW14-2-B	TXW14-5-B	TXW14-10-B	TXW14-20-B	ST14-40-B
Part number spare element	937734	937736Q	937769Q	937772Q	937805Q	937807
BGT2400	-	TXWH14-2-B	TXWH14-5-B	TXWH14-10-B	TXWH14-20-B	-
Part number spare element		937735Q	937770Q	937771Q	937806Q	

BGT Series Seal Kits

BGT Filter connection	Nitrile Seal kit
Port(s) Filter head	Part Number
2" SAE BGT length 11 and 12	2049010017
3" SAE BGT Length 13 and larger	2049010023
1x2" SAE Flanged + 2 x 1 1/2" SAE Flanged for BGT Length 11 and 12	918045048
3x1 1/2" SAE Flanges + 1x 1/2" SAE for BGT Length 13 and larger	2049010020