



DECKMA
HAMBURG

INSTRUCTION MANUAL

OMD-24 Series

15 ppm Bilge Alarm

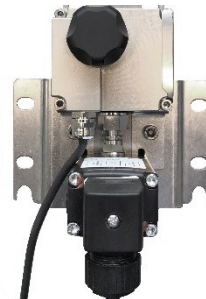
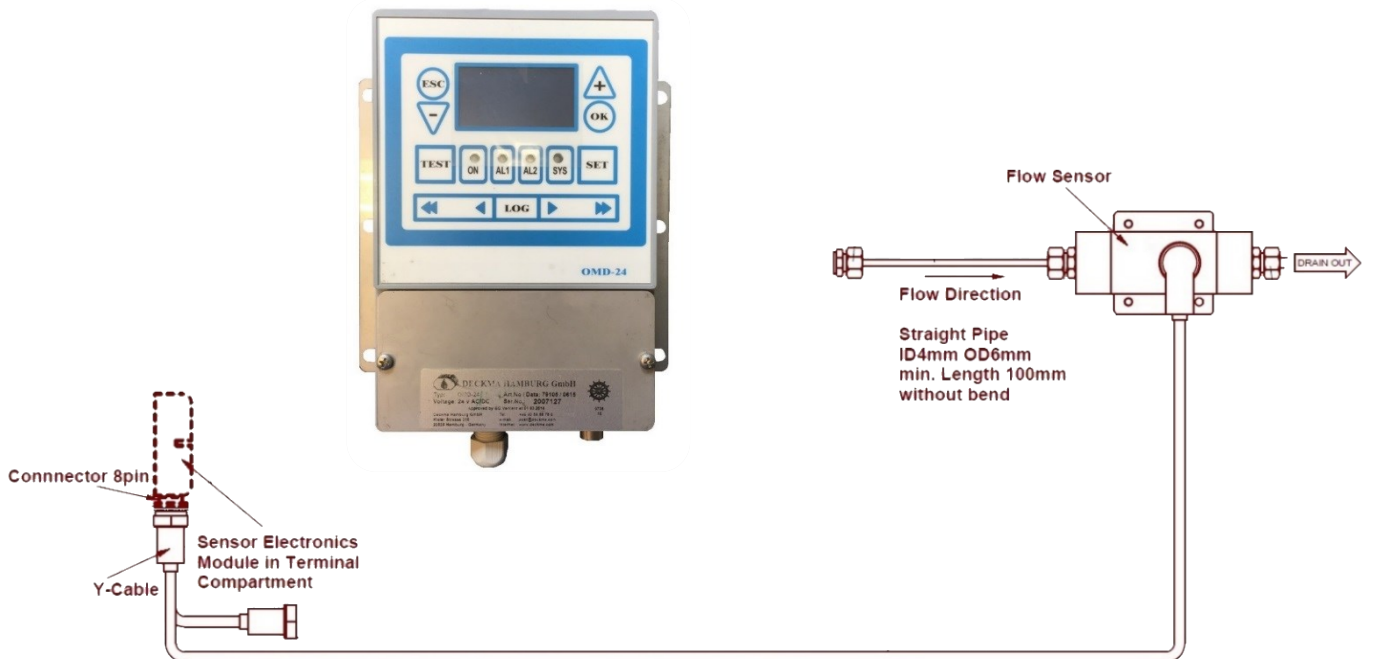

OMD-24 Series

- Electric Valve – OMD-24 EV
- Electric Valve Auto Clean – OMD-24 EVA
- Auto Clean – OMD-24 A
- Flow Control OMD-24 FC
- (Optional: Manual Cleaning Unit MCU)

We help to protect the Environment





DECKMA
HAMBURG

Usage of this instruction manual

This instruction manual will guide you how to use the OMD-24 Series. The instruction manual is split into sections. Every section handles a specific part of the OMD-24 Series. The first section gives you general information about the safety before using and servicing the OMD-24 Series. Please take notice on this section.

You will also find information about the construction and the installation of OMD-24 Series. The programming mode is explained in detail at the end of the instruction manual.

This instruction manual also contains information about the service support and our contact details. The symbols below will accompany for a better understanding.





Disposal



The crossed-out waste container icon on waste electrical or electronic device indicates that this device must not be disposed of with household waste at the end of its life. There are collection points available in your area for free. The addresses can be obtained from your municipality or local administration. You can also email us at post@deckma.com to find out further return options provided by our company.

Separate collection of waste electrical and electronic equipment (WEEE) is intended to prevent the re-use, recycling other forms of use of WEEE as well as to avoid adverse effects on the environment and human health from the disposal of potentially hazardous substances contained in devices.

Symbols

- This symbol is used for giving general advices.
- i This symbol is used to clarify a recommendation.
- ⚡ This symbol is used for giving advices about servicing.
-  This symbol is used to draw warning against hand injuries.
-  This symbol is used to show electrical voltage warnings.
-  This symbol is used to draw attention to hot surfaces.
-  This symbol is used for giving general warnings.
-  This symbol is used to draw attention to hazardous substances.



Safety hazard

Mechanical Risks

 Risk of hand injuries	While closing the front cover hand injuries could be possible.
--	--

Electrical Risks

 Electrical voltage warnings	Incorrect commissioning and wiring, touching live parts, and cable breakage or faulty components can lead to electrical hazards.
--	--

Thermal Risk

 Risk of scalding	High temperatures can occur on the surface of the measuring cell. Hot water may spill and cause scalding.
---	---

Chemical Risk

 Risk of chemicals	Material used during cleaning and maintenance can cause eye and skin irritation.
---	--

Risk reduction

Risks	Recommended reduction	Risk level (1)Low – (3)High
Risk of hand injuries.	While opening and closing the front cover care must be taken.	1
Electrical risks.	Works on the units should be only be done by a qualified person. Keep Terminal Cover closed at all times.	3
Risks of scalding.	It is recommended to wear protective clothing in the form of heat-resistant gloves and protective goggles, if high temperature sample is present.	1
High temperature risks.	Do not open the cell cap until the sample water has cooled down sufficiently. Stop any sample water flow prior to opening the head screw.	2
Unexpected movement of the wiper piston.	Close pressurized air supply before working on the Autoclean System or dismantling the Autoclean System.	2
Chemical Risk.	Material used for Cleaning and Maintenance may cause eye and skin irritation. Cleaning solution may cause health problems if ingested.	1
Risk of environmental damage.	Use instrument strictly within its specification. Keep instrument properly maintained.	1
Risk of health damage.	Do not touch or ingest any residue from sample stream.	2



DECKMA
HAMBURG

IMPORTANT NOTICE

Replacement components for 15 ppm Bilge Alarms

General

All monitors in our range are inspected and tested to the related International Maritime Organization IMO requirements at our factories prior to delivery.

In normal use the units should operate correctly and without fault over a long period of time requiring only small amounts of maintenance to be carried out as outlined in the instruction manual.

Service Exchange Units

In the event of a monitor malfunction due to electrical or electronic component failure it is our recommendation that a service exchange unit be ordered.

The defective instrument should be returned to our works within 30 days of supplying the service exchange unit, then only the repair charge is payable. Otherwise the whole cost of a service exchange unit becomes payable.

This procedure is by far the easiest and most cost-effective way of ensuring the monitor on board conforms to IMO resolution MEPC.107(49).

Remark

According to the MEPC.107(49) § 4.2.11 the units have to be checked at IOPP Certificate renewal survey by the manufacturer or persons authorized by the manufacturer. Alternatively, the unit may be replaced by a calibrated 15 ppm Bilge Alarm.

The OMD-24 Series are designed in that way, that only the Measuring Cell needs to be changed, as these units carry the Calibration Certificate. The Calibration Certificate with the date of the last calibration check should be retained onboard for inspection purposes.

If for some reasons the Computer Unit needs to be changed, it has made sure, that the memory card will remain on board for at least 18 months. The new Computer Unit will carry its own memory card. The old card can be inserted into the new unit only for reading. Writing is only possible with the card delivered with the new Computer Unit. For details see section 16.

Memory Card.

Warranty

Our warranty terms are 12 months after installation but maximum 18 months after delivery ex works. The maker undertakes to remedy any defect resulting from faulty materials of workmanship except wearing parts.

The maker's obligation is limited to the repairs or replacement of such defective parts by his own plant or one of his authorized service stations.

The purchaser shall bear the cost and risk of transport of defective parts and repaired parts supplied in replacement of such defective parts.

i

ANY DISMANTLING OR BREAKING OF A SEAL WILL VOID THE WARRANTY.



Content:

Usage of this instruction manual	1
Disposal	1
Symbols	1
Safety hazard	2
Risk reduction	2
Revision	8
1. Introduction.....	9
2. Important Notes	11
3. Principle of operation	12
3.1 Touch Panel.....	12
3.2 Measuring Principle.....	12
3.3 Display Visualization.....	12
3.4 Alarms	13
3.5 Adjustment	13
3.5.1 Limited Adjustment Alarm Set Point.....	14
3.6 Active Current Interface.....	14
3.7 Inputs.....	14
3.8 EV (Electric clean water Valve)	14
3.9 Automatic Cell Cleaning Device	15
3.10 MCU (Manual Cleaning Unit).....	15
3.11 Features	16
3.12 Internal Back-Up Lithium Thionyl Chloride Battery	16
4. OMD-24.....	17
4.1 Specification OMD-24.....	18
4.2 OMD-24 Construction	19
4.3 OMD-24 Installation	20
4.4 OMD-24 Piping	21
4.5 OMD-24 Cabling	22
5. OMD-24 EV	23
5.1 Specification OMD-24 EV	24
5.2 Construction OMD-24 EV	25
5.3 Installation OMD-24 EV	26



5.4	Piping OMD-24 EV	27
5.5	Cabling OMD-24 EV	28
6.	OMD-24 EVA.....	29
6.1	Specification OMD-24 EVA	30
6.2	Construction OMD-24 EVA	31
6.3	Installation OMD-24 EVA	32
6.4	Piping OMD-24 EVA	33
6.5	Cabling OMD-24 EVA	34
7.	OMD-24 A.....	35
7.1	Specification OMD-24 A	36
7.2	Construction OMD-24 A	37
7.3	Installation OMD-24 A	38
7.4	Piping OMD-24 A	39
7.5	Cabling OMD-24 A	40
8.	OMD-24 FC (Conversion-Kit).....	41
8.1	Specification OMD-24 FC (Conversion-Kit)	42
8.2	Construction.....	43
8.3	Installation	44
8.3.1	Electrical Installation Step-By-Step	44
8.3.2	Typical Piping Installation	46
8.4	FC Principle of operation.....	47
8.4.1	FC (Flow Control).....	47
8.4.2	Description of Sensor-PCB LEDs.....	47
9.	Cleaning Devices	48
9.1	Manual Cleaning Unit (MCU)/ Automatic Cell Cleaning Device	48
9.1.1	Flow rate regulation on MCU, Auto Clean System	48
10.	Terminals description	49
10.1	External Control System.....	51
11.	Power Supply	52
12.	Commissioning.....	53
12.1	Electrical and Piping.....	53
12.2	Instrument Start-Up Sequence	54
12.3	Flow rate Adjustment	54
12.4	System Settings	56
12.5	Auto Clean Control Unit	56



DECKMA

HAMBURG

12.5.1	Pressure Regulation	57
12.5.2	Using standard drainage SS	57
13.	OMD-24 Series Operating instructions	58
13.1	Cleaning Options	59
14.	Operator Maintenance	60
14.1	General Test	60
14.2	Normal Operation	60
14.3	Cleaning Process	61
14.4	Intensive Cleaning	61
14.5	System Test	61
14.6	Data Logger Checking	62
14.7	MCU and Automatic Cell Cleaning Device	62
14.8	Maintenance Recommendations	63
15.	Programming Mode	64
15.1	Buttons	65
16.	Memory Card	66
16.1	OMD-CR Memory Card Reader	67
17.	Fault finding	68
17.1	Automatic Cell Cleaning Unit Fault Finding	70
18.	Calibration	71
18.1	OMD-24 Series	71
18.2	Calibration and Repeatability Check	71
18.3	Function Test at Classification Survey and Port State Control	72
19.	OMD-24 Series with 5 ppm Alarm Set Point	73
20.	Spare Parts	74
20.1	Recommended On Board Spares	75
21.	Optional Equipment	76
22.	REMARKS	77
23.	Appendix I	78
23.1	Navigation Buttons	78
23.2	Functional Buttons	79
23.2.1	Functional Button "TEST"	79
23.2.2	Functional Button "ON"	80
23.2.3	Functional Buttons AL1/ AL2/ SET	82
23.2.4	Functional Button "SYS"	84



DECKMA

HAMBURG

23.3	Data Logger Operation Buttons	85
23.4	Activating the Memory Card	86
23.5	Software additional information	87
24.	Appendix III.....	91
24.1	ALARMS	91
25.	Appendix IV.	92
25.1	Operator Maintenance Quick Checklist	92
26.	Appendix V	93
26.1	Servicing and Cleaning Manual.....	93
	Index.....	106
	List of Figures	107
	Sales & Service Locations	108
	Notes:	109
	Type Approved by:	110



Revision

Document-Name	Revision No.	Notation	Date
OMD-24 Series	R07_20221109		09.11.2022



1. Introduction

The OMD-24 Series Bilge Alarm Units have been designed specifically for use in conjunction with 15 ppm oil-water separator units and have a specification and performance which exceeds the requirements of the International Maritime Organization IMO specifications for 15 ppm Bilge Alarms contained in Resolution MEPC.107 (49).

The units are supplied with 2 works-adjusted alarms at 15 ppm. Set points from 1 ppm to 15 ppm are possible and can be adjusted on site at any time by using the buttons at the front panel.

If an alarm set point is exceeded, the alarms are visible at the front panel and the appropriate relays are switched. In case of malfunction the “**SYS LED**” at the front panel will change from blinking green to permanent red.

For the data logging function, the unit requires a status input from the separator.

A 0(4) - 20 mA signal output (equal to 0 - 30 ppm) is available for driving a recorder or external meter.

By request the OMD-24 Series are also available with 5 ppm alarm set point. Additionally, instrument versions equipped with a Measuring Cell Cleaning Unit or an Automatic Cell Cleaning Device are available.

OMD-24 Series generally consist of a Computer Unit, a Measuring Cell, and further equipment (e.g. Valve Assembly, Electrical Valve, Flow Control, and Automatic Cell Cleaning Device).

The Computer Unit contains the display PCB with the data logger and the terminals for external connections.

The Measuring Cell is built out of an anodized all-aluminum body with inlet and outlet block made from stainless steel. This rugged cell contains optics and electronics and is connected with the Computer Unit via a plugged data cable. The Measuring Cell is mounted onto a valve support, which holds the valve assembly, too. Sample water and clean water usage are controlled by an electric Switchover Valve. This assembly is connected to the measuring cell by a push-in connector.

The Measuring Cell should be positioned vertical.

The OMD-24 units can be mounted on wall or as bulkhead installation. It is also possible to split the computer unit from the Measuring Cell if the available space is not sufficient. Optionally a connection cable for up to 5 m distance from Computer Unit to Measuring Cell is available.

The OMD-24 Series should be located as close as possible to the oily water separator to minimize response delays. According MEPC.107(49) the layout of the installation should be arranged so that the overall response time (including the response time of the 15 ppm Bilge Alarm, which is less than 5 sec.) between an effluent discharge from the 15 ppm Bilge Separator exceeding 15 ppm, and the operation of the Automatic Stopping Device



DECKMA
HAMBURG

preventing overboard discharge, should be as short as possible and in any case not more than 20 sec.

Mount the OMD-24 Series instruments by means of M6 or M8 screws on to a rigid vertical surface or frame and preferably with the display panel of the monitor at user convenience. For service and maintenance sufficient space to all sides should be available.

Care must be taken at mounting of the pipes connections to avoid any torsion of the housing and damage of the instrument.

For separator discharge pipes, up to 75 mm OD a standard "T"-type junction of the welded or screwed type is satisfactory for the tapping point. For the separator discharge pipes of 80 mm OD and above a sample probe should be employed which protrudes into the discharge piping by approx. 25 % of the ID of the pipe.

If connection to a vertical section of the separator outlet piping is impractical, the tapping may be made into the side of the horizontal pipe. Avoid top or bottom entry.

Electrical connections are made through the metric cable gland openings prepared underneath the instrument. Not all openings may be free. The electrical connections are located inside the computer housing.

The Units must be connected to the mains supply via a suitable rated and approved fused isolator unless such fusing / isolation is provided by associated equipment. When fitted, the isolator should be close, readily accessible and marked as to function.

Close the terminal cover completely after electrical installation. Water and humidity inside the instrument may result in corrosion and malfunction.



If the instrument is operated at high voltages, additional care has to be taken to provide reliable ground connections. Ground (PE) must be connected direct to the PE terminal or, if this is not sufficient according local rules, to the computer housing (PE bolt inside, right side).



DECKMA
HAMBURG

2. Important Notes

- a) This equipment must be installed and operated in strict accordance with the instructions contained in this instruction manual. Failure to do so will impair the protection provided.
- b) Installation and servicing must be undertaken by a competent and suitably skilled person.
- c) The equipment must be connected to the ground according relevant requirements.
- d) The unit must be isolated from the electrical supply before any maintenance of the equipment is attempted.
- e) All national or local codes of practice or regulations must be verifying and, where applicable, are deemed to take precedence over any directive or information contained in this instruction manual.
- f) In case of freezing conditions, the Measuring Cell should be emptied completely. Some components mentioned in this instruction manual may not be present on the instrument on site, and/or the instrument may have additional components.
- g) Technical specifications are subject to change without notification.
- h) If uncertain how to proceed, contact the maker.



3. Principle of operation

3.1 Touch Panel

The OMD-24 Series Touch Display consists of several buttons and LEDs. Each button/LED has its own specific function. (For more information see 23. Appendix I.).

A.	+ button
B.	OK button
C.	AL1/2 button/ LED
D.	SYS button/ LED
E.	SET button
F.	Arrow Slider
G.	LOG button
H.	TEST button
I.	ON button/ LED
J.	- button
K.	ESC button
L.	Display

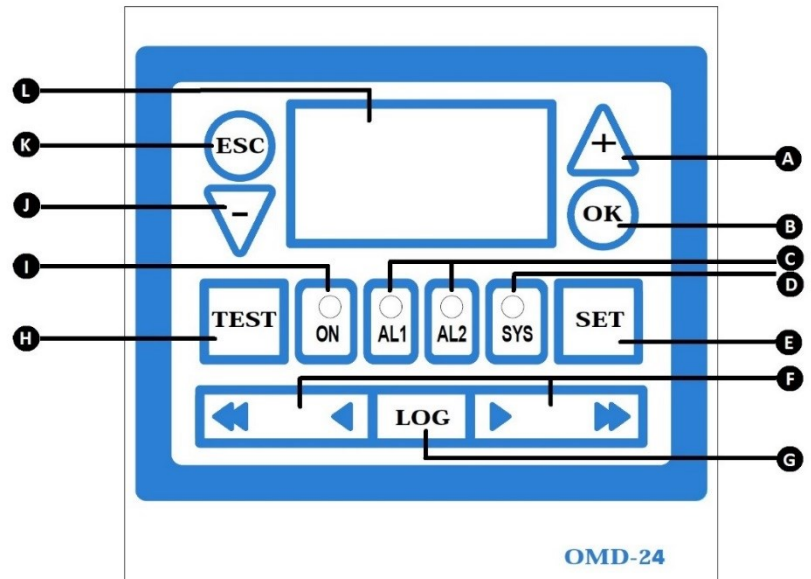

Figure 1 Touch Panel

3.2 Measuring Principle

An optical sensor array measures a combination of light scattered and absorbed by oil droplets in the sample stream. The sensor signals are processed by a microprocessor to produce linearized output.

If an alarm (set point from 1 ppm to 15 ppm) occurs, the two oil alarm relays are activated after the adjusted time delay.

The microprocessor continuously monitors the condition of the sensor components and associated electronics to ensure that calibration accuracy is maintained over time and extremes of environmental conditions.

3.3 Display Visualization

The display visualizes the oil content status of the units. Using the buttons, it is also possible to see information about the settings.



3.4 Alarms

The units contain two independent oil alarm circuits. From the manufacturing both alarms are set to 15 ppm (according IMO). The set points can be changed according to the requirements on site, to any point between 1 ppm and 15 ppm. An alarm point setting above 15 ppm is not possible. The adjustment can be done in the programming mode as described in the appendix (See section 23.2.3 Functional Buttons AL1/ AL2/ SET).

Both alarm circuits are also related to an alarm LED on the front panel.

In case of malfunction the **"SYS LED"** will indicate some type of internal fault of the unit. This LED is flashing green in normal conditions and is red in alarm conditions.

Additional to the alarm LEDs each alarm circuit is equipped with a relay with potential free alarm contacts. These contacts can be used for external processing of the signal or for control of further functions. The alarm circuits contain two independent alarm delays, which can be set separately. In this mode, also the individual adjustment of the time delays for the alarms can be done. An alarm delay is set to 4 sec. The flow sensor is downstream of the Measuring Cell.

If a malfunction or failure of the power supply occurs, relays (both alarm relays) will switch to alarm condition. (See Section 24. Appendix III. for an easily understandable example). If the unit is off, both relays will be in alarm condition.

3.5 Adjustment

The unit is delivered with a works calibration according the IMO requirements. A customer calibration on board is not permitted. This has to be done according IMO Regulations by the manufacturer or persons authorized by the manufacturer.

The units contain two alarm delays. Alarm 1 is to be used for signing purpose and the delay can be set from 1 sec. to 9 min. Alarm 2 is limited to control overboard discharge. The Alarm 2 delay can be set from 1 sec. to 10 sec. max.

The "Zero" point is also works calibrated and is adjustable to ± 5 ppm.

On site by using the programming mode (See Section 23.2.3 *Functional Buttons AL1/ AL2/ SET*) and clean water you can adjust following points:

Settings	Min.	Max.	Default.
Alarm 1/ Alarm 2	1 ppm	15 ppm	15 ppm
Delay 1	1 sec.	9 min.	2 sec.
Delay 2	1 sec.	10 sec.	10 sec.
Offset	-5 ppm	5 ppm	0 ppm

Table 1



DECKMA
HAMBURG

3.5.1 Limited Adjustment Alarm Set Point

By request units with alarm set point of 5 ppm max. are available. (For more information, read section 19. OMD-24 Series with 5 ppm Alarm Set Point).

3.6 Active Current Interface

The active current interface represents a combination of measurements and interpretations. The active current interface is adjustable to 0 to 20 mA or to 4 to 20 mA. This complies the oil content from 0 to 30 ppm. In case of malfunction e.g. “EE” means 20 mA.

The maximum open-load voltage is about 5 V and it is strongly recommended not to burden 150 Ω external load.

3.7 Inputs

The unit also has four active inputs, which can be used separately as well.

- a) Separator Input is dedicated to be used according the MEPC.107 (49).
- b) Reserve Input reserved for future use.
- c) Optionally there is an active input for external flow switch (FLOW). The Unit will be in alarm condition, whenever Terminals are opened/ disconnected. Normally this input is delivered with a link.
- d) An Input for fresh water switchover for units with an Electric Valve is available.

3.8 EV (Electric clean water Valve)

The OMD-24 EV is designed with an Electric Switchover Valve to switch the instrument from the sample stream to supply of clean, oil free water. Whenever fresh water is allowed to flow to the Measuring Cell, the OMD-24 EV will switch over to alarm condition as required by MEPC.107(49), and it will also continue to display the measurement result. The OMD-24 EV setup replaces the manual valve setup for the standard OMD-24, and also allows remote flushing.



3.9 Automatic Cell Cleaning Device

The Automatic Cell Cleaning Device is a useful addition to the OMD range of monitoring equipment. It was developed in order to ease the task of routine cleaning as described in the manuals and to ensure that the measuring system of the monitoring equipment is kept in good working order.

Auto Clean System provides a truly automatic cleaning device which is designed to run only when the system is on. The Auto Clean System consists of:

- a) Cylinder/ piston assembly for physical cleaning of the sample cell.
- b) Air Regulation Filter Unit (different makes and types may be used).
- c) Auto Clean logic control with valve. It determines the frequency of the cleaning cycles.

i

The Automatic Cell Cleaning Device does not replace the operator maintenance schedule but can reduce the maintenance workload.

3.10 MCU (Manual Cleaning Unit)

Optionally the instruments can be fitted with a Manual Cleaning Unit. The Manual Cleaning Unit allows to clean the Sample Glass Tube without opening the Cell Cap, and without interrupting the normal sample flow. Maintenance is made easier with the MCU. Please note that operating the MCU may set the instrument to alarm condition for a few seconds.



3.11 Features

OMD-24 Series Features	OMD-24	OMD-24 EV	OMD-24 EVA	OMD-24 A	OMD-24 FC
MEPC.107(49).	✓	✓	✓	✓	✓
Solid suppression capability	✓	✓	✓	✓	✓
Low maintenance	✓	✓	✓	✓	✓
Easy installation	✓	✓	✓	✓	✓
Constant readiness	✓	✓	✓	✓	✓
Low spare part stock holding	✓	✓	✓	✓	✓
Easy settings via menu	✓	✓	✓	✓	✓
Works adjustment	✓	✓	✓	✓	✓
Electric Valve		✓	✓		✓
Auto Clean System			✓	✓	✓
MCU (<i>optional</i>)	✓	✓			✓
Robust Construction	✓	✓	✓	✓	✓

Table 2

3.12 Internal Back-Up Lithium Thionyl Chloride Battery

Further the PCB of the computer unit is equipped with an internal back-up lithium thionyl chloride battery, for the internal clock, if the computer unit is out of power.

The internal lithium battery of the OMD-24 Computer Unit has a low self-discharge (<1% per year) and should have a calculated lifetime over 20 years, if handled properly.



In case the lithium thionyl chloride battery fails, it must be replaced by a qualified technician in our factory. Please do **not** exchange the lithium battery by yourself. The battery cannot be replaced with a standard battery.

See Section Disposal for more information.



DECKMA
HAMBURG

4. OMD-24

The OMD-24 is the standard version of the OND-24 Series. The OMD24 consists of Computer Unit and a Measuring Cell, which is equipped with two handles to control sample water flow and clean water usage.



4.1 Specification OMD-24

Range:	0 – 30 ppm, Trend indication 50 ppm
Accuracy:	According IMO MEPC. 107(49)
Linearity:	0 – 30 ppm better than $\pm 2 \%$
Display:	Yellow Graphic Display
Power Supply:	24 V AC or DC +/- 10%
Consumption:	< 5 VA
Alarm Points 1 + 2:	Adjustable between 1 – 15 ppm* (Works adjustment 15 ppm)
Alarm 1 Operating Delay: (for annunciation purpose)	Adjustable between 1 – 540 sec. (Works adjustment 2 sec.)
Alarm 2 Operating Delay: (for control purposes)	Adjustable between 1 – 10 sec. (Works adjustment 10 sec.)
Alarm Indication: (Alarm 1, 2, System Fault)	Red LEDs
Alarm Contact Rating: (Alarm 1, 2, System Fault)	Potential free 1 pole change over contacts, 3 A / 240 V.
Output Signal:	0 – 20 mA or 4 – 20 mA selectable, ext. Load < 150 Ω .
Sample/ Fresh Water pressure:	0 – 10 bar recommended range of installation
Sample Flow:	Approx. 0.1 – 3 l/min
Sample Water Temperature:	+1 to +65 °C
Ambient Temperature:	+1 to +55 °C
Roll:	Up to 45°
Size: Computer Unit Measuring Cell Assembly	185 mm W x 210 mm H x 65 mm D 140 mm W x 160 mm H x 65 mm D
Distance Computer Unit to Measuring Cell:	Up to 0.5 m
Weight: (with Measuring Cell)	2.5 kg
Degree of Protection:	IP 65
Pipe connections:	R ¼" Female
→ Technical specifications are subject to change without notification.	

*By request the alarm set point can be set to 5 ppm max.



4.2 OMD-24 Construction

The OMD-24 consists of a Computer Unit and a Measuring Cell, which is equipped with two handles, which control sample water flow and clean water usage. This assembly is connected to the measuring cell by a push-in.

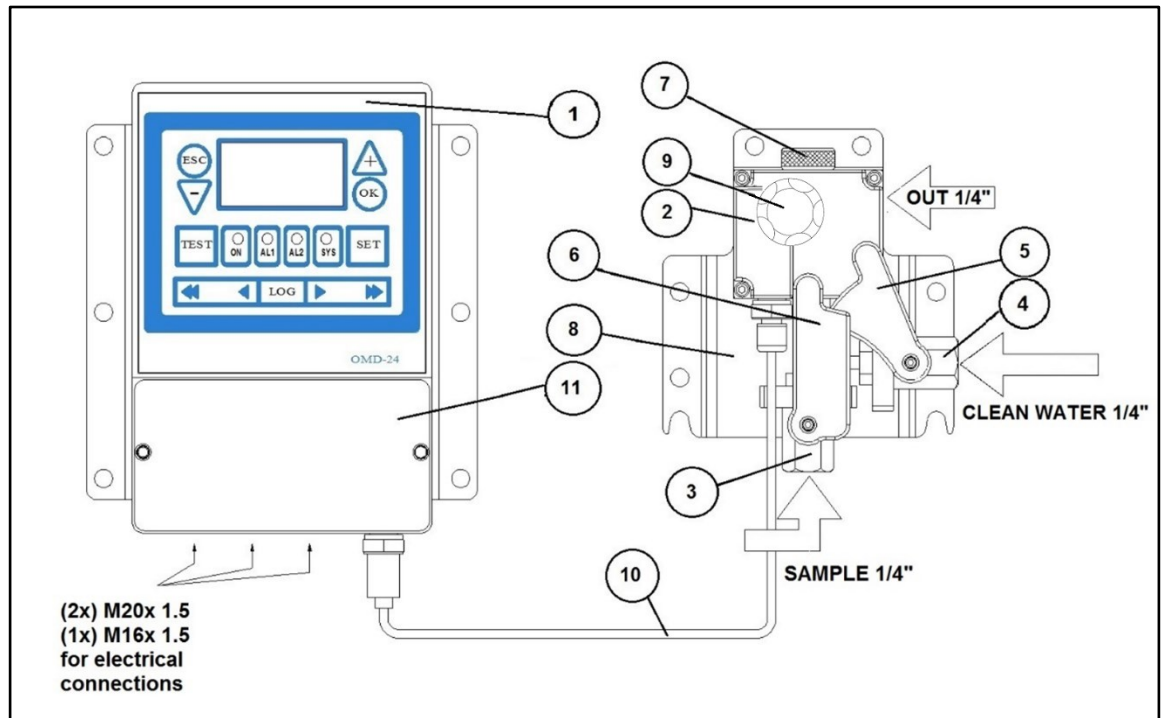

Figure 2. Construction OMD-24

- | | | |
|----------------------|-----------------------|-------------------------|
| 1. Computer Unit | 5. Clean Water Handle | 9. Desiccator Cap |
| 2. Measuring Cell | 6. Sample Handle | 10. Communication Cable |
| 3. Sample Valve | 7. Cell Cap | 11. Terminal Cover |
| 4. Clean Water Valve | 8. Valve Support | |



4.3 OMD-24 Installation

Please refer to the following drawing for mounting dimensions.

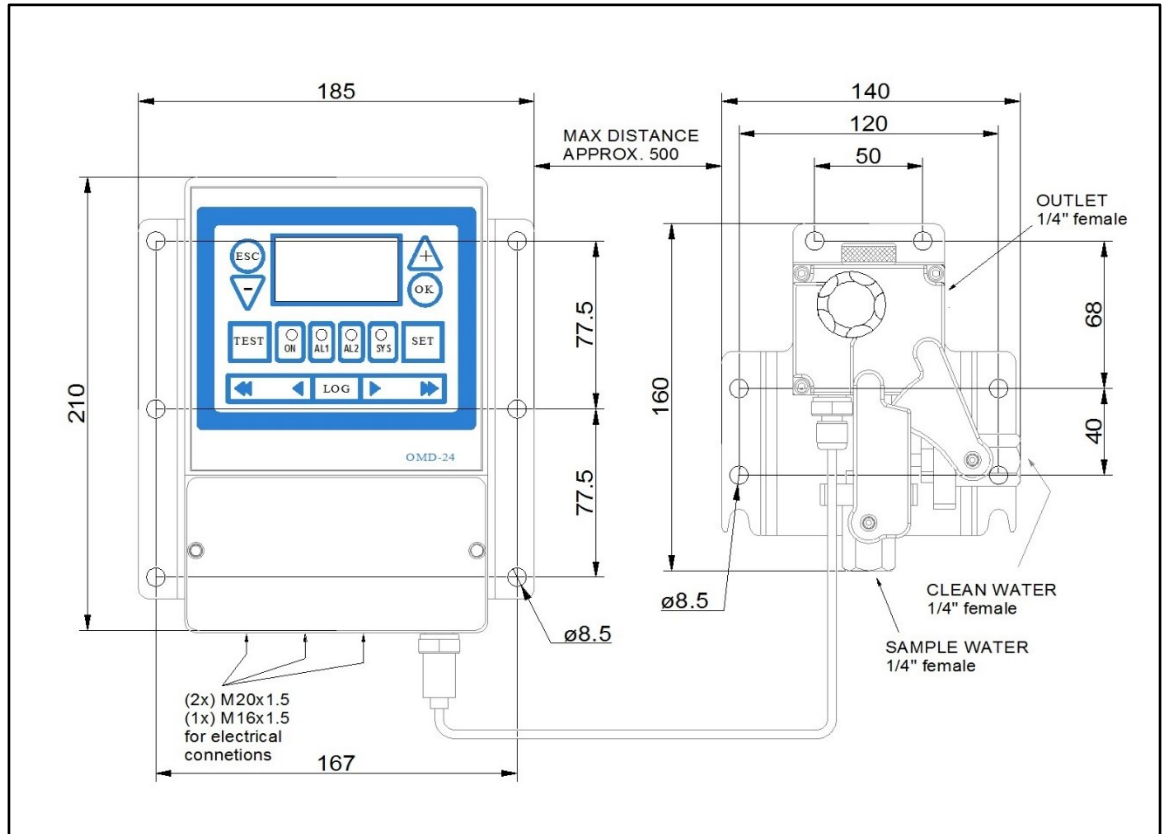

Figure 3. Installation OMD-24



4.4 OMD-24 Piping

Connect the OMD-24 Monitor to the sample point of the oily-water separator outlet and to a source of oil free water employing 6 mm, 10 mm OD copper or stainless-steel pipe. The sample point should be located on a vertical section of the separator outflow piping to minimize the effects of any entrained air. The tapping point should be at a level above the outlet of the monitor to ensure a proper sample flow rate.

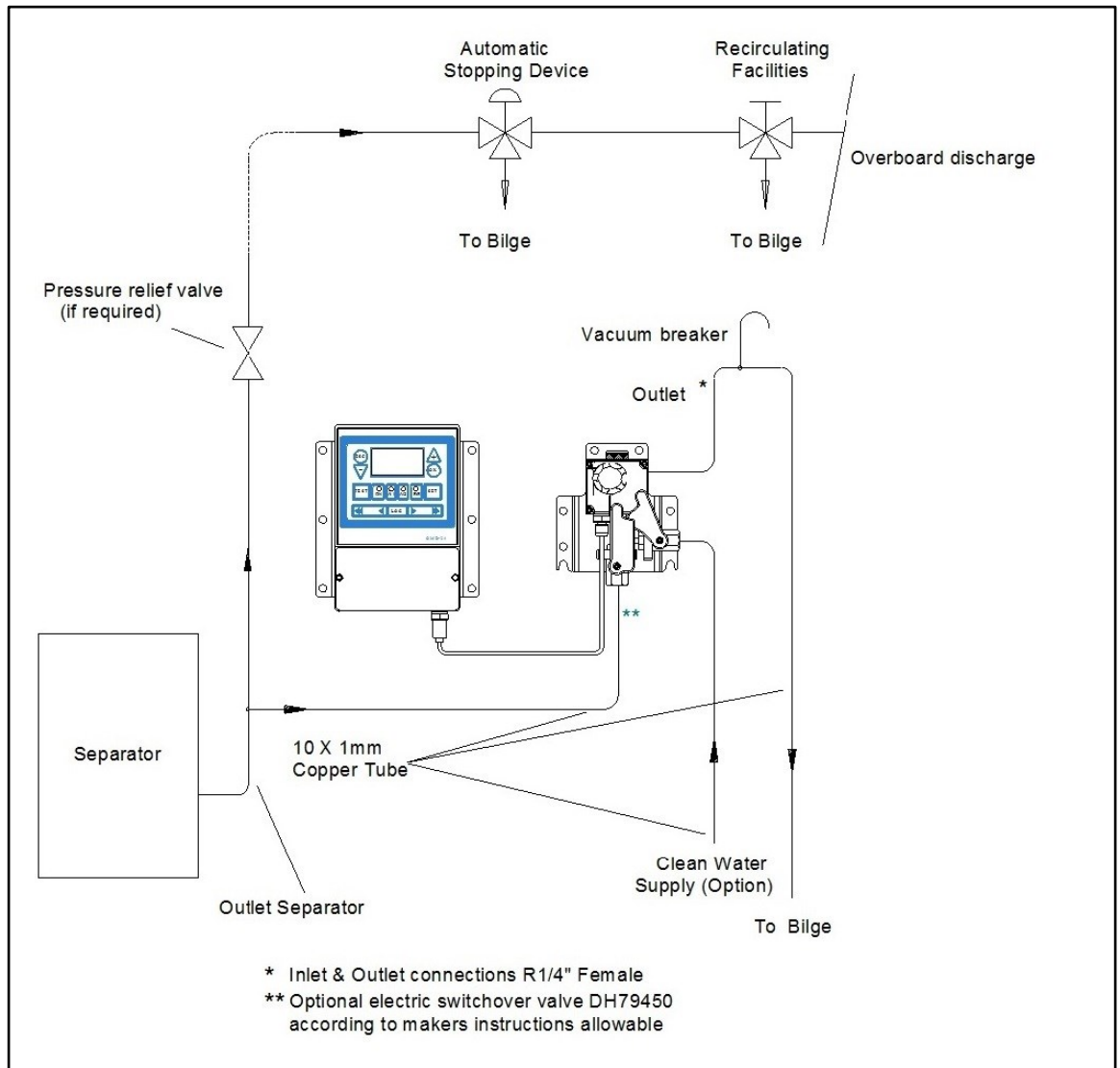

Figure 4. Piping OMD-24



4.5 OMD-24 Cabling



The following figures illustrate a bottom view of the OMD-24 Computer Units as delivered.

Use the M20 opening for the power supply voltage. Remove the plastic screw to attach the cable gland. Further openings can also be used with a cable gland.

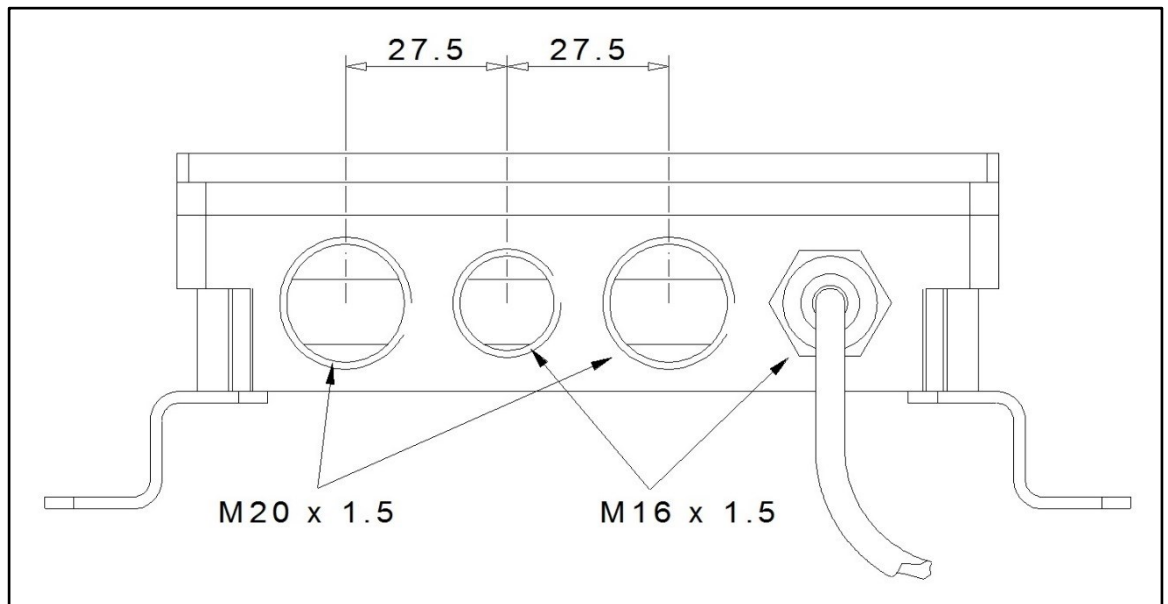

Figure 5. Bottom View: OMD-24



DECKMA
HAMBURG

5. OMD-24 EV

The OMD-24 EV is designed with an Electric Switchover Valve to switch the instrument from sample stream to supply of clean, oil free water. The instrument will switch over to alarm condition but will also continue to display the measurement result. The Electric Switchover Valve also allows remote flushing.



5.1 Specification OMD-24 EV

Range:	0 – 30 ppm, Trend indication 50 ppm
Accuracy:	According IMO MEPC. 107(49)
Linearity:	0 – 30 ppm better than $\pm 2 \%$
Display:	Yellow Graphic Display
Power Supply:	24 V AC or DC $\pm 10 \%$
Consumption:	< 15 VA
Alarm Points 1, 2:	Adjustable between 1 – 15 ppm* (Works adjustment 15 ppm)
Alarm 1 Operating Delay: (for annunciation purpose)	Adjustable between 1 – 540 sec. (Works adjustment 2 sec.)
Alarm 2 Operating Delay: (for control purposes)	Adjustable between 1 – 10 sec. (Works adjustment 10 sec.)
Alarm Indication: (Alarm 1, 2, System Fault)	Red LEDs
Alarm Contact Rating: (Alarm 1, 2, System Fault)	Potential free 1 pole change over contacts, 3 A / 240 V
Output Signal:	0 – 20 mA or 4 – 20 mA selectable, active current loop, ext. Load < 150 Ω
Sample/ Fresh Water Pressure:	0 – 6 bar recommended range of installation
Sample Flow:	Approx. 0.1 – 3 l/min
Sample Water Temperature:	+ 1 to + 65° C
Ambient Temperature:	+ 1 to + 55° C
Roll:	Up to 45°
Size: Computer Unit Measuring Cell	185 mm W x 210 mm H x 65 mm D 140 mm W x 160 mm H x 120 mm D
Distance (Computer Unit to Measuring Cell)	Up to 0.5 m Option: up to 5 m upon request
Weight:	2.5 kg
Degree of Protection:	IP 65
Pipe Connections:	R ¼" Female
→ Technical specifications are subject to change without notification.	

* By request the alarm set point can be set to 5 ppm max.



5.2 Construction OMD-24 EV

The OMD-24 EV consists of a Computer Unit, a Measuring Cell, which is equipped with an Electric Valve Assembly.

The Electric Valve controls sample water flow and clean water usage. The Electrical Valve can be controlled from the Computer Unit.

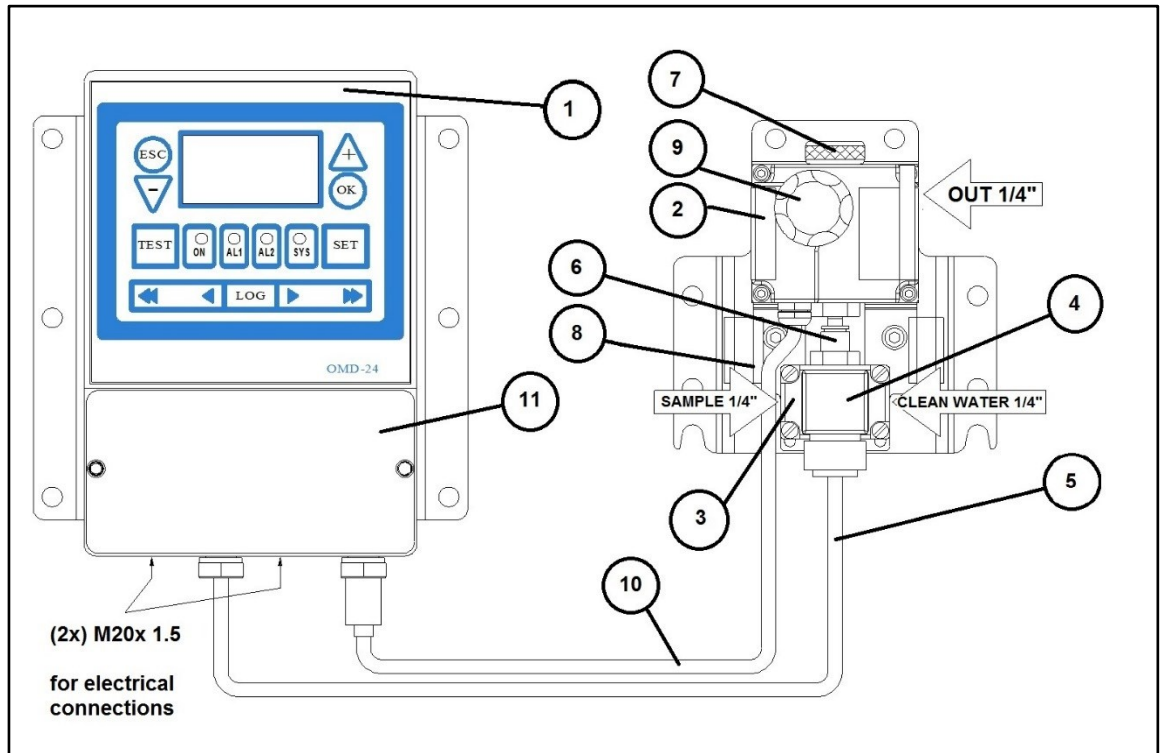

Figure 6. Construction OMD-24 EV

- | | | |
|--------------------|-------------------------|--------------------|
| 1. Computer Unit | 6. Push-In-Connector | 11. Terminal Cover |
| 2. Measuring Cell | 7. Cell Cap | |
| 3. Electric Valve | 8. Valve Support | |
| 4. Valve Connector | 9. Desiccator Cap | |
| 5. Valve Cable | 10. Communication Cable | |



DECKMA
HAMBURG

5.3 Installation OMD-24 EV

Please refer to the following drawing for mounting dimensions.

The Connector on top of the valve must not be removed under any circumstances, as that requires the breaking of the seal.

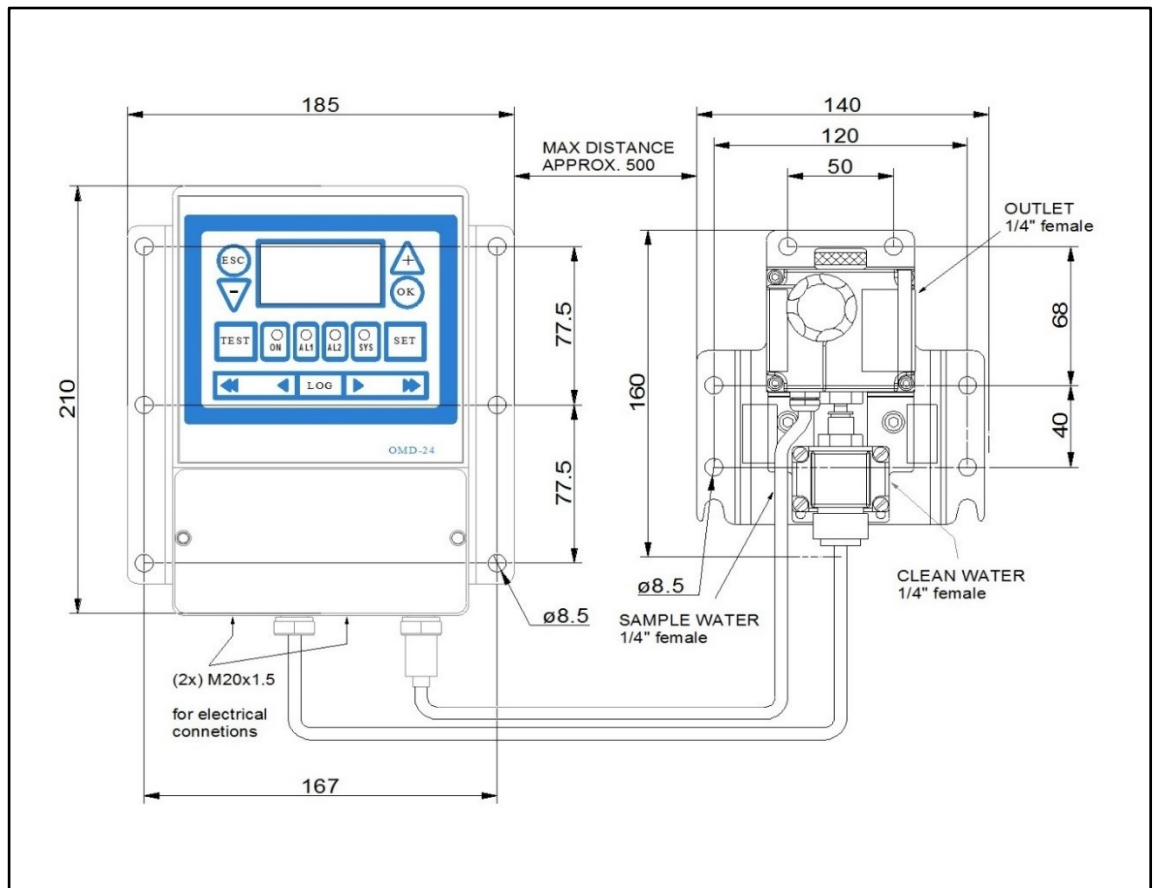

Figure 7. Installation OMD-24 EV



5.4 Piping OMD-24 EV

Connect the OMD-24 EV to the sample point of the oily-water separator outlet and to a source of oil free water employing 10 mm OD copper or stainless-steel pipe. The sample point should be located on a vertical section of the separator outflow piping to minimize the effects of any entrained air. The tapping point should be at a level above the outlet of the monitor to ensure the sample cell is flooded at all times.

If possible, it is recommended to install a manual valve into the clean water line next to the OMD-24 EV. This allows to stop any water flow through the instrument for easy manual cleaning. No additional valve in the sample line can be allowed.

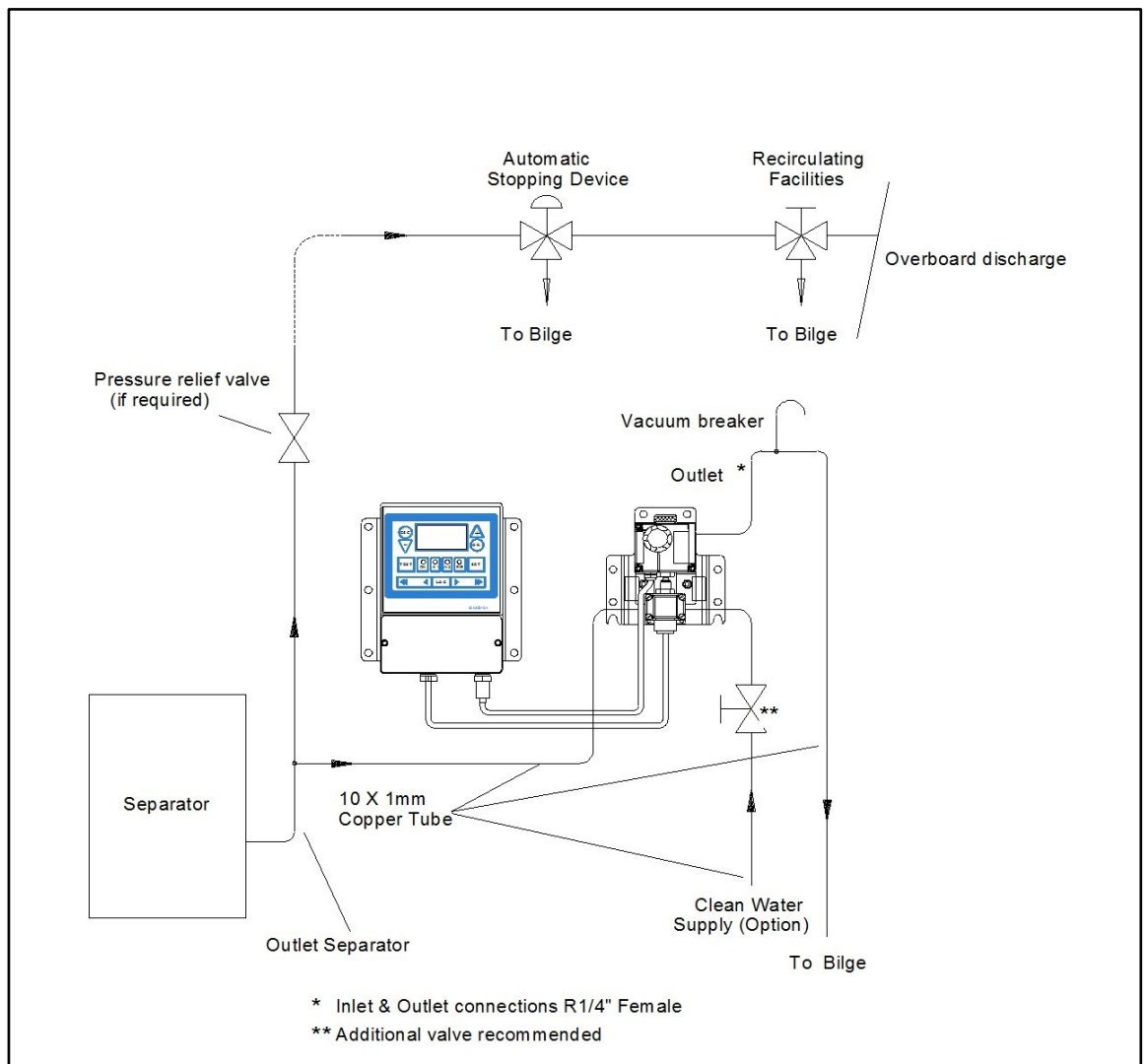

Figure 8. Piping OMD-24 EV



5.5 Cabling OMD-24 EV

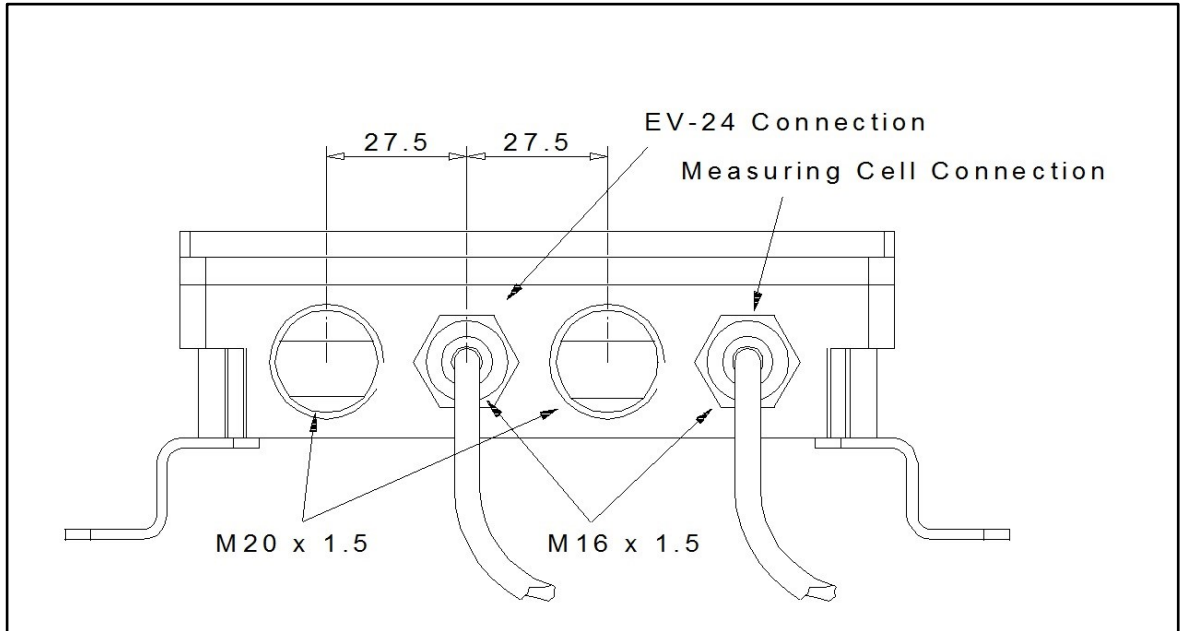

Figure 9. Bottom View: OMD-24 EV



DECKMA
HAMBURG

6. OMD-24 EVA

The OMD-24 EVA is fitted with an Electric Switchover Valve and an Automatic Cell Cleaning Device.



6.1 Specification OMD-24 EVA

Range:	0 – 30 ppm, Trend indication 50 ppm
Accuracy:	According IMO MEPC. 107(49)
Linearity:	0 – 30 ppm better than $\pm 2 \%$
Display:	Yellow Graphic Display
Power Supply:	24 V AC or DC $\pm 10 \%$
Consumption:	< 10 VA
Alarm Points 1 + 2:	Adjustable between 1 – 15 ppm* (Works adjustment 15 ppm)
Alarm 1 Operating Delay: (for annunciation purpose)	Adjustable between 1 – 540 sec. (Works adjustment 2 sec.)
Alarm 2 Operating Delay: (for control purposes)	Adjustable between 1 – 10 sec. (Works adjustment 10 sec.)
Alarm Indication: (Alarm 1, 2 System Fault)	Red LEDs
Alarm Contact Rating: (Alarm 1, 2, System Fault)	Potential free 1 pole change over contacts, 3 A / 240 V
Output Signal:	0 – 20 mA or 4 – 20 mA selectable, active, ext. Load < 150 Ω
Sample/ Fresh Water Pressure:	0 – 6 bar recommended range of installation
Sample Flow:	Approx. 2 l/min
Sample Water Temperature:	+ 1 to + 65° C
Ambient Temperature:	+ 1 to + 55° C
Roll:	Up to 45°
Size: (Computer Unit) (Automatic Cleaning Device) (Measuring Cell)	185 mm W x 210 mm H x 65 mm D 140 mm W x 240 mm H x 120 mm D 140 mm W x 280 mm H x 120 mm D
Weight:	2.5 Kg
Degree of Protection:	IP 65
Air Supply	4 – 6 bar
Air Pressure Regulator	Typical 4 bar
Pipe Connections: Air, Water	R ¼" Female
<p>→ Technical specifications are subject to change without notification. *By request the alarm set point can be set to 5 ppm max.</p>	



6.2 Construction OMD-24 EVA

The OMD-24 EVA consists of a Computer Unit, and a Measuring Cell, which is equipped with an EV-Valve and Automatic Cell Cleaning Device. Additionally, the components of the OMD-24 EVA are mounted onto three separate supports.

The Automatic Cell Cleaning Device is electrically inserted between the Computer Unit and the Measuring Cell. The cable length is limited to typical about 1 m. The cable is connected with the Measuring Cell as well as with the Automatic Cell Cleaning Device consecutively.

The Automatic Cell Cleaning Device additionally, needs a sufficient supply of dry clean instrument air.

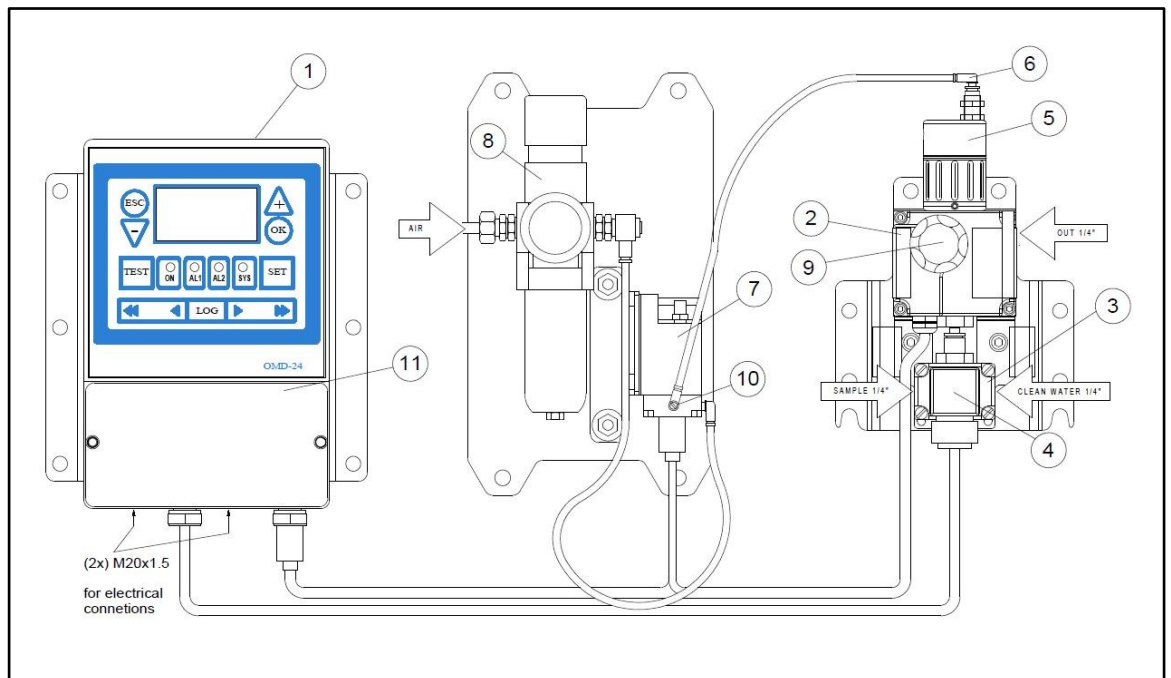

Figure 10. Construction OMD-24 EVA

- | | | |
|---------------------|------------------------------|--------------------|
| 1. Computer Unit | 6. Air Supply for Controller | 11. Terminal Cover |
| 2. Measuring Cell | 7. Autoclean Controller | |
| 3. Electrical Valve | 8. Air Regulator | |
| 4. Valve Connector | 9. Desiccator | |
| 5. Autoclean | 10. Air Flow Adjuster | |



6.3 Installation OMD-24 EVA

The OMD-24 EVA is fitted with the Auto Clean System. Installation of the OMD-24 EVA can be carried out in a few steps. Please notice on the figure below. The stated measurements for the drillings should be considered.

Install the Air Regulation Filter Unit close enough to the OMD-24 EVA for connection of the air pipe.

- Connect an air supply of 4 to 6 bar to the Air Regulation Filter Unit.
- Set the Air Regulation Unit output to a pressure of approximately 4 bar typical. Too high-pressure settings can cause unnecessary wear. Low pressure may make operation unreliable.
- Insert the wiper into the cleaner. Check the Wiper Seal for damage.
- Put Auto Clean system onto Measuring Cell. Make sure it is completely screwed in. If it is only partially screwed in, flow rate regulation will not work and may cause unstable operating conditions for the instrument.
- Connect air hose to Automatic Cell Cleaning Device.

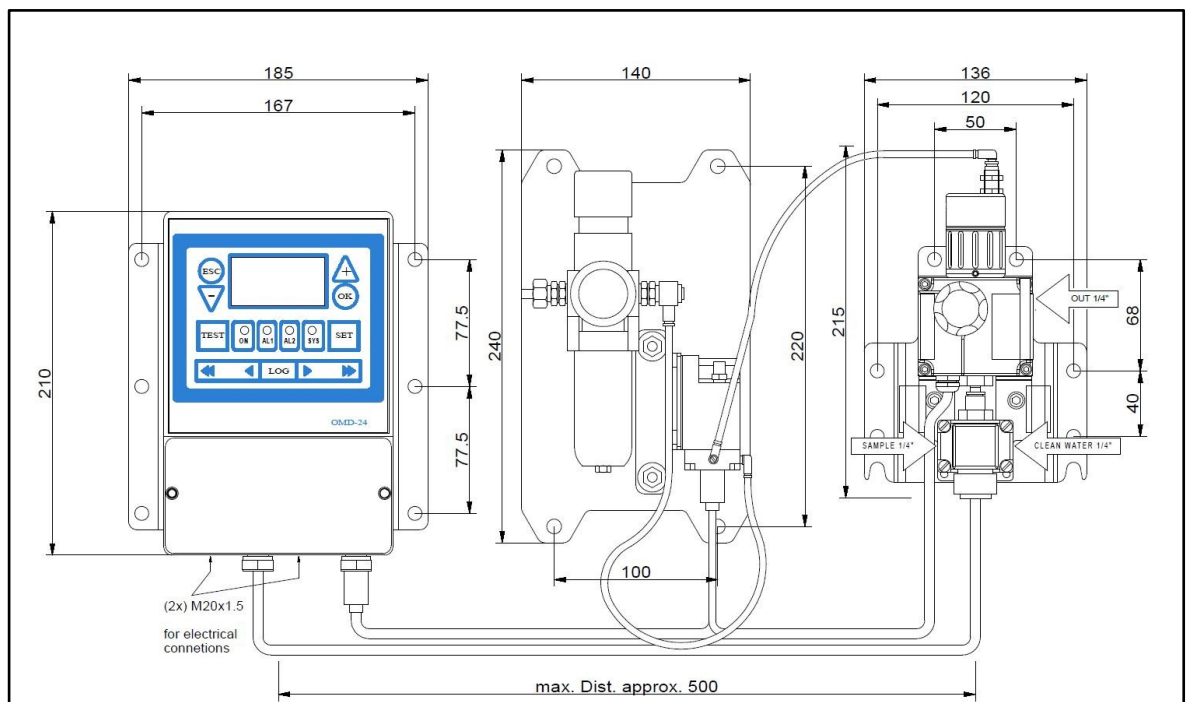

Figure 11. Installation OMD-24 EVA



6.4 Piping OMD-24 EVA

Connect the Sample line to the left side input of the OMD-24 EVA. Connect the clean water line to the right-hand side input of the valve. Both inputs have 1/4" female threads. It is recommended to employ 6 mm, 10 mm copper or stainless-steel pipe. If it is possible, install a manual valve into the clean water line next to the OMD-24 EVA. For Air Regulation connect the air pipe to the Unit and the Measuring Cell. The air supply should be of 4 to 6 bar.

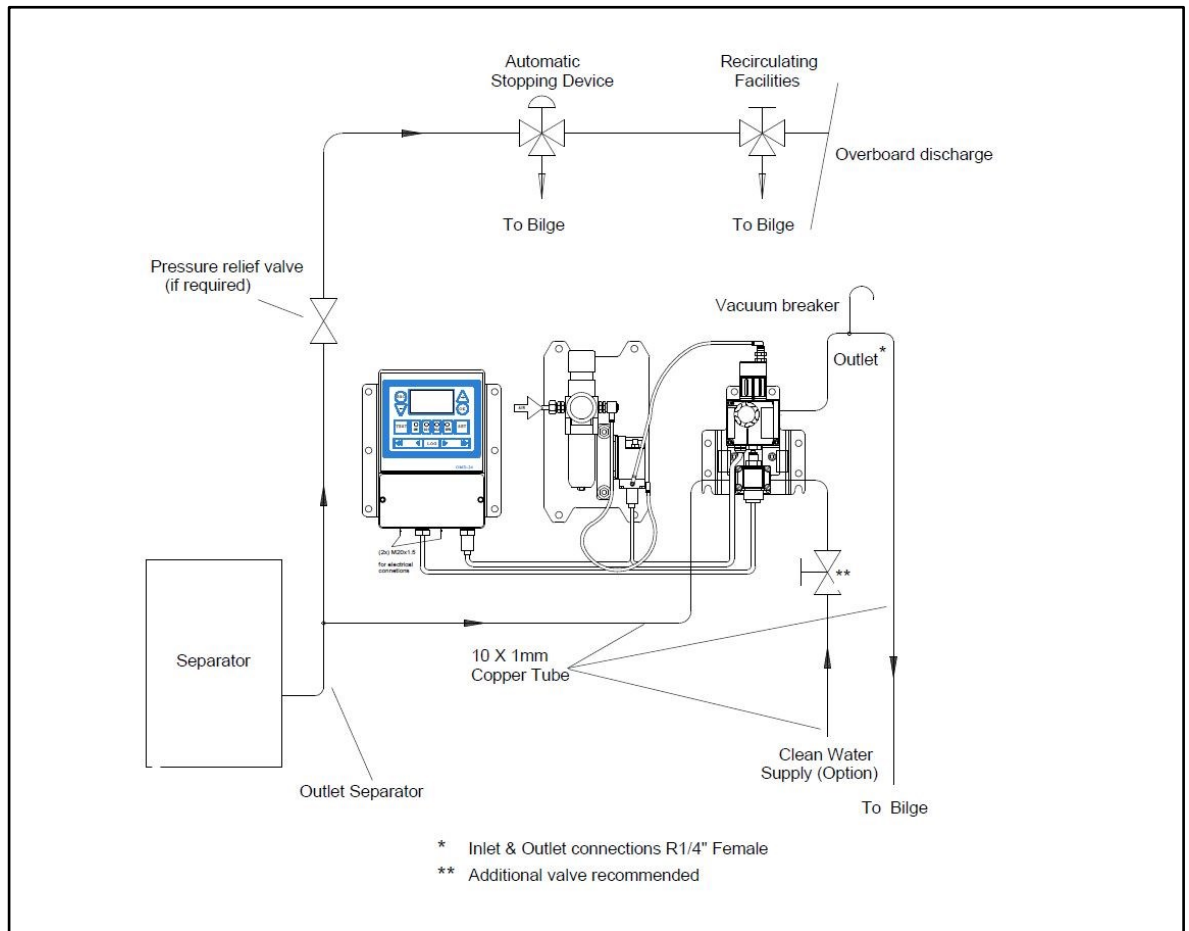

Figure 12. Piping OMD-24 EVA



6.5 Cabling OMD-24 EVA

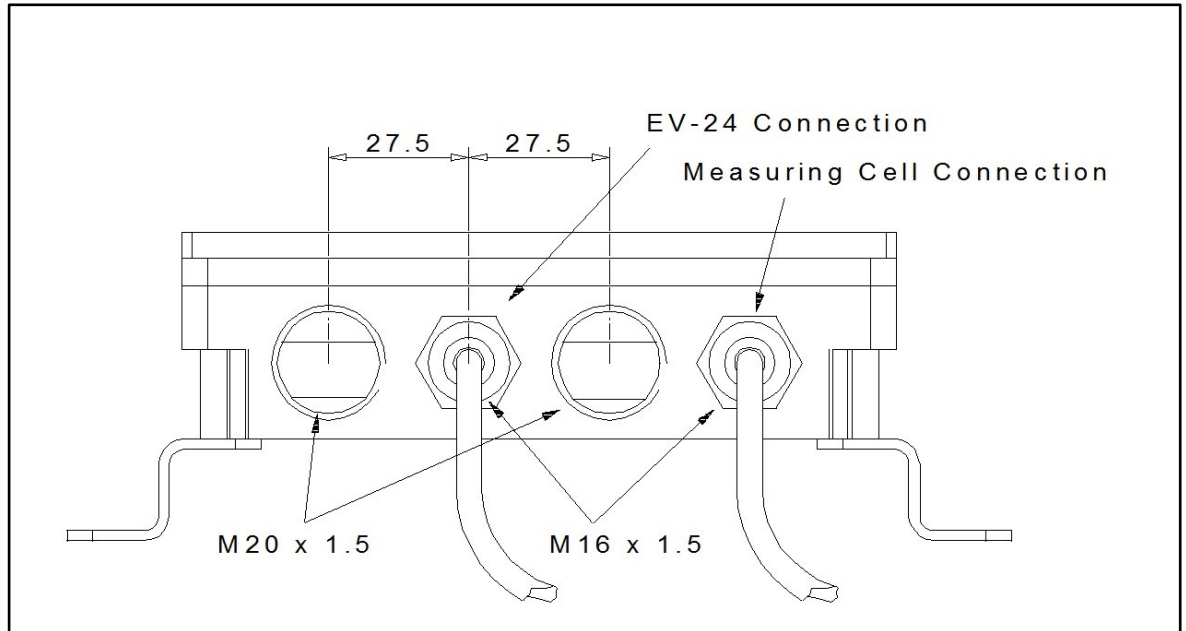

Figure 13. Bottom View: OMD-24 EVA

The OMD-24 EVA is in tandem with the Automatic Cell Cleaning Device. The Automatic Cell Cleaning Device is connected with the Measuring Cell with another cable.



DECKMA
HAMBURG

7. OMD-24 A

The OMD-24 A is prepared with an Automatic Cell Cleaning Device for Auto Clean operation.



7.1 Specification OMD-24 A

Range:	0 – 30 ppm, Trend indication 50 ppm
Accuracy:	According IMO MEPC. 107(49)
Linearity:	0 – 30 ppm better than $\pm 2 \%$
Display:	Yellow Graphic Display
Power Supply:	24 V AC or DC $\pm 10 \%$
Consumption:	< 10 VA
Alarm Points 1 + 2:	Adjustable between 1 – 15 ppm* (Works adjustment 15 ppm)
Alarm 1 Operating Delay: (for annunciation purpose)	Adjustable between 1 – 540 sec. (Works adjustment 2 sec.)
Alarm 2 Operating Delay: (for control purposes)	Adjustable between 1 – 10 sec. (Works adjustment 10 sec.)
Alarm Indication: (Alarm 1, 2 System Fault)	Red LEDs
Alarm Contact Rating: (Alarm 1, 2, System Fault)	Potential free 1 pole change over contacts, 3 A / 240 V
Output Signal:	0 – 20 mA or 4 – 20 mA selectable, active, ext. Load < 150 Ω
Sample/ Fresh Water Pressure:	0 – 6 bar recommended range of installation
Sample Flow:	Approx. 2 l/min
Flow Meter: Measuring Range:	Vortex Type: 0.7 – 4.5 l/min
Sample Water Temperature:	+ 1 to + 65° C
Ambient Temperature:	+ 1 to + 55° C
Roll:	Up to 45°
Size: (Computer Unit) (EV-FC-Arrangement)	185 mm W x 210 mm H x 65 mm D 150 mm W x 290 mm H X 140 mm D
Weight:	2.5 kg
Degree of Protection:	IP 65
Pipe Connections:	For 6 mm OD Cu or SS Pipe
→ Technical specifications are subject to change without notification.	
*By request the alarm set point can be set to 5 ppm max.	



7.2 Construction OMD-24 A

OMD-24 A consists of a Computer Unit, and a Measuring Cell, and a further air supply regulator component.

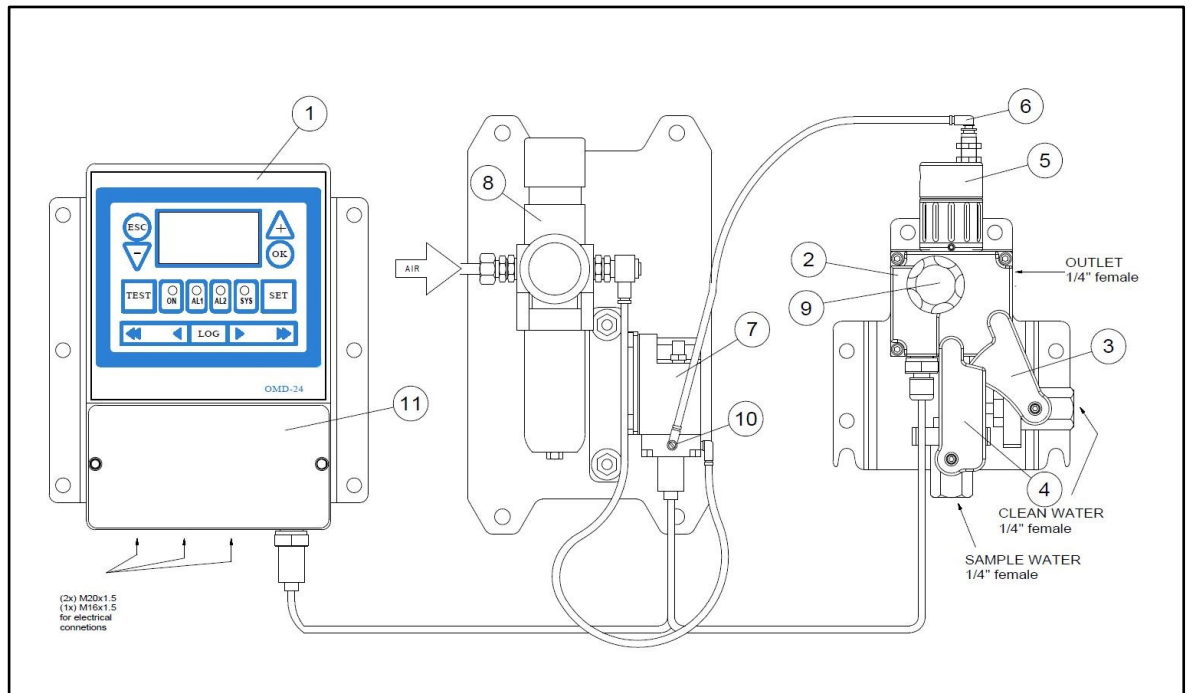

Figure 14. Construction OMD-24 A

- | | | |
|-----------------------|------------------------------|-------------------------|
| 1. Computer Unit | 4. Sample Water Handle | 7. Autoclean Controller |
| 2. Measuring Cell | 5. Autoclean | 8. Air Regulator |
| 3. Clean Water Handle | 6. Air Supply for Controller | 9. Desiccator Cap |
| 10. Air Flow Adjuster | 11. Terminal Cover | |



7.3 Installation OMD-24 A

Computer Unit and Measuring Cell assembly should be mounted close to each other. Please refer to the following drawing for mounting dimensions.

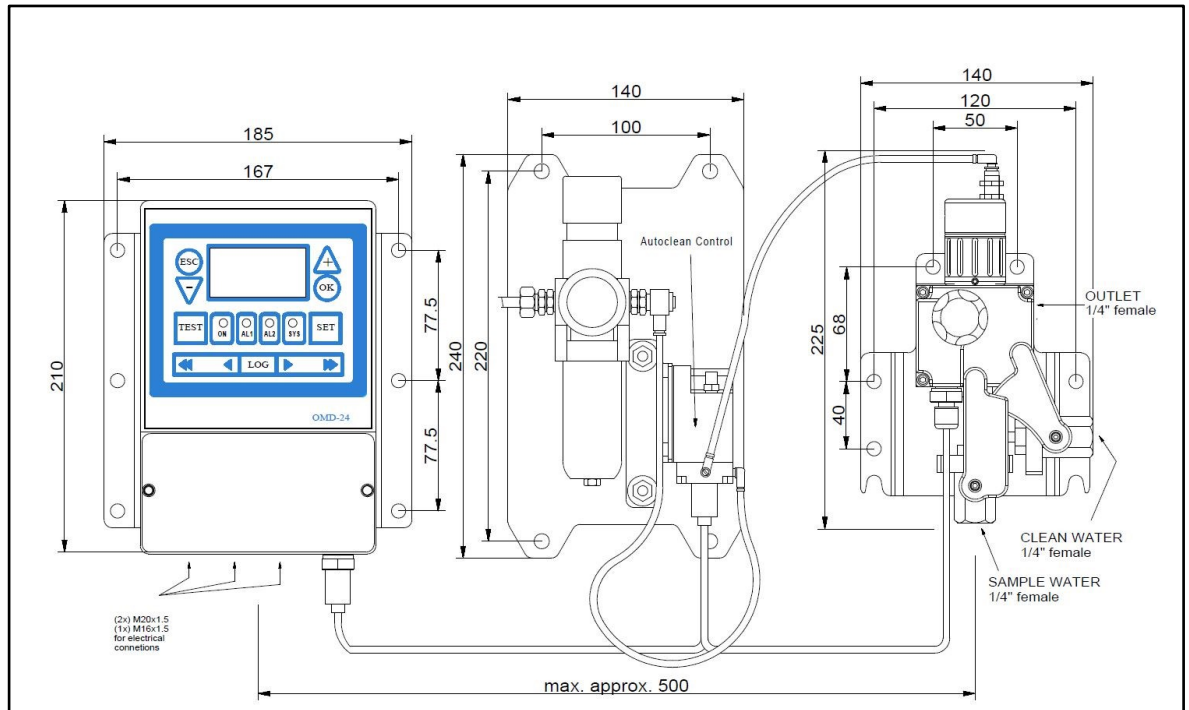

Figure 15. Installation OMD-24 A

Pipe connections are prepared for 6 mm OD stainless steel or copper pipes. Adapter fittings for other pipe diameters are available upon request. Working space for maintenance and operation is recommended in front of and above the instrument.



7.4 Piping OMD-24 A

Connect the OMD-24 A Monitor to the sample point of the oily-water separator outlet and to a source of oil free water. Fittings on the instrument are for 6 mm, 10 mm OD copper or stainless-steel pipe. Adapter fittings for other pipe diameters are available upon request.

The sample point should be located on a vertical section of the separator outflow piping to minimize the effects of any entrained air. The tapping point should be at a level above the outlet of the monitor to ensure the sample cell is flooded at all times.

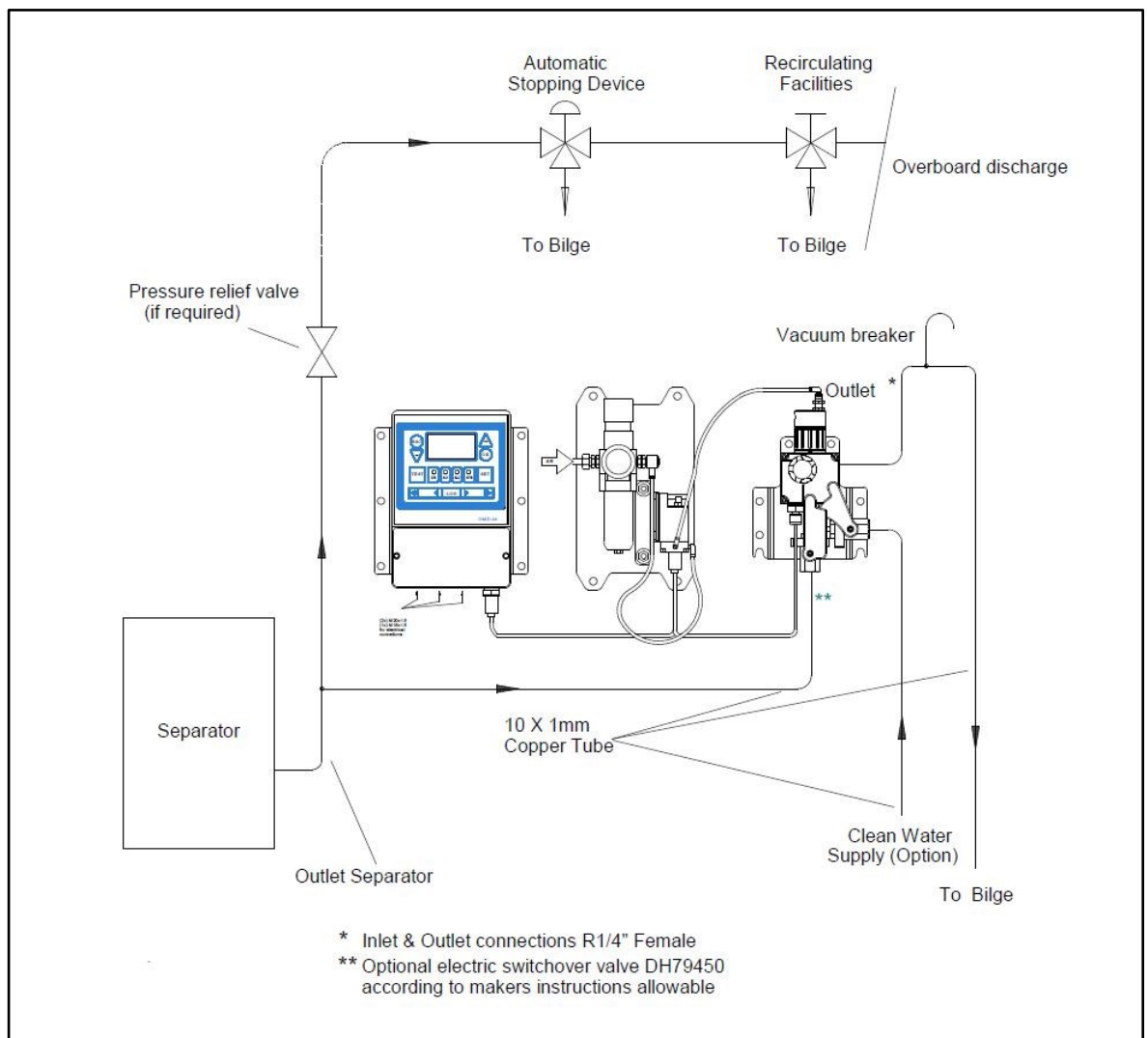

Figure 16 Piping OMD-24 A



7.5 Cabling OMD-24 A

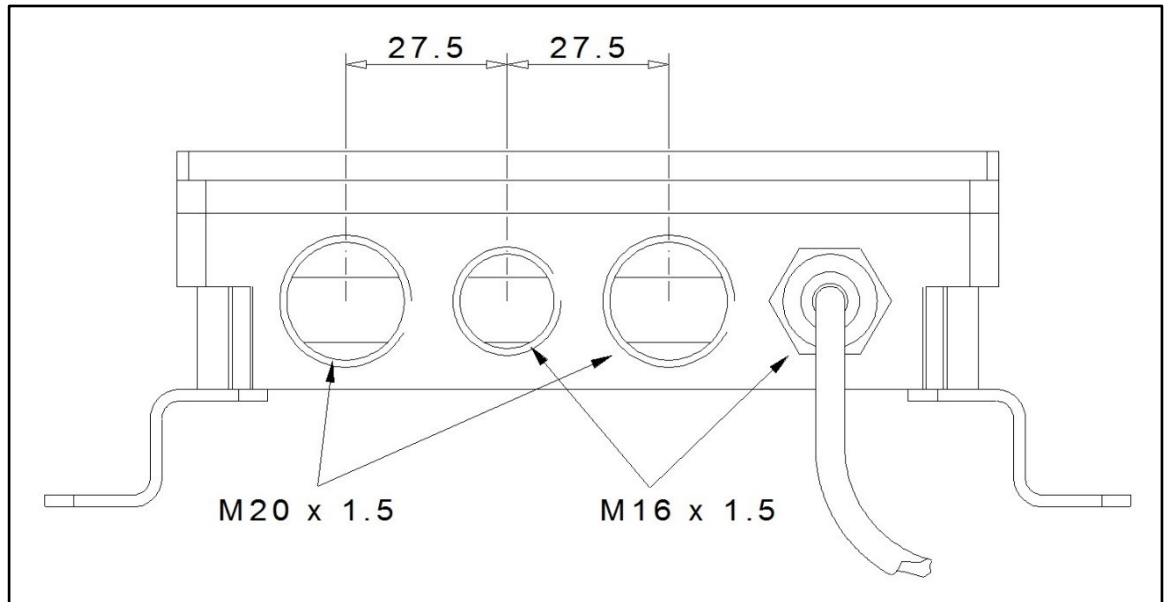

Figure 17. Bottom View: OMD-24 A

The OMD-24 A is connected with a y-cable to the Measuring Cell and the Flow Sensor.



DECKMA
HAMBURG

8. OMD-24 FC (Conversion-Kit)

The Conversion-Kit to OMD-24 FC has been designed specifically for use in conjunction with 15 ppm oil-water separator units, which have a specification and performance which exceeds the requirements of the International Maritime Organization IMO specification for 15 ppm Bilge Alarms contained in Resolution MEPC.107 (49).

The Conversion-Kit can only be used in conjunction with an OMD-24 Computer Unit.

The Flow Sensor monitors the sample flow rate through the Measuring Cell.



8.1 Specification OMD-24 FC (Conversion-Kit)

Range:	0 – 30 ppm, Trend indication 50 ppm
Accuracy:	According IMO MEPC. 107(49)
Linearity:	0 – 30 ppm better than $\pm 2\%$
Display:	Yellow Graphic Display
Power Supply:	24 V AC or DC $\pm 10\%$ Automatic Voltage selection
Consumption:	< 10 VA
Alarm Points 1 + 2:	Adjustable between 1 – 15 ppm* (Works adjustment 15 ppm)
Alarm 1 Operating Delay: (for annunciation purpose)	Adjustable between 1 – 540 sec. (Works adjustment 2 sec.)
Alarm 2 Operating Delay: (for control purposes)	Adjustable between 1 – 10 sec. (Works adjustment 10 sec.)
Alarm Indication: (Alarm 1, 2 System Fault)	Red LEDs
Alarm Contact Rating: (Alarm 1, 2, System Fault)	Potential free 1 pole change over contacts, 3 A / 240 V
Output Signal:	0 – 20 mA or 4 – 20 mA selectable, active, ext. Load < 150 Ω
Sample/ Fresh Water Pressure:	0 – 6 bar
Recommended Sample Flow:	Approx. 2 l/min
Flow Meter: Measuring Range:	Vortex Type: 0.50 – 4,5 l/min Low Flow Alarm 0.7 l/min (factory set)
Sample Water Temperature:	+ 1 to + 65° C
Ambient Temperature:	+ 1 to + 55° C
Roll:	Up to 45°
Size: (Computer Unit) (Automatic Cleaning Device) (Measuring Cell)	185 mm W x 210 mm H x 65 mm D 140 mm W x 240 mm H x 120 mm D 140 mm W x 280 mm H x 120 mm D
Weight:	1 Kg
Degree of Protection:	IP 65
Air Supply (optional)	4 – 6 bar
Air Pressure Regulator (optional)	Typical 4 bar
Pipe Connections: Air, Water (optional)	R ¼" Female
→ Technical specifications are subject to change without notification.	



8.2 Construction

The sample stream from the drain connection of the OMD-24 measuring cell is connected to the Deckma Hamburg Flow Sensor. A Sensor PCB has to be installed into the terminal compartment of the Computer Unit. The Sensor-PCB is connected to the Flow Sensor and the Measuring Cell by an 8pin connector and Y-Cable.

To achieve laminar flow to the Flow Sensor, a straight pipe of 100mm length must be installed at the inlet side of the Flow Sensor. The Conversion-Kit contains a suitable 6mm OD pipe with fittings for direct connection to the OMD-24 Measuring Cell.

i

Please note: The flow laminator pipe should not be bent.

The Conversion-Kit to OMD-24 FC is shown in solid dark red lines below. In addition, the individual components of the Connection-Kit are indexed.

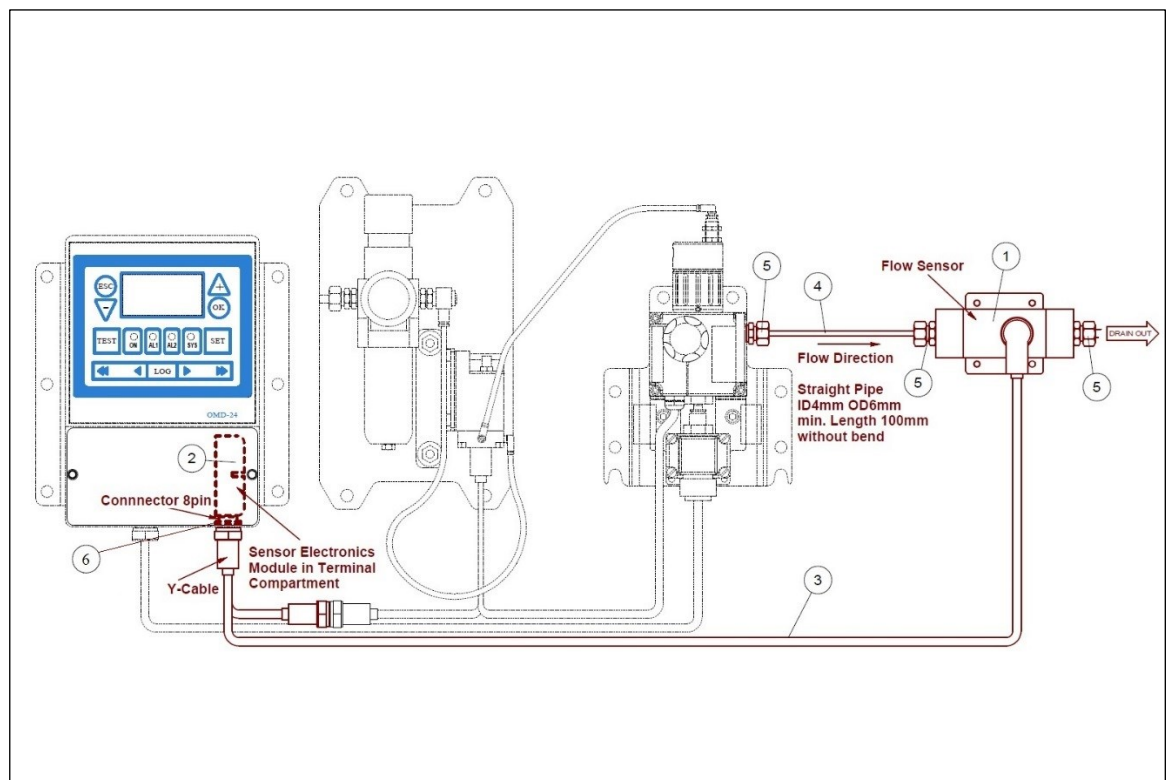

Figure 18 OMD-24 FC

1. Flow Sensor
2. Sensor PCB
3. Y-Cable
4. Flow Laminator Pipe
5. Fitting 1/4" 6mm
6. Connector 8 pin





8.3 Installation



The Conversion-Kit to OMD-24 FC should be located as shown in section 8.2 Construction. The Vortex Flow Sensor can be installed in two different ways. It is recommended to use either Option 1. or Option 2.

8.3.1 Electrical Installation Step-By-Step

→ See Section 2. Important Notes concerning installation.

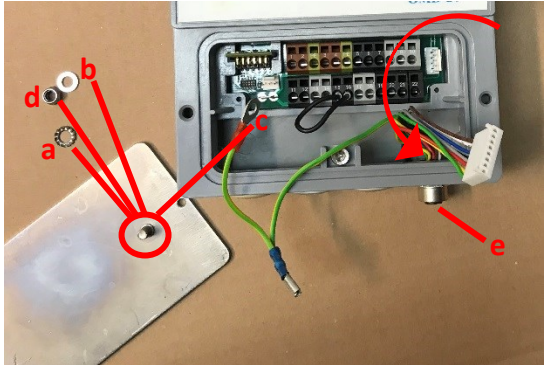
<p>STEP 1.</p> <p>Unscrew the terminal cover.</p>	
<p>STEP 2.</p> <ol style="list-style-type: none">Unscrew the PE-Cable from the terminal cover.Remove the connection cable from the PCB.Unscrew in countered the connection cable from computer box.	
<p>STEP 3.</p> <ol style="list-style-type: none">Put the spring washer onto the screw of the terminal cover.Put the ring washer onto the screw of the terminal cover.Put the PE-Cable onto the screw of the terminal cover.Tight in the nut.Insert the Y-Cable through the terminal compartment und screw it.	



STEP 4.

Connect the PE-Cable to the Computer Unit.

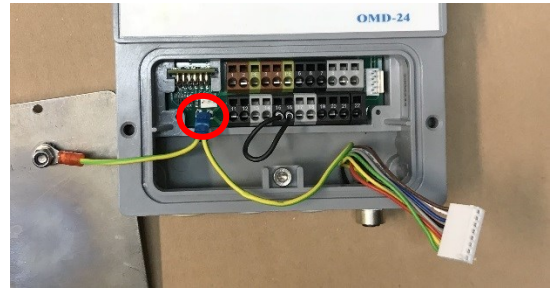

STEP 5.

Install carefully the 8-pin connector to the Sensor-PCB.

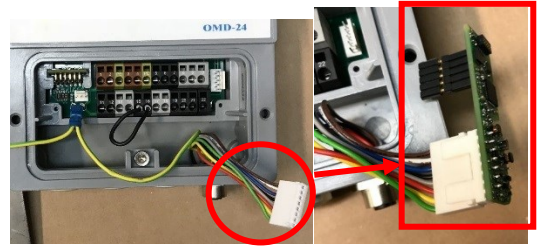

STEP 6.

Connect the Sensor-PCB to the 5-Pin-Connector of the Computer Unit.

i

Do not use excessive force to mount the Sensor-PCB.

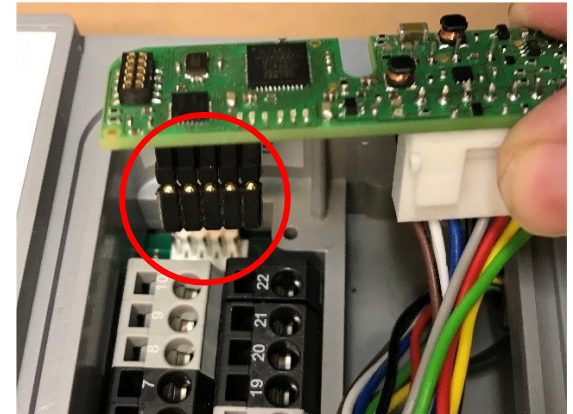

STEP 7.

Position the Sensor-PCB into the terminal compartment and make Sure, that the Connector-Cable is not underneath the Sensor-PCB

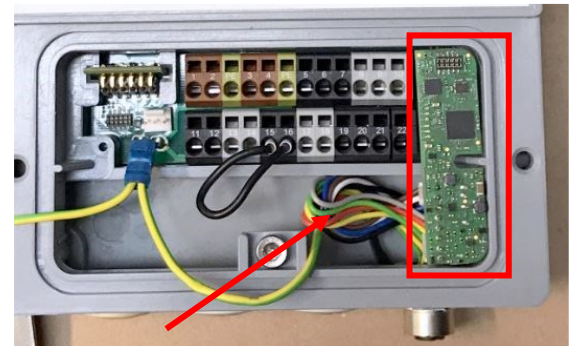

STEP 8.

Make sure, that the PCB protection is mounted onto the Sensor-PCB.

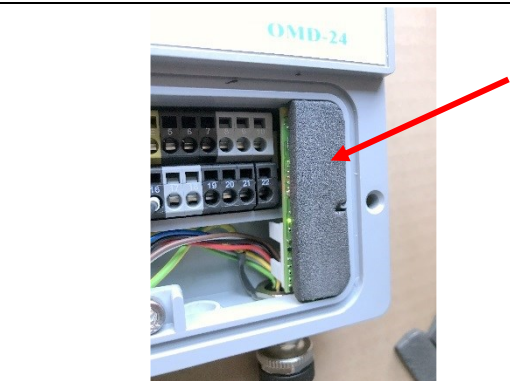



STEP 9.

Tighten the terminal cover.



Step 10.

- a) Connect the Y-Cable to the Measuring.
- b) Cell and to the Vortex Flow Meter.

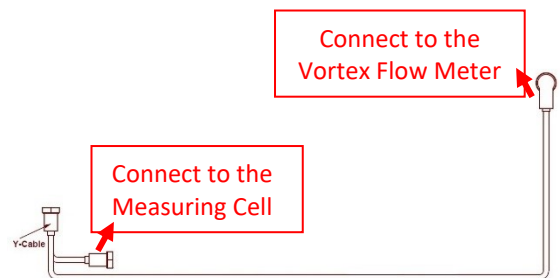

8.3.2 Typical Piping Installation

Option 1.

The flow direction is from left to right. For the piping, remove the previous fittings and mount the delivered fittings 1/4" 6 mm OD.

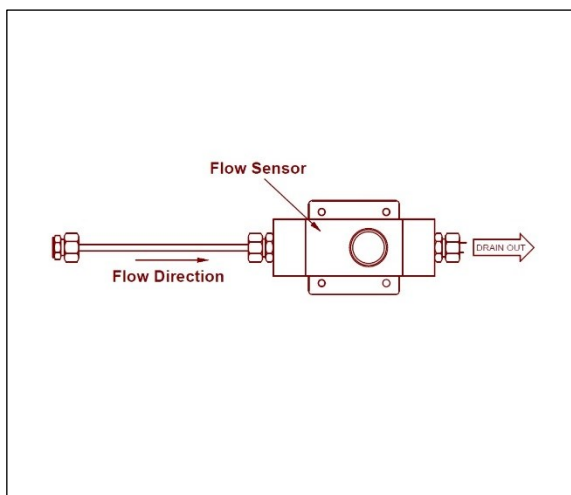

Option 2.

The flow direction is bottom-up. Make sure that the flow laminator pipe should not be bent about 100mm to the Flow Sensor.



The bent flow laminator pipe is not delivered by DECKMA HAMBURG.

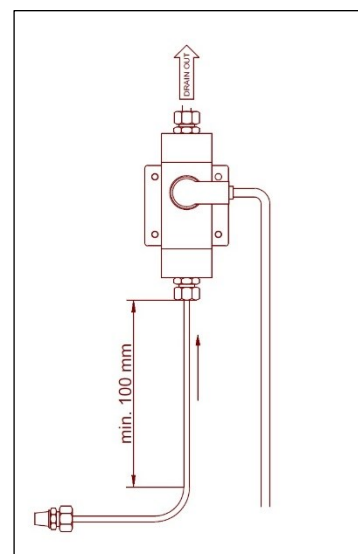



8.4 FC Principle of operation

8.4.1 FC (Flow Control)

OMD-24 FC are equipped with a Vortex Flow Sensor (For technical information see Appendix II). The Sensor-PCB displays flow status via several LEDs for commissioning purposes. A flow rate between 0.7 l/min to 4.5 l/min can be measured. If the flow rate through the Measuring Cell is below 0.7 l/min for more than 4 seconds, or if the sample is not flowing at all, the Instrument will go to Alarm condition and issue a **“Status: Flow!”** message. If a flow rate of more than 0.7 l/min is achieved, the unit will be out of alarm.

8.4.2 Description of Sensor-PCB LEDs

Green	Flow > 2.0 l/min	←
Green	Flow > 1.5 l/min	←
Green	Flow > 1.0 l/min	←
Yellow	Flow > 0.7 l/min	←
RED	Flow Meter ON	←
RED	Flow OFF	←

Green	Sensor PCB Power Supply OK	←
Green	Vortex Flow Meter Power Supply OK	←

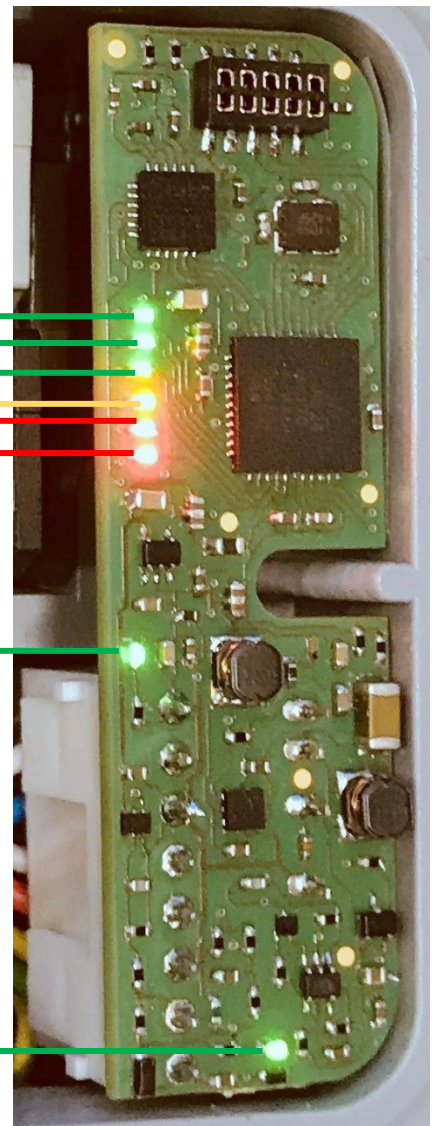



9. Cleaning Devices

Optional item, if fitted.

There are two optional Cleaning Units available. Both allow routine cleaning of the Sample Glass Tube. They are different in the way they are operated.

9.1 Manual Cleaning Unit (MCU)/ Automatic Cell Cleaning Device

The Automatic Cell Cleaning Device is driven pneumatically, while the Manual Cell Cleaning Unit has to be operated by hand. The cleaning mechanism is identical: a wiper moves through the Sample Glass Tube and removes deposits from the Sample Glass Tube surface. This unit facilitates cleaning of the cell without the need of removing the Cell Cap. Regular use of this device can reduce difficulties in operation of the monitor due simply avoiding of the Sample Glass Tube and all the inconvenience this can cause.

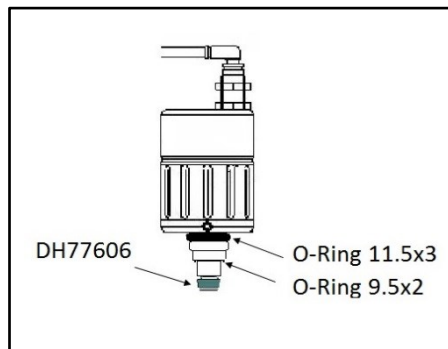

Figure 19. Automatic Cell Cleaning Device, pneumatically operated

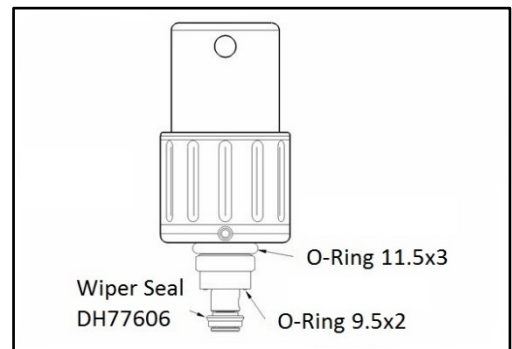

Figure 20. MCU DH77780 Manual Cell Cleaning Unit, manually operated

9.1.1 Flow rate regulation on MCU, Auto Clean System

Flow rate is regulated by using a small O-Ring inside the cleaning device. There is a groove for an O-Ring.

(For more information, see section 12.3 *Flow*).



10. Terminals description

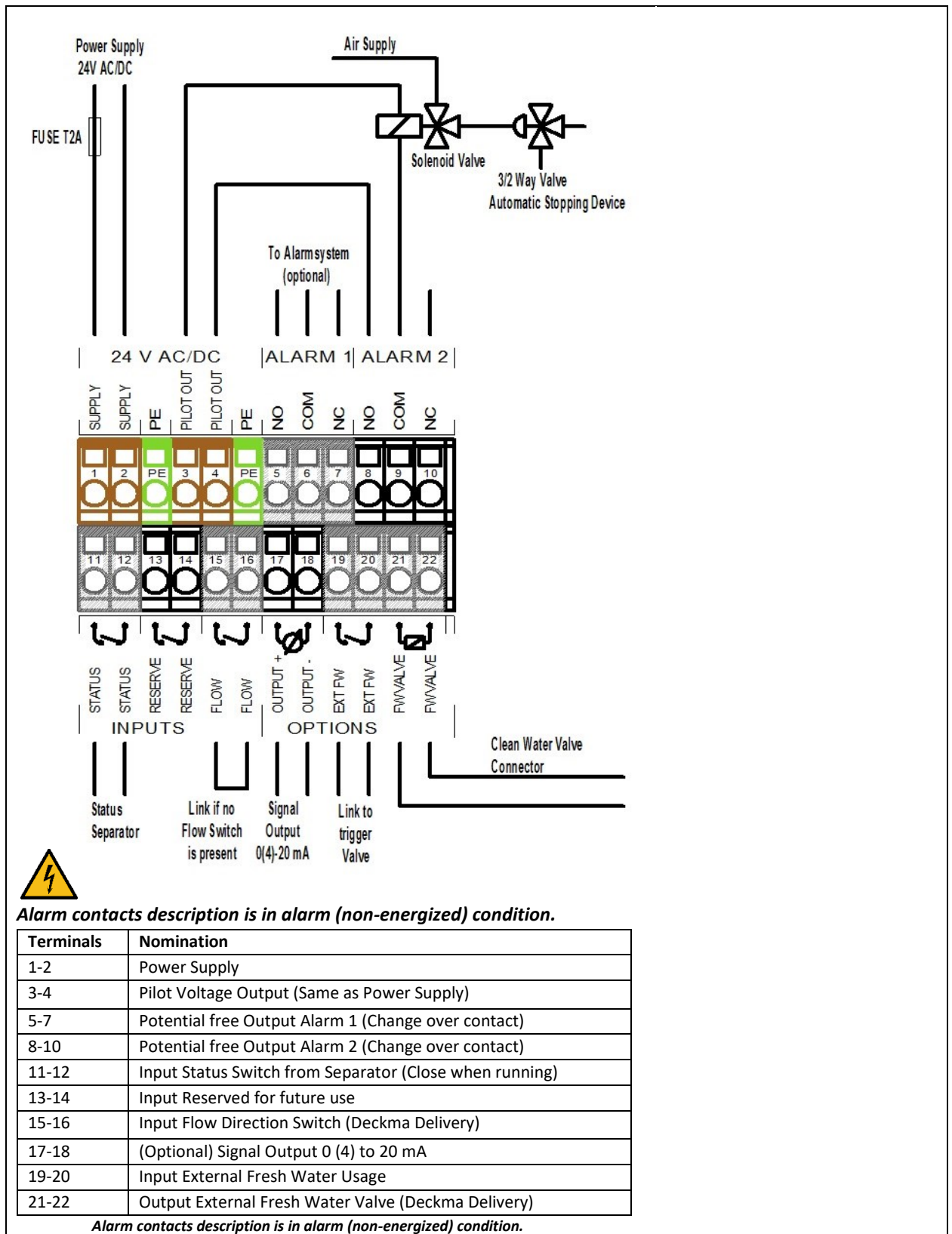

Figure 21. Connection Example



DECKMA

HAMBURG

Precise wiring details will vary dependent upon the control system to be employed but the most frequently used systems employ alarm relay 1 for alarm only and alarm relay 2 for overboard valve purposes.

Electrical connections are made to the terminal blocks inside the computer housing. Wires are connected to the terminals by pushing a suitable screwdriver into the clamp holes to release the internal spring-loaded clamps. After the wire is inserted to the terminal and the screwdriver is removed, the wire is fixed.

Terminals 1&2 are reserved for power supply input. Up next is the first ground connection PE.

The instrument provides a pilot voltage output at Terminals 3&4. This is internally connected to the power supply input (Terminals 1&2 via Fuse T2A). The pilot voltage can be used to supply additional external circuitry, e.g. alarm lamps or electrical valves. Up next is the second Ground (PE), which is connected to the Ground (PE).

i

Please note: any device connected to the pilot voltage output must be rated for the voltage the instrument is supplied with. Do not use the pilot voltage for driving motors, heaters or other high load devices. The pilot voltage is intended for alarm purposes only.

The Terminals 5 – 10 are staffed for alarm 1&2. The switch over contact relays are reserved for alarm 1 and alarm 2, respectively. These are free switch over contacts. **NO** means “**Normally Open**”, **COM** means “**Common**”, and **NC** is “**Normally Close**”. The Terminals 5 – 7 are changeover contacts for the potential free output alarm 1. Terminal 5 is NO, Terminal 6 is COM, and Terminal 7 is NC. The Terminals 8 – 10 are also changeover contacts for the potential free output alarm 2. Terminal 8 is NO, Terminal 9 is COM, and Terminal 10 is NC (see Figure 21. Connection Example).

The Terminals 11&12 are dedicated “STATUS” inputs for the STATUS SEPERATOR signal provided by the separator.

i

Note: In case the OMD-24 Series are installed*, a link across terminal 11 + 12 can be installed. Alternatively, a “Status Separator” signal can be generated from the Separator control, and an auxiliary relay be operated with this signal. The Contacts of this relay then can operate the “STATUS” input. Please refer to the Separator manual, or contact the separator maker for information regarding the separator. Additionally, the separator status will be recorded into the data logger.

Input “RES” is reserved for future use. The state of the “RES” input is recorded in the electronic record.

Terminals 15&16 are input for an optional external flow switch. Use a dry contact. The Unit is delivered with a link as standard. If the Terminals are open, the Unit will be in alarm condition.

*As replacement to a MEPC.60(33) approved separator and no “Status Separator” signal is available.



DECKMA
HAMBURG

Terminals 17&18 are for signal output of 0(4) to 20 mA. These are active outputs with an open-load voltage about 5 V. And it is recommended not to exceed the 150 Ω external load. The signal output complies the oil content from 0 to 30 ppm. In case of malfunction e.g. EE means 20 mA.

The Terminals 19&20 could be linked to switch the EV-Valve to clean water. The EV-Valve allows to remotely control the valve operation. The EV-Valve will stay in clean water condition, and the OMD-24 will remain in alarm condition, as long as the link (Terminals 19&20) is present. These are dry contacts as well.

The Terminals 21&22 are outputs for external fresh water usage feedback. The OMD-24 EV, EVA, A will close the FW Valve Feedback contact whenever the FW Valve is set to clean water usage.

Note: The Feedback contact is not influenced from the system fault conditions.

i

Note: For any input, it has to be used a potential free relay switch for the link to electrically insulate the OMD-24 from any external voltages.

Generally, the inputs and the output share a common potential (Terminals: 12, 14, 16, 18, 20, 22).

10.1 External Control System

The installation on site has to make sure that in case of any loss of power supply and/or loss of air supply for the automatic stopping device the overboard discharge valve close the overboard line and open the re-circulating line.

The system showed in the example see Figure 21. Connection Example, employs alarm relay 2 to control a pneumatic solenoid valve which energizes or de-energizes a pneumatically operated 3 - way valve.

The separation process will continue until such time as the pollution level falls below the alarm set point at which time the discharge will be directed overboard.

A pump stop system is according MEPC.107(49) not allowed.



DECKMA
HAMBURG

11. Power Supply

→ (See Section 2. *Important Notes*).



The unit is designed for a power supply of 24 V AC or DC. The power supply must have a fuse rated no more than T2A.

Power consumption of the OMD-24 EV is increased by approx. 10 VA to about 15 VA while the Clean Water Valve is energized (clean water flushing).



12. Commissioning

For operating and servicing on board, please carefully read the instruction manual and ensure, that the safety recommendations are considered. Read important notice as well. Ensure that wires are correctly connected to the terminal blocks inside the computer housing and ensure that the connection to the Measuring Cell is in place (refer to Figure 2. Construction OMD-2 to Figure 14. Construction OMD-24 , respectively). On completion of the installation, cabling, and piping, carry out the following checks:

12.1 Electrical and Piping



- a) Check that the power supply is connected to the terminals 1&2 of the terminal block.
- b) Check that the grounding (PE) has been made. Refer to the relevant regulations.
- c) Check that the cabling of the automatic stopping device (Back-to-bilge-valve) and to the alarm system is according the IMO Requirements.
- d) Check all piping connections for leaks and rectify as appropriate.
- e) Check the sample supply and the fresh water supply.
- f) Check that the Clean Water Valve is connected to the terminals 21&22 of the terminal block and the connector is seated firmly on the valve.
- g) Check that the remote trigger cabling (if any) is connected to terminals 19&20 of the terminal block.

For instruments equipped with a Conversion-Kit, check the following point.

- h) Check that the Sensor-PCB is installed correctly and is supplied with voltage.

Automatic or manual Cell Cleaning Unit, check the following points:

For instruments equipped with an Automatic or manual Cell Cleaning Unit, check the following points:

- i) Check, that the Cell Cleaning Device is fitted correctly.
- j) Check, that the push in connectors and hoses are fitted correctly (Automatic Cleaning system only).
- k) Check that the Air Supply is between 4 – 6 bar.



During the installation of the unit it is recommended to wear safety boots, due to weight.



DECKMA
HAMBURG

12.2 Instrument Start-Up Sequence

Switch on:

- a) Power Supply (24V)
- b) Sample Flow
- c) FW Flow
- d) Air Supply 4 - 6 bar (Automatic Cell Cleaning Device)

Make sure, that the Power LED is illuminated and the display is showing the initializing display for about 15 sec. After that time, it will change to the “normal operation” display, showing the actual measurement as shown below in *Figure 22. “Initializing Display”* and *Figure 23. “Normal Operation” Display*.



Figure 22. “Initializing Display”

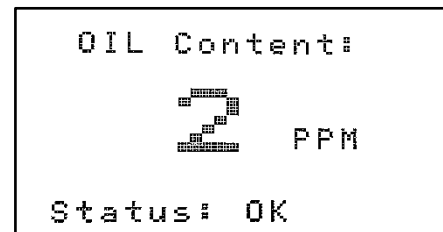

Figure 23. “Normal Operation” Display

Allow a period of time for water entering the Sample Glass Tube. It is recommended to let oil free water flow for about 10 minutes. Switch the EV, the manual valve, respectively, to clean water stream. Check, that the display shows 0 to 2 ppm. If not, see 14.3

Cleaning Process. Check the relative desiccator humidity. Switch the instrument back to sample stream flow to the separator sampling point connection.

12.3 Flow rate Adjustment

The flow rate is not influencing the accuracy of the instrument as required by IMO. The adjustment is only important for the time delay between the sample point and the monitor. The flow rate can be adjusted to compensate environmental changes and pump aging, e.g.

If the installation has a clean water feed, the flow rate should be checked on both, the clean water supply and the sample supply. If the clean water supply is obtained from a high-pressure source, the flow rate will be higher than from the sample point.

Measure the amount of water flowing through the instrument. Flow rate should be approximately 2 liters per minute.



DECKMA

HAMBURG

Flow rate adjustments can be made by Cell Cap, MCU or the Automatic Cell Cleaning Device.

Adjust the flow rate through the unit by using the O-Rings in the normal Cell Cap.

- Low Flow:** Let all three O-Rings inside the cap.
Medium Flow: Take out the inside O-Ring 4.5x2.
High Flow: Let the Main O-Ring 11.5x3 as figured below.

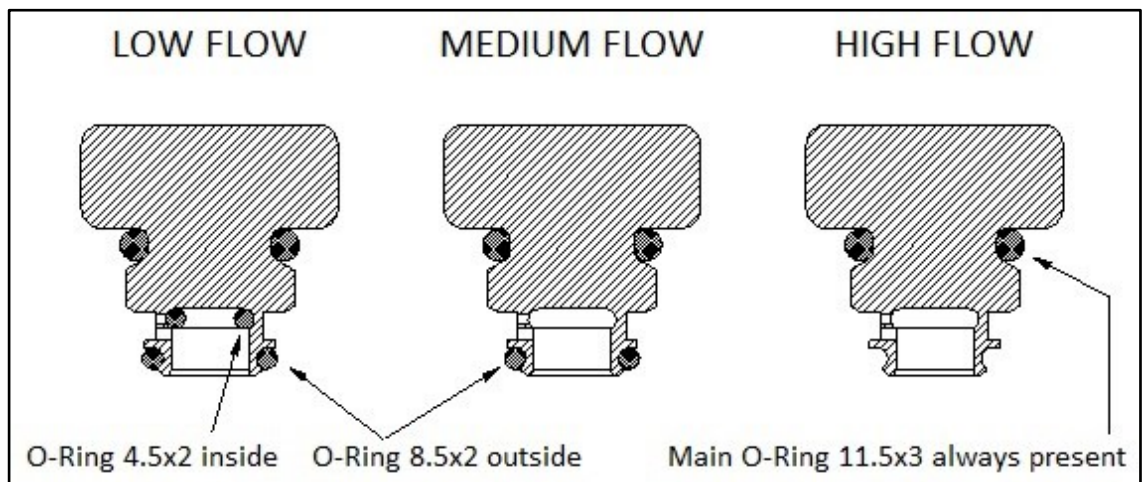

Figure 24. Flow Rate Adjustment Cell Cap

For instruments equipped with a MCU or an Automatic Cell Cleaning Device. Sample a higher or a lower flow rate can be adjusted.

- Low Flow:** Let the smaller O-Ring 9.5x2 inside the MCU/ Auto Clean
High Flow: Remove the smaller O-Ring 9.5x2.

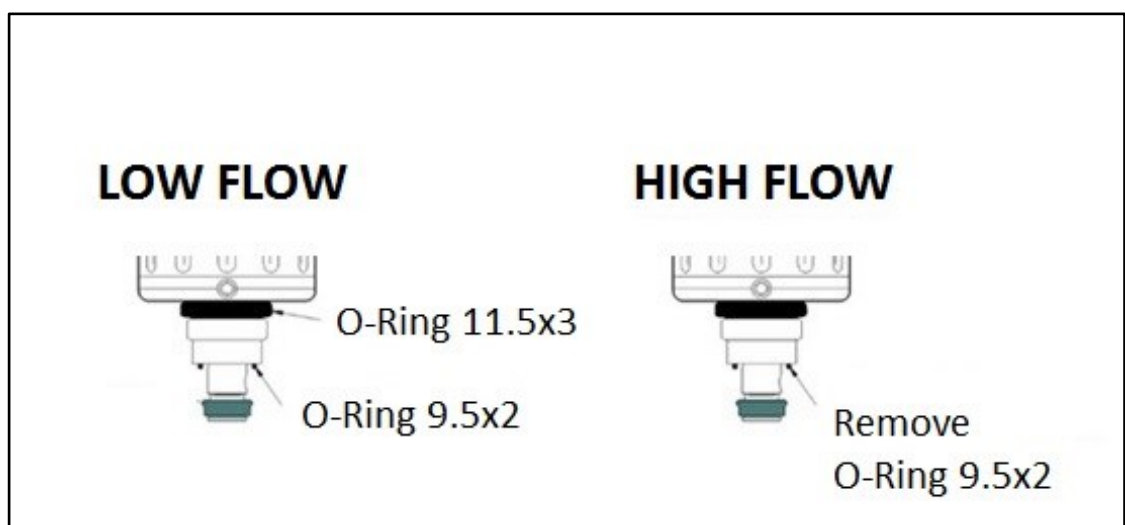

Figure 25. Flow Rate Adjustment Automatic Cell Cleaning Device/ MCU

For more information about the Flow Control and Cleaning Frequency, see 23.2.2 Functional Button "ON".



12.4 System Settings

At commissioning, alarms set points and alarm delays can be set. The signal output can be modified from 0 – 20 mA or 4 to 20 mA. According to external requirements also the offset can be set from -5 ppm to 5 ppm. Also, the settings can be reset to the factory default values, if needed.

For more information about the Settings, see 23.2.3

Functional Buttons AL1/ AL2/ SET.

12.5 Auto Clean Control Unit

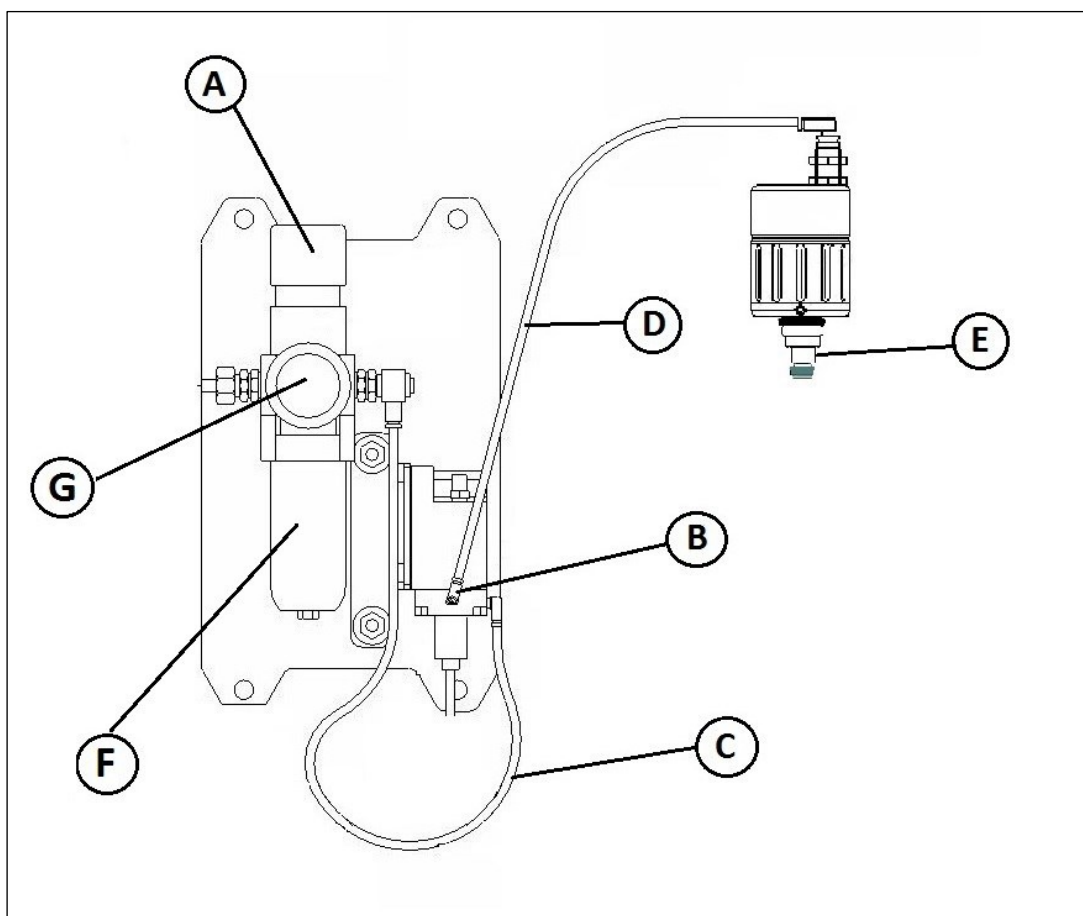

Figure 26. Auto Clean Control Unit

- | | |
|---------------------------|---|
| A. Air Regulator | E. Wiper Piston |
| B. Air Flow Adjuster | F. Transparent Bowl (Filter with water separator) |
| C. Air Regulator Hose | G. Ø 40mm Pressure Gauge |
| D. Air Flow Adjuster Hose | |



The Automatic Cell Cleaning Unit will not work without sufficient supply of pressurized instrumentation air. Make sure, that an air supply is installed. Further check, that the pipes are fixed correctly. Set the Air Regulator (A) output pressure to a pressure of approximately 4 - 6 bar. Too high-pressure settings can cause unnecessary wear. Low pressure may make operation unreliable. The Air Maintenance Unit consists of a transparent bowl (F), a pressure regulator (A) and Pressure Gauge (G).

12.5.1 Pressure Regulation

1. Pull the knob upwards.
2. Rotate the knob and set the pressure
3. Lock the set pressure by pushing the knob down.

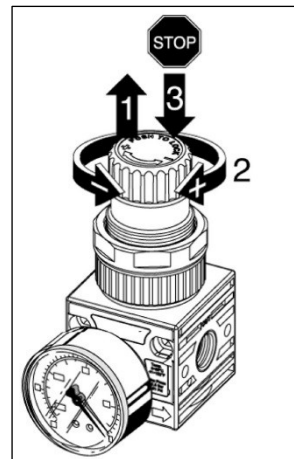

Figure 27 Pressure Regulation

12.5.2 Using standard drainage SS

- When the push button is positioned as in step **A**, drainage is semiautomatic, draining condensate when bowl is depressurized and locking up when bowl is pressurized. Push up the button to drain when bowl is pressurized.
- Then, rotating the button anticlockwise, drainage valve is manually closed, both when bowl is pressurized and depressurized, step **B**.

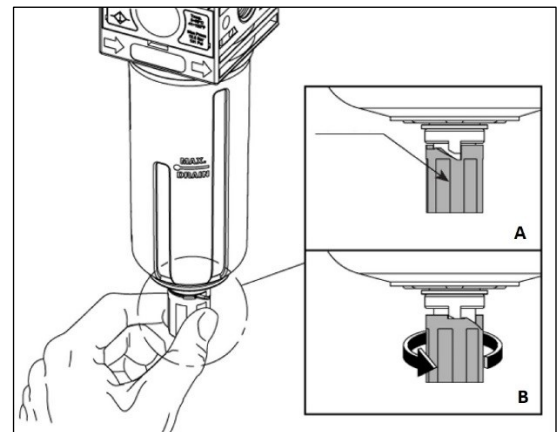

Figure 28 Using standard drainage



Please do not hesitate to contact DECKMA Hamburg GmbH for additional support.

i

Output Pressure set at the Air Regulator can be only reduced, if the cleaning sequence is activated repeatedly.

Open the air flow adjuster counter-clockwise about typically two revolutions with a screwdriver. Auto Clean should be activated repeatedly, while adjusting the air flow adjuster. The wiper piston should gently run up and downwards. Be careful, If the air pressure is too high, wiper piston will dash.



13. OMD-24 Series Operating instructions

When oily water flows through the instrument the oil content will be measured and the display will show the actual value of oil content.

If the oil concentration exceeds the adjusted threshold (works adjustment 15 ppm), the alarm indicator 1 will be illuminated in intervals during the selected time delay before it changes to steady light and the associated alarm relay will operate. Accordingly, also the alarm indicator 2 will be illuminated and its associated alarm relay will take the appropriate shut down action.

Whenever the instrument is switched over to FW, it will be in alarm condition as required by IMO.

Additionally, alarms and the separator status will be recorded in data logger to IMO Requirement every 15 seconds.

To switch over from sample water to clean water is depending on the instrument.

The OMD-24 is equipped with two independent valves for sample water and clean water. Valve handles are mechanically interlocked.

Do not use excessive force to operate the handles. The OMD-24 will only allow overboard discharge in Normal Operation setting of both valve handles.

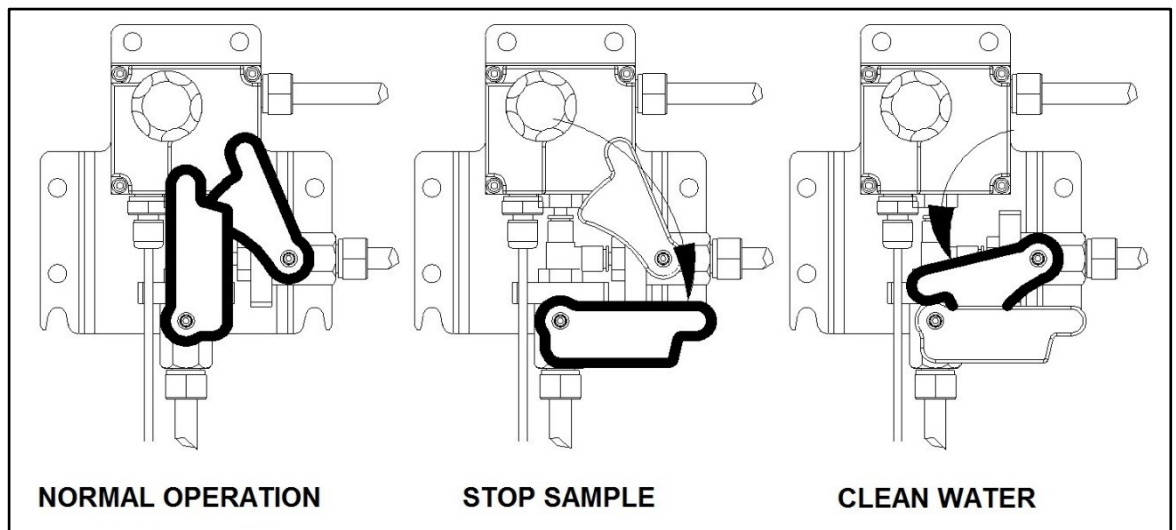

Figure 29. Operating Instructions OMD-24

The OMD-24 EV units have an electric switchover valve to switch over from sample water to clean water. Any operation is triggered via the front panel or triggered remotely. It will only allow overboard discharge in sample condition and has an external dry contact (see terminals 19&20). The Units will be in alarm condition, if fresh water is opened.



13.1 Cleaning Options

It is also recommended to use MCU or the Automatic Cell Cleaning device to clean the Measuring Cell.

Cleaning of the Sample Glass Tube could be simplified with a MCU or an Automatic Cell Cleaning Device.

Using the Manual Cell Cleaning Unit *MCU*:

- Ensure that there is a clean water supply through the cell.
- Activate the Manual Cleaning Unit by gently pressing the handle several times. Each time the handle is pressed, the wiper goes through the Sample Glass Tube once.
- Check, that the reading is between 0 to 2 ppm.
- Additional conventional cleaning with the Cell Cleaning Brush may be necessary.
- The MCU may also be used during operation with sample water. An alarm may occur, because the wiper is passing the light source.

Using the Automatic Cell Cleaning Device:

The Automatic Cell Cleaning Device can be set to cleaning intervals from a minimum of 1 minute to maximum of 8 hours (See 23.2.2 Functional Button "ON"). This cleaning sequence can be set from the display at all time. Even if the cleaning interval has been set before and is not finished. The setting of cleaning interval will initiate a cleaning cycle and store the setting.

i

It is recommended to assist the Automatic Cell Cleaning Device by manually cleaning the Sample Glass Tube at regular maintenance schedule, or as necessary.

If the Measuring Cell is equipped with a Cell Cap, please refer to section 14. Operator Maintenance.



14. Operator Maintenance

→ (See Section 2. Important Notes).

WEEKLY INTERVALS: 14.1 to 14.6 Data Logger Checking

MONTHLY INTERVALS: 14.7 MCU and Automatic Cell Cleaning Device

The Operator Maintenance should be scheduled at least once a week. If needed, prepare the Quick Check List to keep track on maintenance. For more information, see section 25.1 Operator Maintenance Quick Checklist.

14.1 General Test

- a) Visually inspect instrument for obvious leakages or damage.
- b) Visually check condition of cables and connections.
- c) Check the desiccator:
 - Press **"SYS"** button, select Measuring Cell, confirm.
 - Internal data is displayed. Identify Dew Point Temperature [°C] and relative humidity [%rH] data.

The relative humidity [%rH] should be below 10%rH. Dew Point Temperature should be below 0°C. If not, desiccator exchange is recommended. For more information, see section 23.2.4 Functional Button **"SYS"**.

14.2 Normal Operation

- d) Switch the Electrical Valve or manual valve to fresh water, so that the cell is flushed with oil free water. Check 23.2.2 Functional Button **"ON"**.

i

When operated via the front panel the Electrical Valve will automatically switch back to normal operation (sample stream measurement) after approximately 120 seconds of clean water flushing.

For operating the Electric FW Valve press the **"ON"** button, select **"FW FLUSH"** change the Status to **"ON"**. The EV-Valve will switch over to fresh water immediately and remain in fresh water setting for 2 minutes before switching back to normal operation. If a prolonged flushing is desired, it can be retrigged within the 2 minutes, or repeated afterwards.

Anytime the EV-Valve is switched to fresh water, the OMD-24 will be in alarm condition, as required by IMO MEPC.107(49). If the instrument is switched on to FW remotely, it will remain so until the remote signal is changing.

- e) Let the oil free water flow for few minutes.
- f) Verify that the display is showing 0 to 2 ppm. If this is the case, continue with the steps r) to t).



14.3 Cleaning Process



- g) Stop any water flow.
For instruments equipped with Automatic Cell Cleaning Device, shut off the instrument air.
- h) Unscrew and remove the Cell Cap. Visually check the wiper piston and the O - Rings for wear or damage.
- i) The wiper seal should be clean.
- j) It is recommended to clean the Measuring Cell on a regular schedule manually using the Cell Cleaning Brush with upwards and downwards motion through the entire length of the cell several times.
- k) For oily deposits use a mild detergent on the Cell Cleaning Brush.
- l) Put back the Cell Cap, and the wiper piston. Make sure that the Cell Cap is screwed in completely.
- m) Purge with oil free water for several minutes to get a clean Measuring Cell.
- n) Verify that the display is showing 0 to 2 ppm.
- o) For instruments equipped with Automatic Cell Cleaning Device, restore the air.
- p) Turn on the sample water flow.

14.4 Intensive Cleaning

- q) If there is no improvement, repeat cleaning with the Cell Cleaning Brush and use Sample Tube Cleaner and check in contemporary the display, if the "0" point is achieved. The process could take about 5 minutes. Shouldn't the result improves again, use Citric Acid and let act on over the night.
 - Cut the upper part of the Cell Cleaning Brush.
 - Insert the wire stem of the Cell Cleaning Brush into a screwdriver and fix it.
 - Slowly rotate the Cell Cleaning Brush for a few minutes in the Sample Glass Tube.
 - Flush with clean water and re-test.

For more information, see section 26.1 Servicing and Cleaning Manual.

14.5 System Test

- r) Perform a "System Test" for checking the alarms contacts. See section 23.2.1 Functional Button "TEST".
- s) The "System Test" is only useful, if the oil content is under 15 ppm before starting the test.



14.6 Data Logger Checking

- t) Check the data logger:
 - 1. Is the data logger recording the data?
 - 2. Check the clock for time deviation.

For more information, see section 15. Programming Mode.

14.7 MCU and Automatic Cell Cleaning Device

- a) Stop water flow and air supply, respectively.
- b) Check the wiper seal and the O-Rings. Clean if necessary. The wiper piston can be pulled out easily. It is magnetically coupled.
- c) To reinsert just put the wiper back. The magnetic coupling will arrest it.

i

Both MCU and Automatic Cell Cleaning Device may require additional manual cleaning. Check the Sample Glass Tube condition and correct working of cleaning systems at regular maintenance schedule.

→ **Remarks:**

The automatic cleaner will not work without sufficient supply of pressurized instrumentation air.

If the wiper is not correctly installed, the wiper piston may proceed to its lower position, thus blocking the measurement region of the Measuring Cell Glass Tube. This can cause false alarms and error conditions.

A worn out or damaged wiper seal may fail to properly clean the Sample Glass Tube. A damaged or missing wiper seal may lead to permanent damage due to scratching the Sample Glass Tube surface.



With excessive air pressure while the automatic cell cleaning device is taken out of the Measuring Cell, if the cleaning system operates, the wiper may be thrown out. Handle with care to avoid loss of wiper, and avoid risk of injury.



It is recommended to wear safety goggles and safety gloves while handling chemicals.



14.8 Maintenance Recommendations

Maintenance recommendations for 15 ppm Bilge Alarms OMD-24 Series

IMPORTANT

**NEVER DISASSEMBLE THE UNITS AS THIS MAY VOID
CALIBRATION AND CERTIFICATION!**

CLEANING HAS ONLY TO BE DONE THROUGH THE REMOVED CELL CAP BY USING THE CELL
CLEANING BRUSH!

In some cases of unexpected high ppm readings with clean water the Measuring Cell has a problem with internal coating of the Sample Glass Tube. Just cleaning with brush and clean water does not always help in this case. Additional cleaning is required.

Please carry out the following instructions to make sure that the Sample Glass Tube is really clean. Then the unit will show 0 to 2 ppm with clean water.

In certain cases, depending on environmental conditions on site, Iron Oxide may be deposited inside the Sample Glass Tube (brownish surface deposit on the Sample Glass Tube). To remove Iron Oxide, it is recommended to use Citric Acid. Drain the instrument, fill Citric Acid into the Sample Glass Tube, add water and let it soak overnight. Flush with clean water. If situation improves, repeat until success. Other deposits may be removed with a mild acidic cleaner.

Additional use of tooth paste may also assist in cleaning as a last resort. Do not use abrasive cleaners containing hard particles. Hard abrasive particles may scratch the glass surface, permanently damaging the instrument.

Clean the Sample Glass Tube by using the Cell Cleaning Brush and a mild cleaning agent.

The Measuring Cell is expected to read 0 - 2 ppm, if successfully cleaned.

Another possible cause of unexpected high ppm reading: Check Measuring Cell humidity readings and desiccator status. Press "**SYS**" button, select Measuring Cell, confirm. Internal data is displayed. Dew Point Temperature [°C] should be below zero Degree Celsius, relative Humidity [%rH] should be below 10%rH. If above values are exceeded, renew desiccator and allow new desiccator to absorb the humidity inside the Measuring Cell.



15. Programming Mode

There are 3 groups of push buttons to control the functions of the display. Navigation buttons are in group 1. Functional buttons are group 2. Group 3 is for data logger operation.

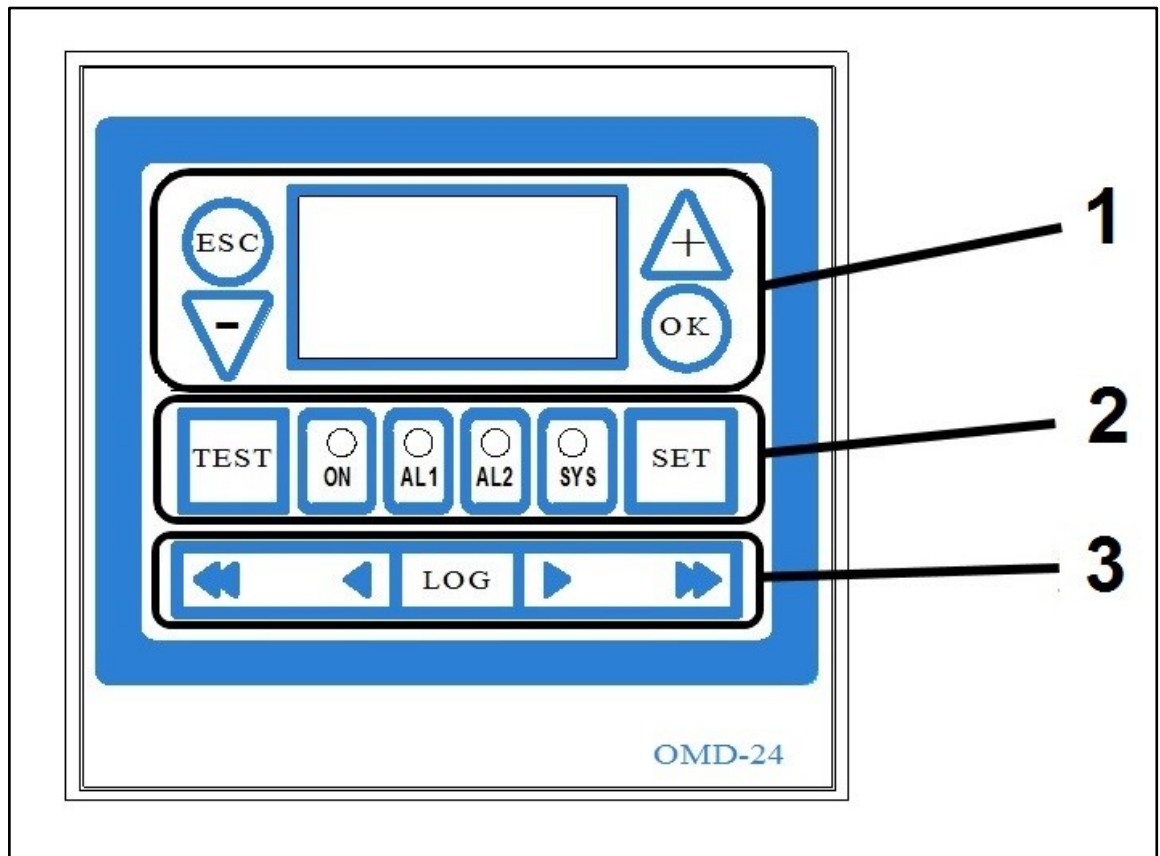

Figure 30. Display Functions

1. Navigation Buttons

With the Navigation Buttons, some setting can be adjusted, confirmed or actions can be canceled before confirmed. The display shows status Information. (See section 23.1 *Navigation Buttons for more details.*)

2. Functional Buttons

The Functional Buttons provide a direct access to certain settings. Alarm set points 1 or 2, alarm delays 1 or 2, the Offset, and the Output can be modified. By selecting “set default” all the settings can be reset to the factory default values as well.

Also, instrument specific information like type, serial number, and certificate information can be displayed. Additionally, it is also possible to read information about the Measuring Cell, and internal data on temperature, humidity, dew point etc.



DECKMA

HAMBURG

With the **“TEST”** button system test can be performed. Additionally, the Desiccator Status can be checked. (See section 23.2 *Functional Buttons for more details.*)

Also, cleaning interval at OMD-24 EVA can be managed from minimum 1 minute and maximum 8 hours. By “0” Autoclean will be off.

3. Data Logger Operation Buttons











The **“Log”** buttons are used to operate the integrated data logger. These buttons show a live display, in which the current data from alarm status, the external separator additionally, the oil content, the device status, and a reserve is recording to IMO Requirements. That data can be shown as a graphical or a text-based recording at any particular time. All the information will be recorded every 15 seconds. All recorded data is available for more than 18 months.

With the arrow buttons the data can be navigated.

The internal clock is factory set for GMT, **Greenwich Mean Time** and cannot be changed or adjusted. The internal clock is adjusted to be within +/- 2 minutes of GMT in production. A few minutes of derivation per year of operation should be expected. (See section 23.3 *Data Logger Operation Buttons for more details.*)

➔ See Section 23. *Appendix for more details about the buttons.*

15.1 Buttons

Buttons	Description
	Pressing this button once, it is possible to return to the previous menu. Pressing this button twice, it is possible to return to the “Normal Operation” display.
	Navigates to the next or previous option.
	Navigates to the next or previous option.
	By pressing this button, it is possible to select and confirm entry.
	Pressing this button, directly leads into the “SYSTEM TESTS” menu.
	Pressing this button, directly leads into the “SYSTEM-OPTIONS” menu.
	Pressing “AL1/2” buttons, leads into the “SETTING,def.” menu.
	Pressing this button, leads directly into the “SYSTEM info” menu.
	Pressing this button once, leads into the “SETTING,def.” menu. Pressing the button twice leads into “DEFAULT” menu.
	Pressing this button once, leads into the “DATA LOG live” menu, if the memory card is activated. Pressing this button twice, the recorded data display mode will be invoked and graphical recorded data appears. Pressing this button if a non-activated memory card is inserted, leads to the menu to activate the memory card.
	It is possible to press and slide the “Arrow” sliders (right/ left), to navigate to the data or time of recorded data, in the graphical recorded data menu.



16. Memory Card

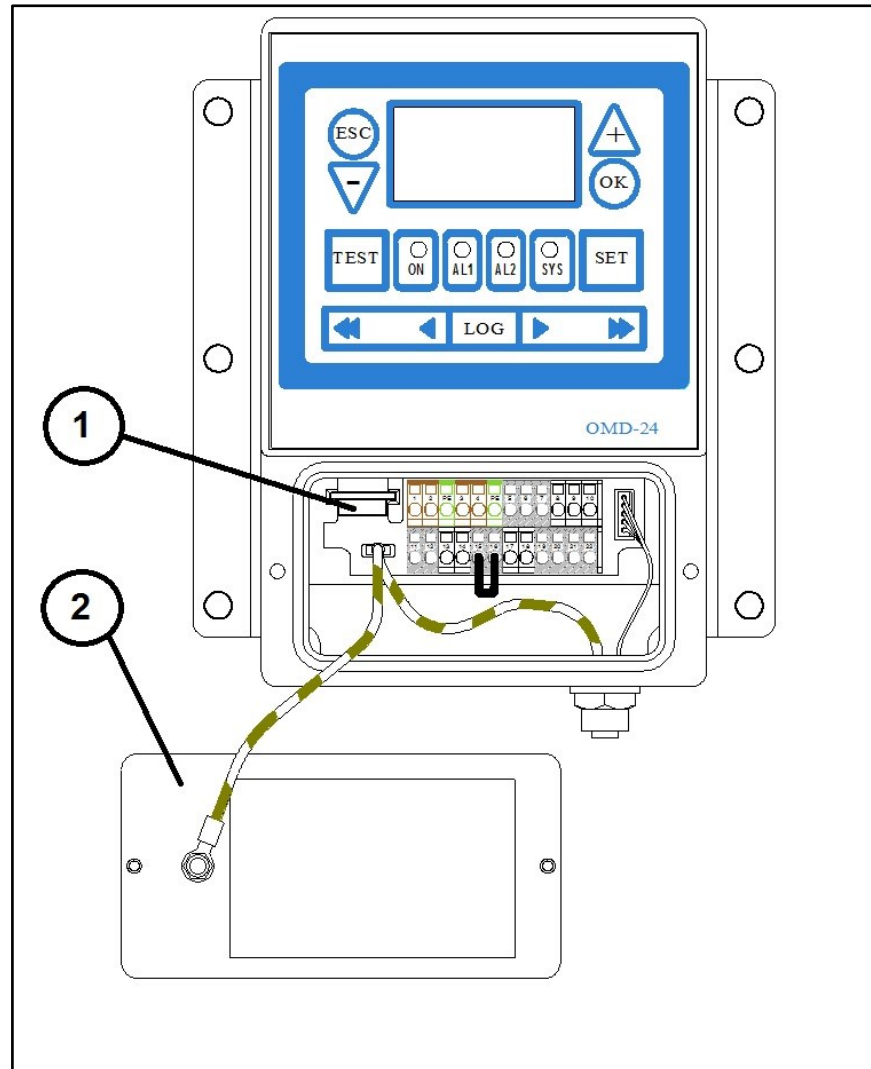

Figure 31. Memory Card Location

1. Memory Card
2. Terminal Cover

The Memory Card is located next to the terminals in the computer housing. It is sufficient for the life of the instrument, and it ensures to the required storage time of at least 18 months according to MEPC.107(49). When the card is completely used, the oldest entry will be overwritten, so that a replacement is not necessary. Under normal use the card should not be taken out. The memory card is registered with the specific instrument. The card can be read in other OMD-24 units, but writing is only possible in the related system.

If no memory card is mounted, if the memory card is defective, or a card from another system is inserted, the unit will be in alarm condition **“Status: Datalog”**.



16.1 OMD-CR Memory Card Reader

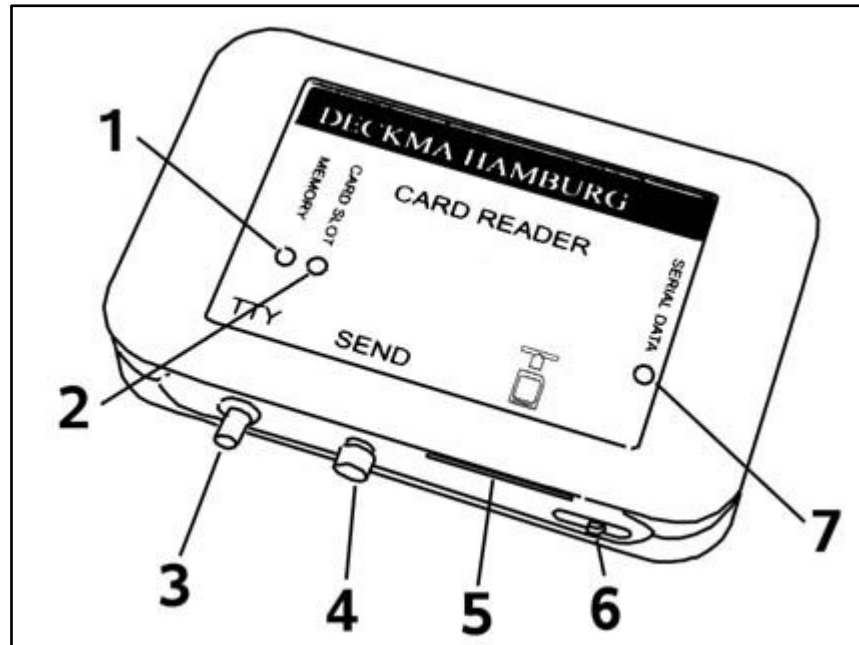

Figure 32. OMD-CR Memory Card Reader

1. Memory LED
2. Card Slot LED
3. Serial Interface Connector
4. SEND – Button
5. Card Slot
6. On-Off Switch
7. Serial Data LED

DECKMA Hamburg oil in water monitors store certain data according to IMO Requirements in a memory card. The data stored by any OMD-24 Unit can be displayed with any other OMD-24 Unit.

Additionally, the data can be accessed with the DECKMA HAMBURG OMD-CR card reader. The OMD-CR card reader allows to copy certain memory card data to a file on a computer, so that it can be processed, browsed, or printed, with only brief interruption of the 15 ppm Bilge Alarm Monitor operation. Please note that only the data requested by MEPC.107(49) (Date, Time, Alarm Status, Separator Status) can be copied to the computer.



17. Fault finding

→ See Section 2. *Important Notes.*

The OMD-24 Series will indicate several malfunctions in the status line of the display. Pressing the **“OK”** button will display additional information.

Status	OK		
Reading	0..15	15..49	EE
System Alarm LED	Green/ Blinking		
Alarm Circuit 1,2	No Alarm	Alarm	
Reason	Low oil content.	Normal Operation.	Sample reading is out of range: -oil content too high. -dirty Sample Glass Tube. -Air bubbles in sample stream.
Recommendations	-Continue operation. -Apply standard maintenance schedule.	Resume normal maintenance schedule.	-Wait until oil content is within the range. -Clean Sample Glass Tube.

Status	FW!	Flow!	EVALVE?
Reading	0..49/ EE		Any
System-Alarm-LED	Green/ Blinking		Red
Alarm Circuit 1,2	Alarm		
Reason	- Freshwater is enabled. - Remote fresh water input is linked (Terminals 19 -> 20). -defective/ missing magnetic holder	-Terminals 15&16 open. - A magnet is missing. - Flow sensor unsatisfied. - Magnet sensor defective.	EV FW Valve position not detected. (For EV Units only)
Recommendations	- Switch back to sample stream. -Remove/ Check external wiring. -Replace the magnetic holder.	Check sample flow rate.	Check connectors and wiring.



Status	Com?	Sample?	Data log?
Reading	EE		0..49/EE
System-Alarm-LED	Red/Steady		
Alarm Circuit 1,2	Alarm		
Reason	No communication between Computer Unit and Measuring Cell.	Meter is not able to measure the sample: no water in, oil content much too high no light transmission possible.	Data logging is not possible: No DECKMA memory card inserted. A read only card has been inserted. -A new DECKMA memory card has been inserted, but has not been activated.
Recommendations	Check connection between Computer Unit and Measuring Cell.	-Check sample, check sample flow rate, clean Sample Glass Tube according to section13. OMD-24 Series Operating instructions	Insert the active memory card. New memory card. Activate the memory card.

Status	Int.Err	Desicc.	Humid
Reading	0..49/EE		
System-Alarm-LED	Red/Steady	Green/ Blinking	
Alarm Circuit 1,2	Alarm	Normal Operation	
Reason	Internal error.	Measuring Cell Humidity critically high (>40%rH)	Sample temperature below dew point. Instantaneous condensation possible.
Recommendations	Restart the system.	Check/ Replace desiccator.	Check/ Replace desiccator.



17.1 Automatic Cell Cleaning Unit Fault Finding

Fault	Explanation	Solution
Pneumatic Cleaner not operating	Air pressure low.	Restore air pressure.
	Air connections missing or wrong.	Sort out air connections. Air connections are Push-In type. Press release ring to release hose.
	Auto Clean interval set to "OFF".	Activate cleaner via menu.
	Auto Clean interval set to long interval, time not yet expired.	Wait for time to expire, or manually trigger cleaning cycle. Refer to section 23.2.2 <i>Functional Button "ON", "Change of cleaning frequency"</i> .
Wiper moving very slowly	Air flow adjuster too stringent.	Turn Adjuster on Auto Clean Control counter-clockwise with a screw driver.
	Wiper or Cylinder not clean.	Clean wiper.
Wiper moving very fast	Air flow adjuster too wide.	Turn Adjuster on Auto Clean Control clockwise with a screw driver.
Cleaning insufficient	Cleaner not operating.	Check wiper and air supply.
	Debris deposits.	Try additional manual cleaning.
	Deposition of material that cannot be removed mechanically (e.g. Iron Oxide.)	Try chemical removal of deposit. Apply Cleaning Kit. Iron Oxide can be removed with Citric Acid.
	Cleaner frequency not adjusted to situation on site.	Adjust cleaner frequency.
	Wiper seal worn out or damaged.	Replace wiper seal.
	Wiper piston missing.	Re-install wiper piston.



Please do not hesitate to contact DECKMA Hamburg for additional support.



18. Calibration

18.1 OMD-24 Series

15 ppm Bilge Alarms built according MEPC.107(49) have to be protected against access beyond the checks of instrument drift, repeatability of the instrument reading and zero adjustment. For this reason, the instrument is electronically sealed, so that only the manufacturer or his authorized persons, equipped with the related tools, are able to get access for changing the calibration.

To provide a simple procedure to check the instrument aboard ship, the OMD- 24 Series is constructed in that way, that the zero check also confirms the instrument drift within the specifications.

18.2 Calibration and Repeatability Check

- a) Switch off the power supply and stop any water flow.
- b) Clean the Sample Glass Tube accurately by using a suitable Cell Cleaning Brush as described under Section 14. *Operator Maintenance.*
- c) Run clean water through the instrument.
- d) Make sure that non-aerated, clean water is in the instrument. The reading should be $0 \text{ ppm} \pm 2 \text{ ppm}$.
- e) Continue as described under Section 13. *OMD-24 Series Operating instructions.*

i

Please note: MEPC.107(49) wording regarding instrument calibration:

MEPC.107(49) Section 4.2.11:

[Quote]

The accuracy of the 15 ppm Bilge Alarms should be checked at IOPP Certificate renewal surveys according to the manufacturer's instructions. Alternatively, the unit may be replaced by a calibrated 15 ppm Bilge Alarm. The calibration certificate for the 15 ppm Bilge Alarm, certifying date of last calibration check, should be retained on board for inspection purposes. The accuracy checks can only be done by the manufacturer or persons authorized by the manufacturer. [End Quote]



DECKMA
HAMBURG

18.3 Function Test at Classification Survey and Port State Control

All 15 ppm Bilge Alarms leaving our works are calibrated according the requirements with an accuracy of better than ± 5 ppm within the measuring range. The alarm points are preset to 15 ppm (or 5 ppm for instruments limited to 5 ppm set point see section 19. OMD-24 Series with 5 ppm Alarm Set Point), and can only be changed to a lower value on site. A setting to a higher value is not possible.

To provide a simple procedure for instrument check aboard ship, the OMD-24 Series are constructed in that way, that the zero check also confirms the instrument drift within the specifications. The ***“TEST”*** button (see 23.2.1 Functional Button ***“TEST”***) starts a self-test routine and allows to put both alarms contacts into alarm condition. The instrument will count down from an assumed high reading (30 ppm) downwards until the assumed value is equal to the actual measured ppm value.

i

Note that this test will only switch the alarm contacts to non-alarm condition, if the sample contains less than 15 ppm oil content and all other conditions for proper measurement are OK.



DECKMA
HAMBURG

19. OMD-24 Series with 5 ppm Alarm Set Point

By request the OMD-Series instruments (OMD-24/ OMD-24 EV/ OMD-24 EVA/ and OMD-24 A) are also available with alarm set points limited to 5 ppm for both alarms (alarm 1 and alarm 2).



20. Spare Parts

When ordering spares, it is important to supply details of the type of monitor, instrument serial number, instrument date of commissioning, part number of each spare required, its description and any relevant serial number.

OMD-24 Series	OMD-24	OMD-24 EV	OMD-24 A	OMD-24 EVA
Alarm Set Point Limitation	10810/15ppm 10812/ 5 ppm	10811/15 ppm 10813/ 5 ppm	10814/15 ppm 10816/ 5 ppm	10815/ 15 ppm 10817/ 5 ppm
DESCRIPTION	ART-NUMBER			
Desiccator	79550	79550	79550	79550
Cell Cleaning Brush	77555	77555	77555	77555
O-Ring Set	77775	77775	77773	77773
Push-In Fitting PVC	79412	79421	79412	79421
T-Piece PVC	79415	79422	79415	79422
Measuring Cell	77500	77500	77500	77500
Service Exchange Measuring Cell (incl. new Calibration)	2277500	2277500	2277500	2277500
Electric Valve for OMD-24 EV		13215		13215
Wiper Seal			77606	77606
Service Kit	18570	18570	18570	18570
Memory Card	79186	79186	79186	79186
Wiper, complete with Wiper Seal			77792	77792
Air pressure filter/ regulator unit			16270	16270
Set of push in connectors and hoses			78770	78770
Auto Clean Controller Assembly			78790	78790
Auto Clean Actuator Assembly			78780	78780
Pneumatic Cylinder			78785	78785
Solenoid Support		79019		79019
Conversion-Kit to OMD-24 FC	56250			



20.1 Recommended On Board Spares

QTY.	OMD-24 Series	OMD-24	OMD-24 EV	OMD-24 A	OMD-24 EVA
	ART-Number/ Alarm Set Point Limitation	10810/15ppm 10812/ 5ppm	10811/15ppm 10813/ 5ppm	10814/15ppm 10816/ 5ppm	10815/ 15ppm 10817/ 5ppm
	DESCRIPTION	ART-NUMBER			
1x	Measuring Cell	77500	77500	77500	77500
2x	Desiccator	79550	79550	79550	79550
1x	Cell Cleaning Brush	77555	77555	77555	77555
1x	O-Ring Set	77775	77775	77773	77773
1x	Electric Valve for OMD-24 EV		13215		13215
2x	Wiper Seal			77606	77606
1x	Service Kit	18570	18570	18570	18570
1x	Set of push in connectors and hoses			78770	78770
1x	Pneumatic Cylinder			78785	78785
1x	OMD-CR Memory Card Reader	75185	75185	75185	75185
	Optional Item				
1x	Manual Cleaning Unit	77780	77780		
1x	Solenoid Support		79019		79019
1x	Flow Sensor	16700			
1x	Sensor PCB	56300			
1x	Y-Cable	56810			
1x	Flow Laminator Pipe (Length = 100 mm)	56420			
1x	Fitting 1/4" 6mm OD	20521			
1x	Connection 8 pin	56821s			



DECKMA
HAMBURG

21. Optional Equipment

Equipment	Art-Number
Manual Cleaning Unit (MCU)	77780
Wiper Seal for MCU	77606
OMD-CR Memory Card Reader	75185
Calibration Check Kit	18515
Auto Clean Controller Assembly	78790
1 off Service Kit	18570



23. Appendix I.

The OMD-24 Series Touch Display consists of several buttons and LEDs. Each button/LED has its own specific function. It is possible to call, activate/ deactivate, adjust and set certain display status. Further it is possible to perform certain commands directly via display. In the following, it is described particular display status by pressing a combination of buttons.

If you press the “ESC” button from a particular display status only once, the display will jump back one level. Pressing the “ESC” button twice, will bring you to the “initializing display”.

23.1 Navigation Buttons



Pressing one of the tagged buttons, let the “Normal Operation” display appears.

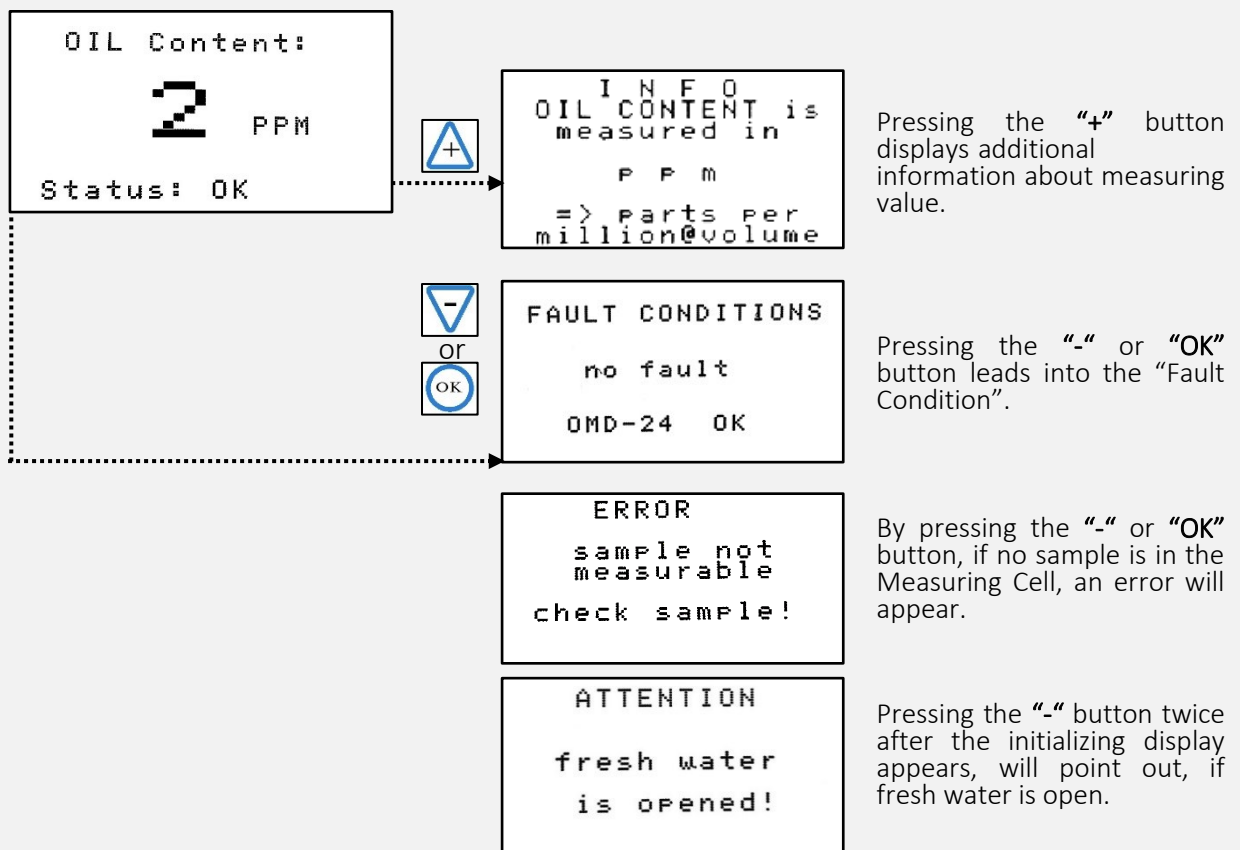

➔ Refer to Fault Finding Table in manual for explanation of status information.



23.2 Functional Buttons

23.2.1 Functional Button "TEST"

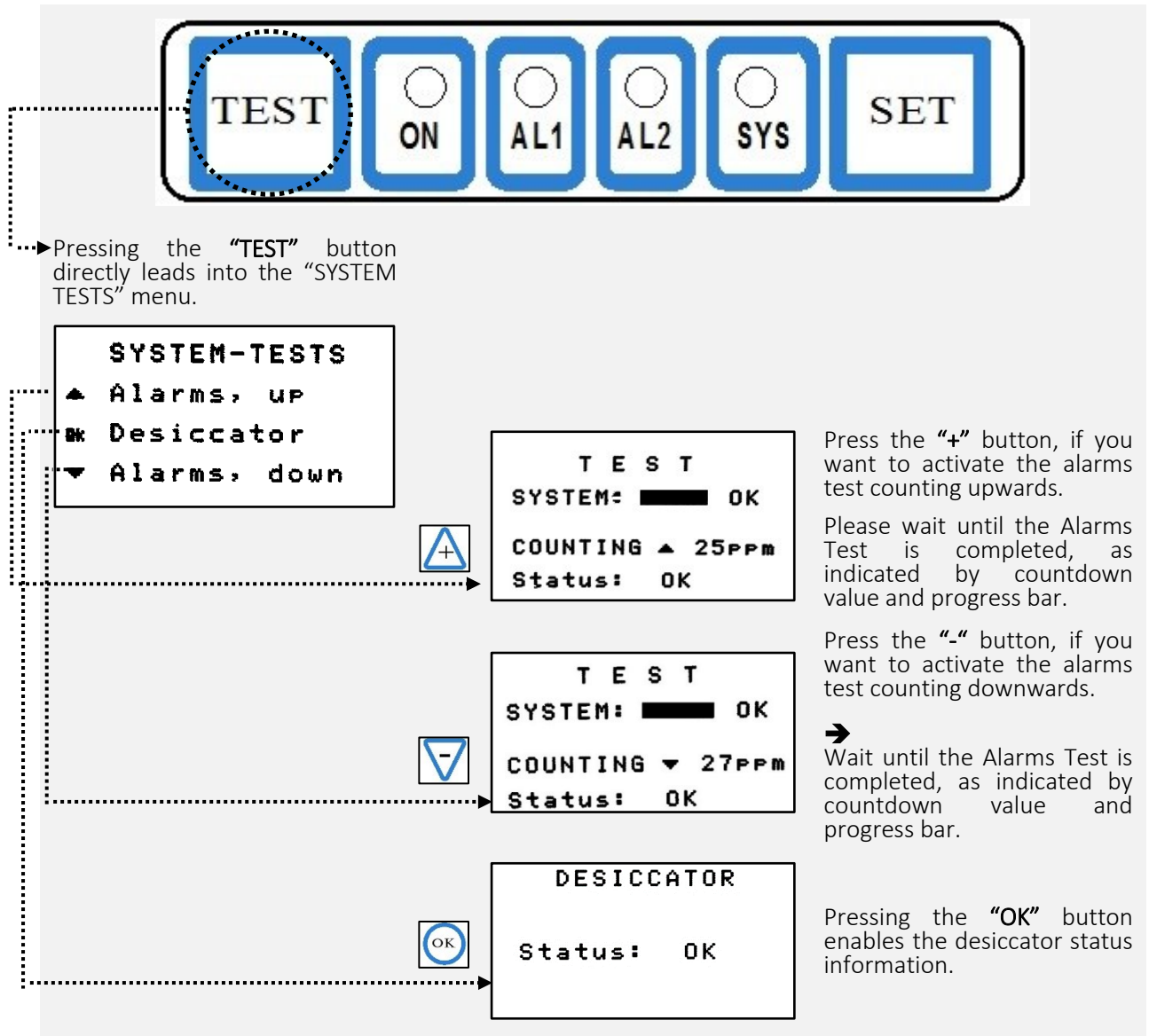



23.2.2 Functional Button "ON"

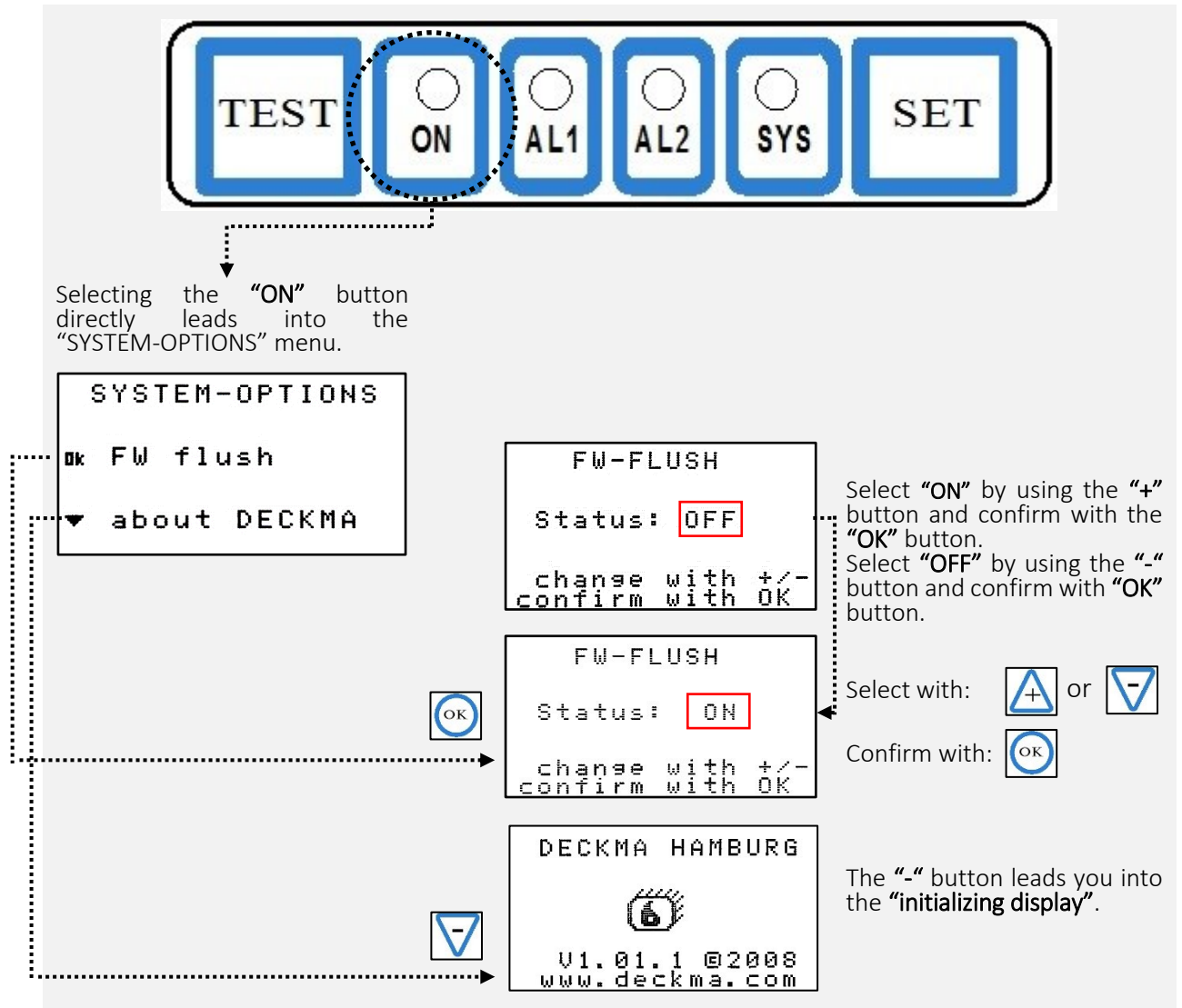



The OMD-24 EVA tools menu has an additional entry ("AUTOCLEAN").

You can adjust the cleaning frequency according to the water quality on site, by pressing the "ON" button.

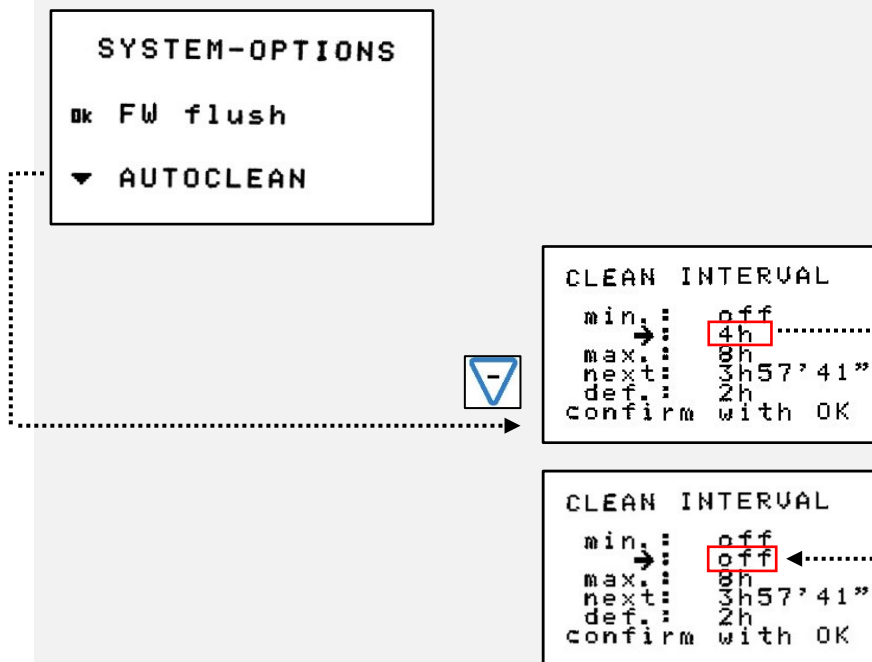

Pressing the "-" button leads into the "CLEAN INTERVAL" display.

In this display status it is possible to check and set the time delay setting for Autoclean operation from minimum 1 min. to maximum 8 hours. Alternatively, it is possible to switch off the Autoclean completely.

Less than 2 hours is not recommended. It can lead to mechanical wear and decreased lifetime.

Line "next" displays the remaining time towards the net cleaning cycle. This is especially useful, if remaining very long (several hours) cleaning intervals.

By selecting "def." the cleaning interval will be set to 2 hours.

Select the required point by using the "" or "-" button and confirm with "OK" button.

The Autoclean interval should be off, if it is uncertain, that a sample stream is maintained. If the cleaner operates in a dry Sample Glass Tube, increased wear is to be expected.



23.2.3 Functional Buttons AL1/ AL2/ SET

Pressing "AL1", "AL2", or "SET" button leads into the "SETTINGS, def" menu. At the SETTINGS, def." menu the alarms, time delays, the offset, the gain, and the output signal can be modified within the limitation. And the unit could be also reset to factory default values there. Pressing the "SET" button in the "SETTINGS, def." menu leads into the particular values, where the limitation can be adjusted.

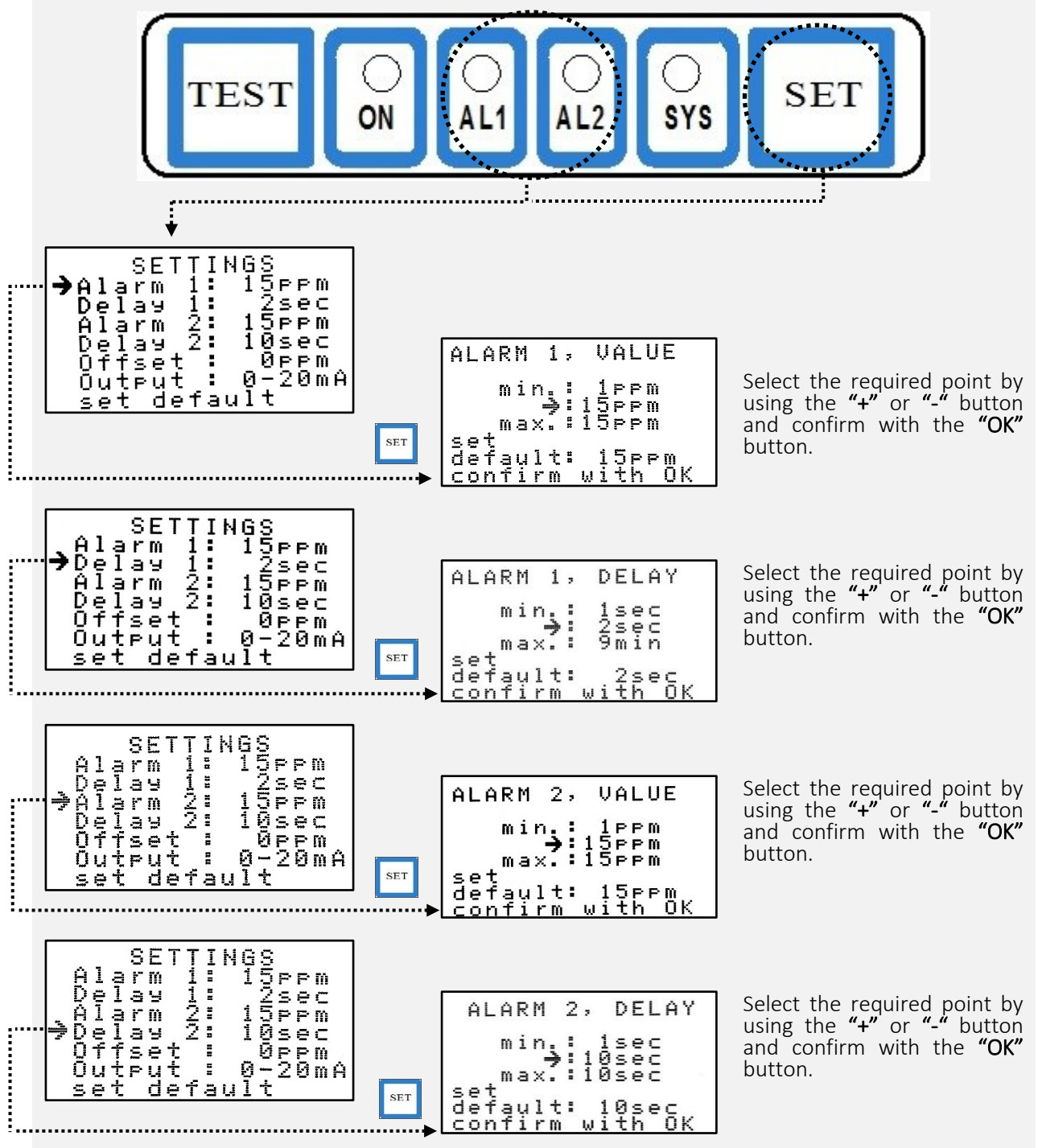



DECKMA

HAMBURG

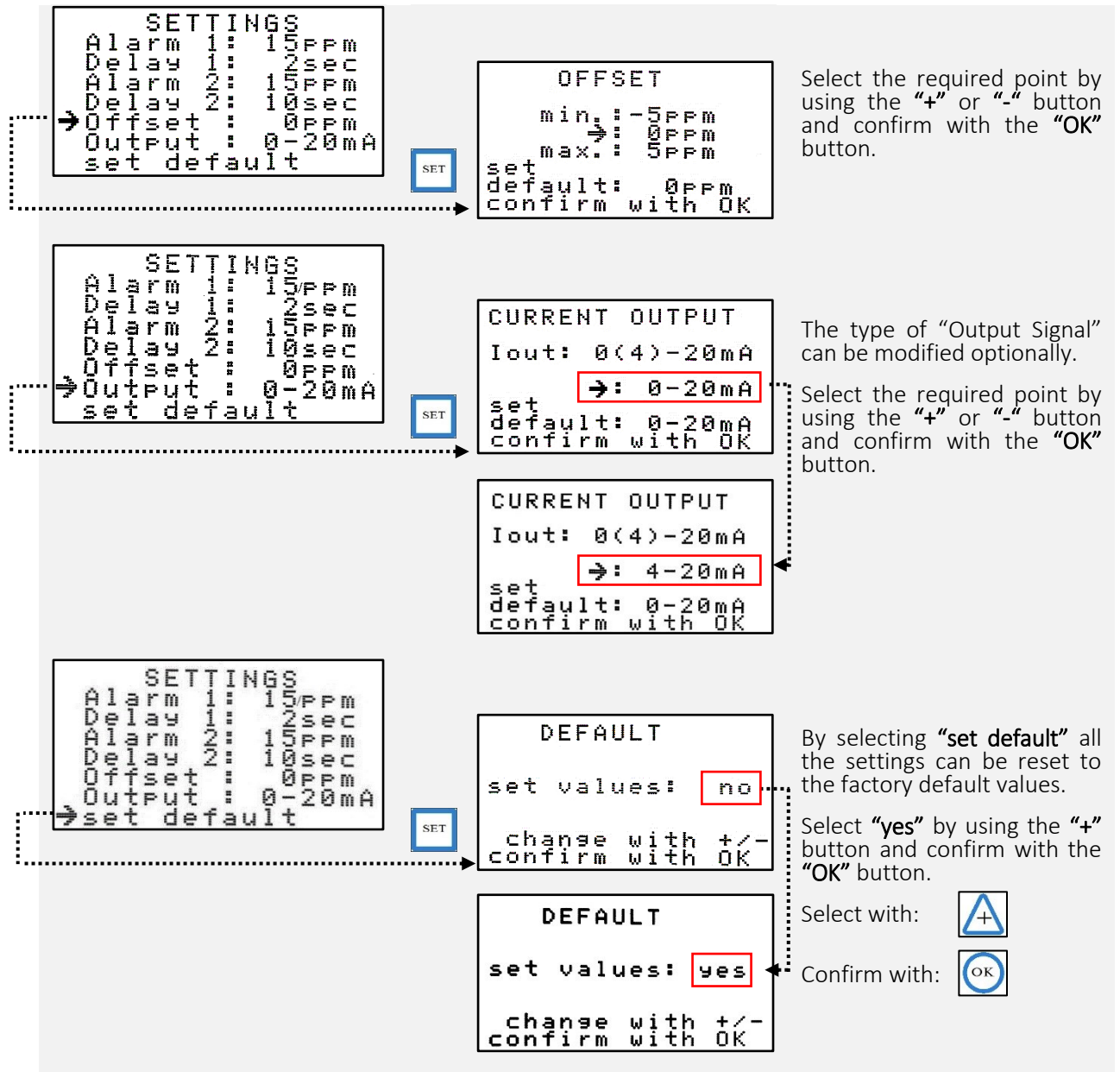



23.2.4 Functional Button "SYS"

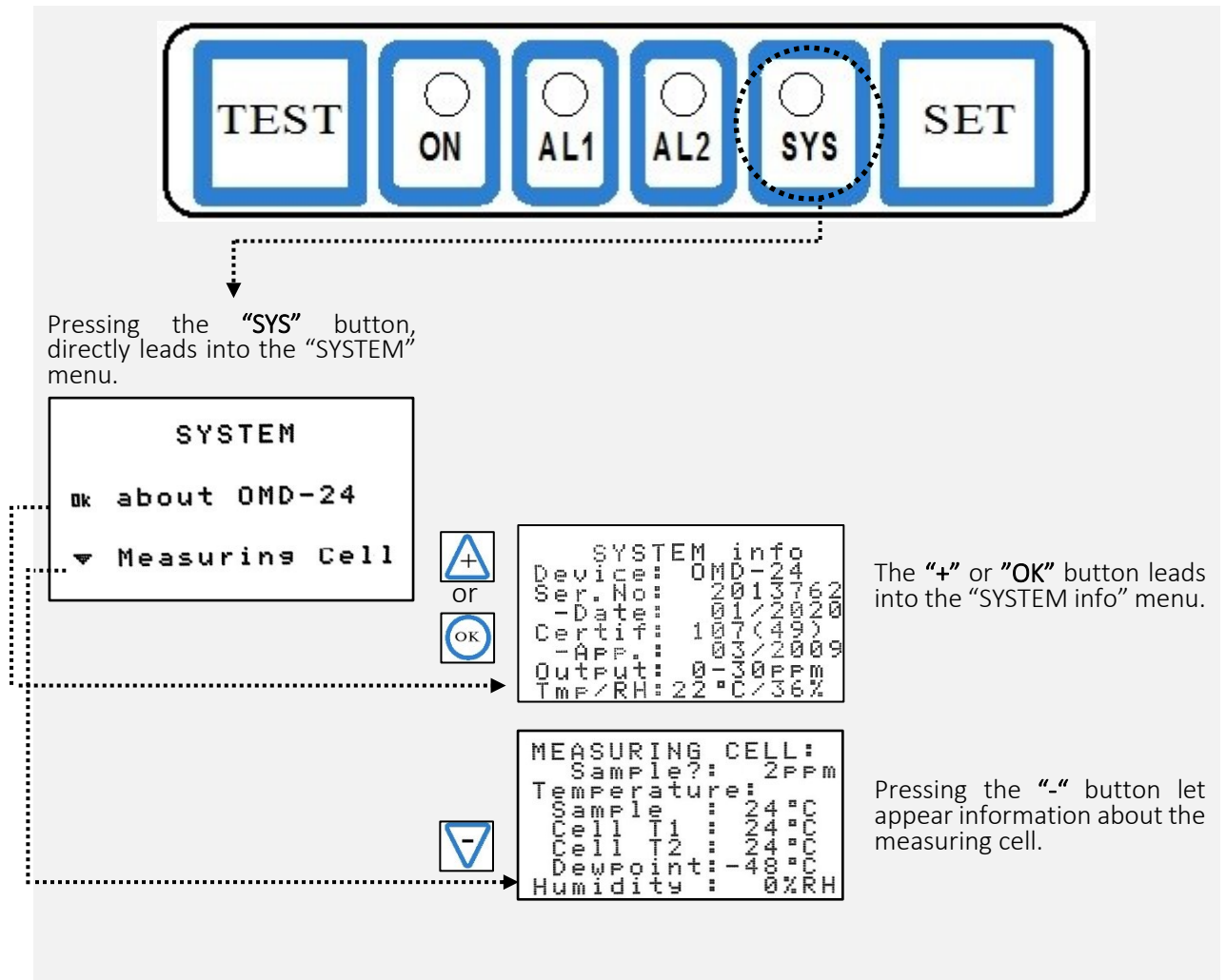



23.3 Data Logger Operation Buttons



The "LOG" button leads into the data logger function.

The "LOG" button leads into the data logger function.

Initially the data logger displays the live data.

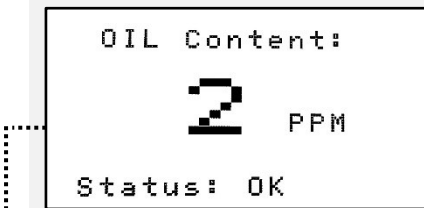

By pressing the "LOG" button again, the recorded data display mode is invoked and the graphical recorded data appears. by pressing the "LOG" button again, you will change into the non-graphical recorded data.

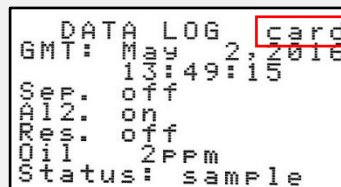
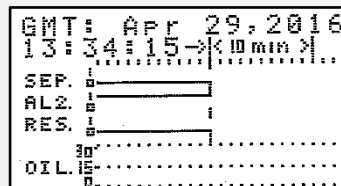
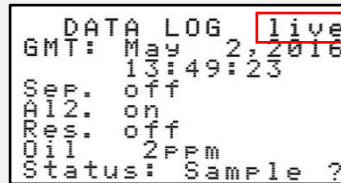

The "Arrow" sliders can be used to navigate to date or time recorded data.



For leaving the non-graphical recorded data, press the "ESC" button once. The live data appears.



23.4 Activating the Memory Card



If you have inserted a new DECKMA memory card, you have to activate the memory card as follows.

After pressing the "LOG" button twice, the display will appear with the information, if you want to activate the new DECKMA memory card.

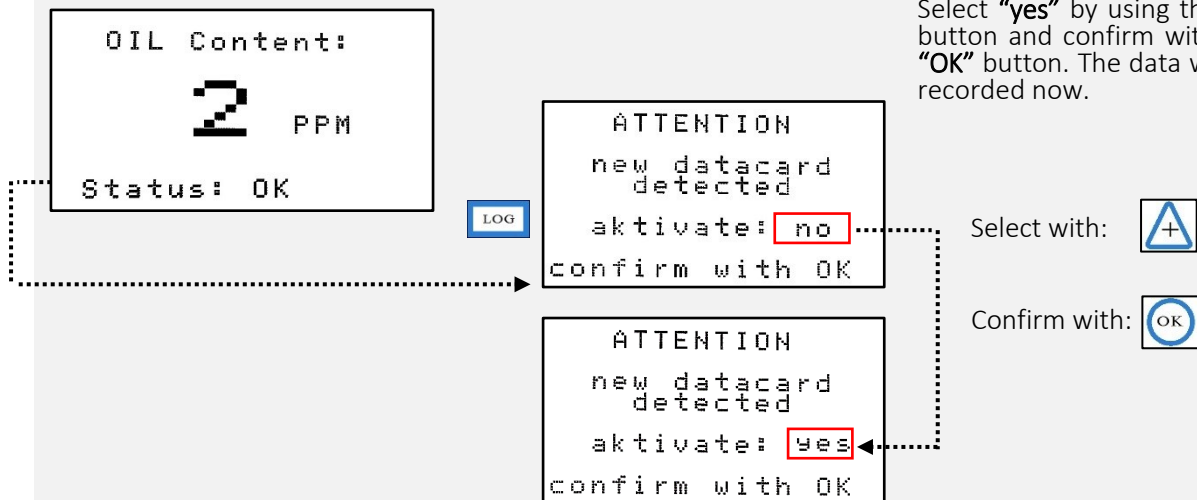



23.5 Software additional information

This OMD-24 EV AA Unit is applied with a special software to control the Autoclean System in connection with fresh water flush. All settings can be done on **“SYSTEM OPTIONS”** menu.

Condition 1: Setting the FW-Flush

FW Flush can be selected with the FW flush entry. It can be set to **“off”**, **“on”**, and **“Autoclean”** which enables that FW flush is started by the Autoclean timer in case of cleaning the glass-tube automatically.

Timing:

If FW flush is set to **“on”** the FW-Valve switches to FW-input instantaneously and switch back to **“Sample-Input”** after 2 minutes autonomous, either if FW flush is set to **“Autoclean”** the FW-Valve switches to FW condition 2 seconds before a cleaning cycle is started by the Autoclean - Timer (**“AUTOCLEAN”**). After cleaning with cleaning piston, the system allows flush with freshwater another 10 seconds more before switch back to **“Sample”** input. In any case, setting the FW Valve to FW-input set system in **“alarm”**- condition.

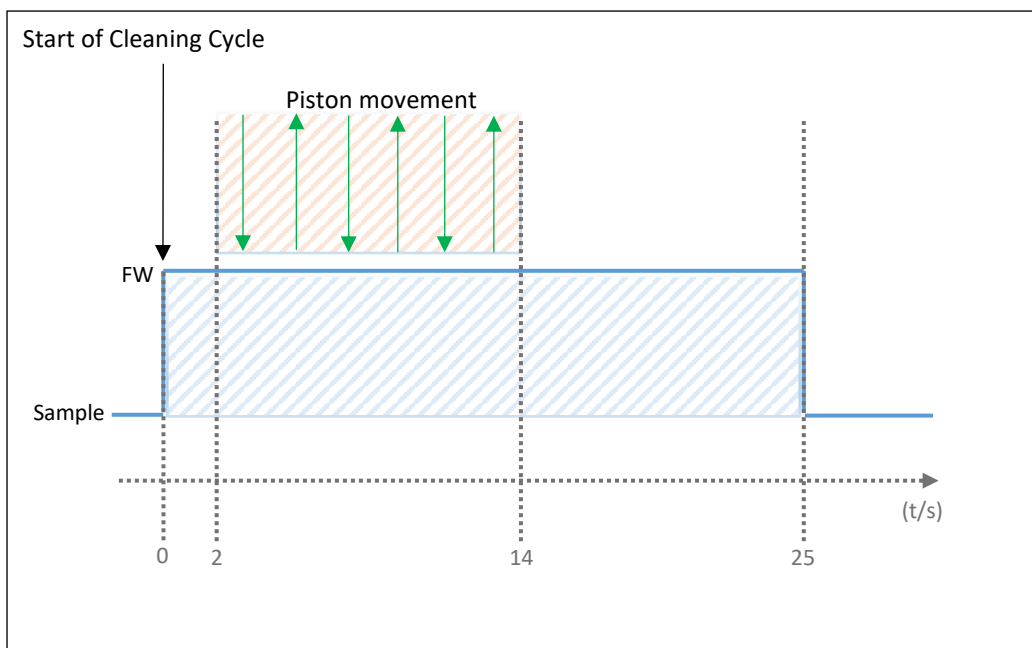
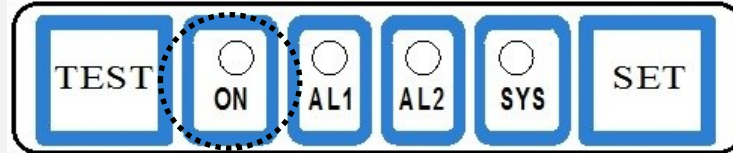

Figure 33 Start of Cleaning Cycle



FW FLUSH - AUTOCLEAN



Selecting the "ON" button directly leads into the "SYSTEM-OPTIONS" menu.

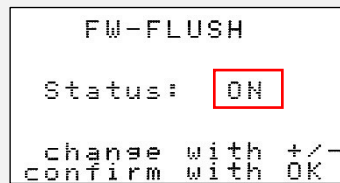
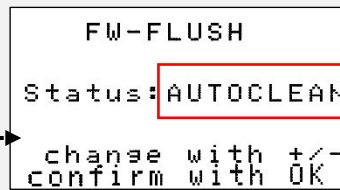
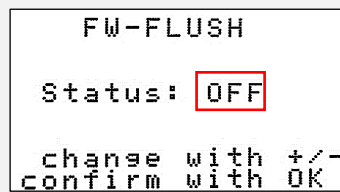
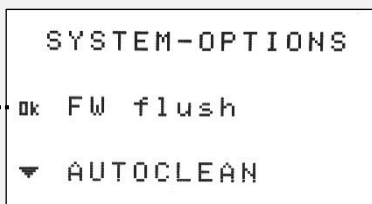

Select "ON" by using the "+" button and confirm with the "OK" button. Select "OFF" by using the "-" button and confirm with "OK" button.

Select with:  or 

Confirm with: 



Condition 2: Setting the Autoclean-System

The Autoclean interval can be set to several cleaning intervals. It is possible to set the time delay setting for Autoclean operation from minimum 1 min. to maximum 8 hours. Moreover, it is also possible to set the Autoclean system to **"FWdriven"**. That starts a cleaning cycle, whenever the unit is set to FW condition.

Timing:

About 2 seconds after switching FW-Valve to FW-input by software (see FW Flush **"ON"**) or externally (short terminals 19/20) a cleaning cycle is started automatically.

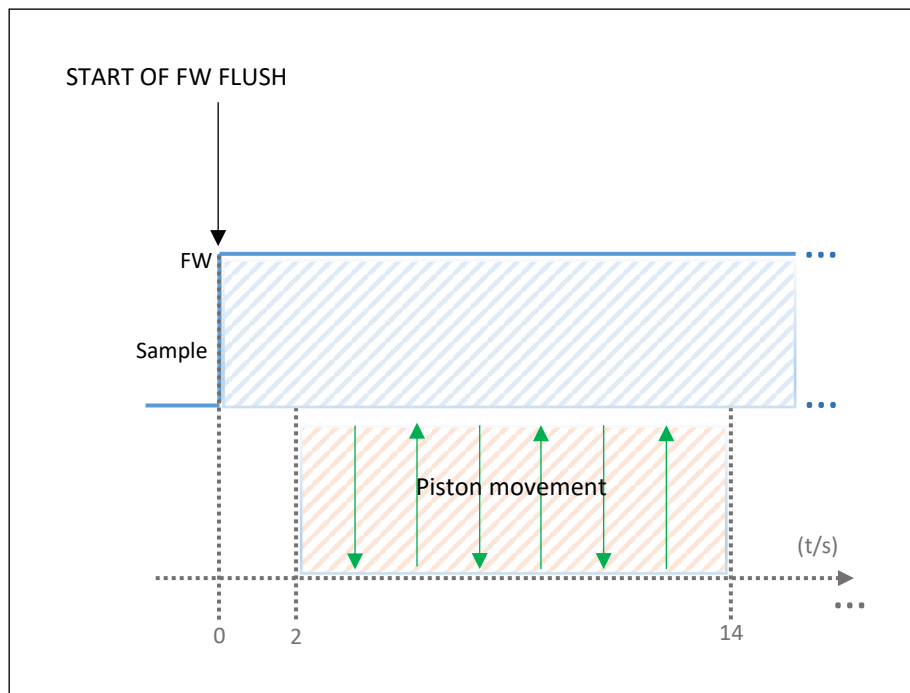
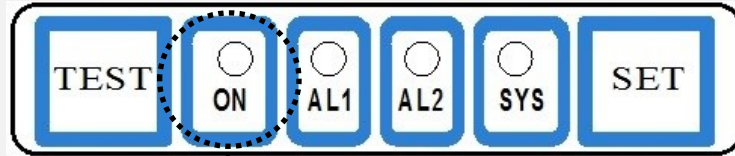

Figure 34 Start of FW FLUSH



FW FLUSH ON



Selecting the "ON" button directly leads into the "SYSTEM-OPTIONS" menu.

```
SYSTEM-OPTIONS
ok FW flush
▼ AUTOCLEAN
```

```
CLEAN INTERVAL
min.: off
max.→ off
next: 8h
def.: 3h57'41"
confirm with OK
```

```
CLEAN INTERVAL
min.: off
max.→ FWdriver
next: 0h00'51
confirm with OK
```

```
CLEAN INTERVAL
min.: off
max.→ 4h
next: 3h57'41"
def.: 2h
confirm with OK
```

Pressing the "-" button leads into the "CLEAN INTERVAL" display.

In this display status it is possible to check and set the time delay setting for Autoclean operation from minimum **1 min.** to maximum **8 hours**. Alternatively, it is possible to switch **off** the Autoclean completely or set the Autoclean in connection with FW to **FWdriver** (see above Autoclean Instruction).

Less than 2 hours can lead to mechanical wear and decreased lifetime.

Line "next" displays the remaining time towards the next cleaning cycle. This is especially useful, if remaining very long (several hours) cleaning intervals.

By pushing the "SET" button, the time will be reset default times "def." 2 hours will be adopted.

Select the required point by using the "+" or "-" button and confirm with "OK" button.

The Autoclean interval should be "off" or "FWdriver", if it is uncertain, that a sample stream is maintained. If the cleaner operates in a dry Sample Glass Tube, increased wear is to be expected.



24. Appendix III.

24.1 ALARMS

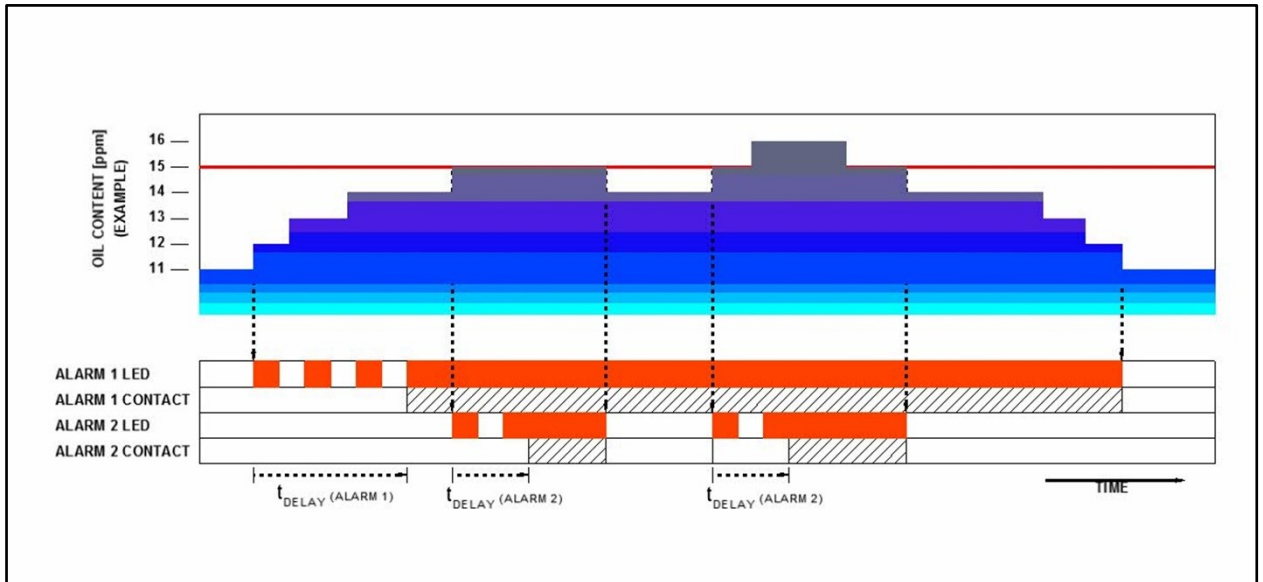

Figure 35. Alarms Example

The figure above reflects how the two independent alarms are working. In this example alarm 1 is set to 12 ppm and alarm 2 is set to 15 ppm. Each alarm is set to an individual delay setting.

Once the oil content is higher than 12 ppm, alarm 1 LED will blink red until the alarm 1 delay is exceeded. Then the alarm 1 contact will be in operation and alarm 1 LED will be continuously red as long as the measurement is higher than 12 ppm. Once the measurement is below 12 ppm, the alarm 1 contact will be out of operation and alarm 1 LED will be off.

Once the oil content is higher than 15 ppm, alarm 2 LED will blink red as long as alarm 2 delay is exceeded. Then alarm 2 contact will be in operation and alarm 2 LED will be continuously red, as long as the measurement is higher than 15 ppm. Once the measurement is below 15 ppm, alarm 2 contact will be out of operation and alarm 2 LED will be off.



25. Appendix IV.

25.1 Operator Maintenance Quick Checklist

Quick Checklist	yes	no	partly	value
1. Check the outward appearance for leakages.				
2. Check out the cables for wear.				
3. The desiccator humidity [%rH]:				
4. Switch the stream.				
5. Flush the Measuring Cell with clean water.				
6. Display shows 0 to 2 ppm. If not, follow up with the steps 8- 15.				
7. Stop any water flow. <i>(Shut off the instrument air.)</i>				
8. Check the O-Rings for wear.				
9. Check the wiper piston.				
10. Clean the Glass Tube.				
11. Screw back Cell Cap, MCU, or Auto Clean tight in.				
12. Flush the Measuring Cell with oil free water.				
13. Display shows 0 to 2 ppm. If not, use the Servicing and Cleaning Appendix.				
14. Check air pipe connection of air supply.				
15. Turn on the sample water flow.				
16. Perform a "System Test" for checking alarms.				
17. Check data logger/ clock.				
Checked by:	Date:		Signature:	



DECKMA
HAMBURG

26. Appendix V

26.1 Servicing and Cleaning Manual

To accomplish the cleaning process, please use the Servicing and Cleaning Manual.



DECKMA
HAMBURG

SERVICING AND CLEANING MANUAL

OMD-SERIES

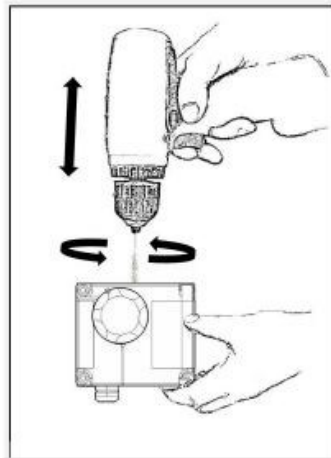

Cleaning Procedure of Measuring Cell MZ-09

- Cleaning Manually
- Cleaning Mechanically Assisted
- Cleaning of Iron Oxide and Calcification

We help to protect the Environment



DECKMA
HAMBURG



DECKMA
HAMBURG

Appendix V.

Content

Revision..... 2
 Symbols 3
 1. Measuring Cell Cleaning 4
 1.1 Cleaning Manually..... 4
 1.2 Cleaning with Sample Tube Cleaner 6
 1.3 Cleaning Mechanically Assisted 7
 1.4 Cleaning of Iron Oxide and Calcification 9
 1.5 Outward Appearance..... 10
 1.6 Checking the O-Rings 11
 1.7 Desiccator Check..... 13
 Servicing Worldwide 14
 Notes:..... 15

Revision

Document-Name	Revision No.	Notation	Date
Servicing and Cleaning Manual OMD-Series	R01_20170316		16.03.2017



DECKMA
HAMBURG



DECKMA
HAMBURG

Usage of the Service Manual

This Service Manual will guide you how to clean a Measuring Cell onboard. The instruction manual is split into sections. Every section handles a specific type of cleaning. The first part gives you general information about the outward appearance before cleaning and servicing the Measuring Cell.

The included information should be used only by a technician or a system operator for keeping the units correctly set up and cater for a clean Measuring Cell.

Following this Service Manual ensures clean maintenance and allows a right handling of the instrument

This instruction manual contains also information about the service support and our contact details. Additionally, the symbols below will support you during the cleaning process.

Symbols

- ✓ This symbol is used to show the right handling.
- X This symbol is used to show what to avoid.
- ⚙ This symbol is used for giving advices about servicing.
- ➔ This symbol is used for giving general advices.
- ⚠ This symbol is used to show warning of eye irritation and skin irritation.



1. Measuring Cell Cleaning

1.1 Cleaning Manually

Step 1.

Stop any water flow.

Step 2.

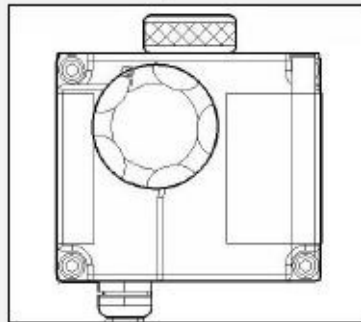

Figure 1

Unscrew Cell Cap, MCU, or Autoclean.

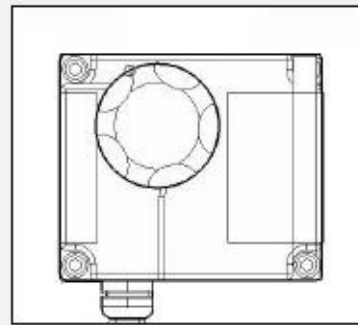

Figure 2

Remove Cell Cap, MCU, or Autoclean.

Step 3.

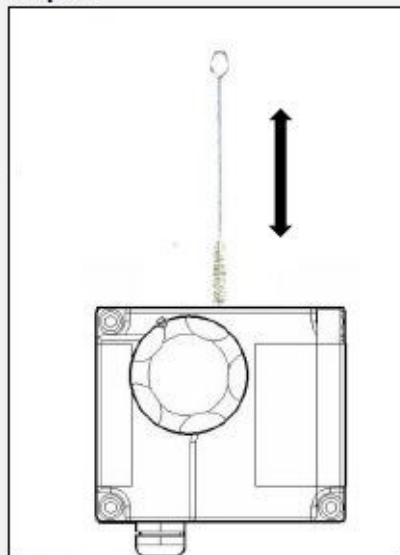

Figure 3

1. For cleaning the Sample Glass Tube, use the Cell Cleaning Brush with upwards and downwards motion through the Measuring Cell several times. Use some water to wet the Cell Cleaning Brush.
2. Remove the Cell Cleaning Brush and replace the Cell Cap.
3. Switch clean water valve to fresh water and allow oil free water to flow through the instrument for few minutes.
4. Avoid air bubbles in the stream.
5. Verify, that the display shows 0 to 2 ppm.
6. Cleaning has been sufficient if display shows 0 to 2 ppm.



DECKMA
HAMBURG



DECKMA
HAMBURG

Step 4.

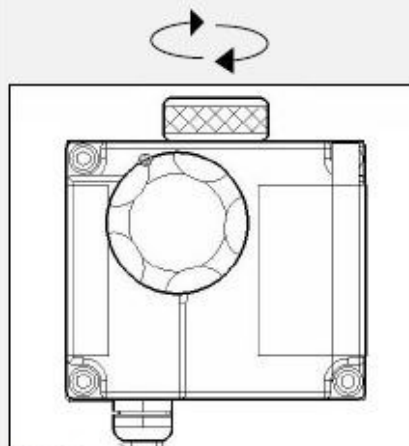

Figure 4

1. Screw in the Cell Cap.
2. Check, that the Measuring Cell Cap is screwed down completely.

Appendix V.



1.2 Cleaning with Sample Tube Cleaner

Step 1.



Figure 5

For intensive cleaning use the Sample Tube Cleaner from the Service Kit (Order No.: 18570). Apply clean Sample Tube Cleaner to the Cell Cleaning Brush and add water.

Step 2.

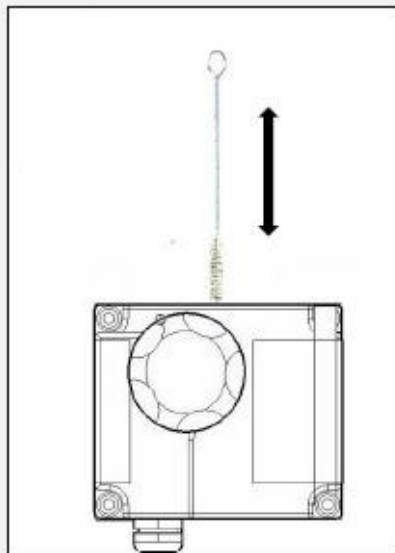

Figure 6

Clean the Sample Glass Tube with the Cell Cleaning Brush by applying the Sample Tube Cleaner.

1. For cleaning the Sample Glass Tube, use the Cell Cleaning Brush with upwards and downwards motion through the Measuring Cell several times. Wet the Cell Cleaning Brush.
2. Remove the Cell Cleaning Brush and replace the Cell Cap.
3. Switch clean water valve to fresh water and allow oil free water to flow through the instrument for few minutes.
4. Observe, that the display shows 0 to 2 ppm.

➔ Check, that the Measuring Cell Cap is screwed down completely.



1.3 Cleaning Mechanically Assisted

Step 1.

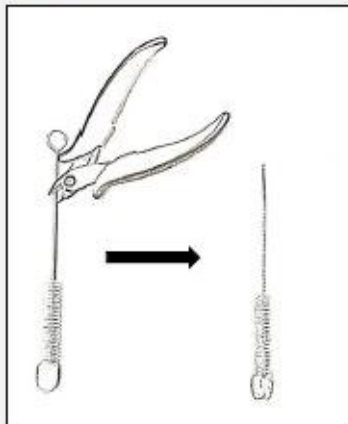

Figure 7

If the manual cleansing was not successful, an additional cleaning is recommended.

1. Cut the upper part of the Cell Cleaning Brush.
2. Insert the wire stem of the Cell Cleaning Brush into a screwdriver and fix it.
3. Slowly rotate the Cell Cleaning Brush for a few minutes in the Sample Glass Tube (See Step 3.)
4. Flush with clean water and re-test.

Step 2.

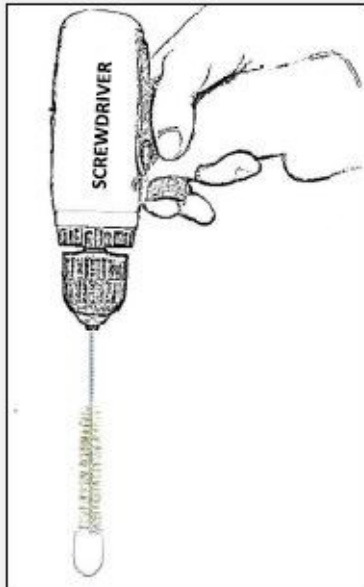

Figure 8

➔ You can also use some Sample Tube Cleaner. It does not damage the surface of the Sample Glass Tube. Please do not use other abrasive cleaners, hard particles contained may damage the Sample Glass Tube within seconds.



DECKMA
HAMBURG



DECKMA
HAMBURG

Appendix V.

Step 3.

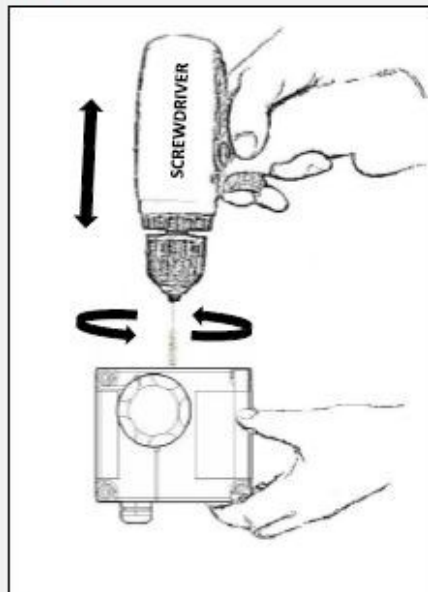

Figure 9

Use a screwdriver for an efficient cleaning. Slowly strike the Cell Cleaning Brush in the Measuring Cell for a few minutes and flush with clean water.

→ Check, that the Measuring Cell Cap is screwed down completely!



1.4 Cleaning of Iron Oxide and Calcification

Step 1.

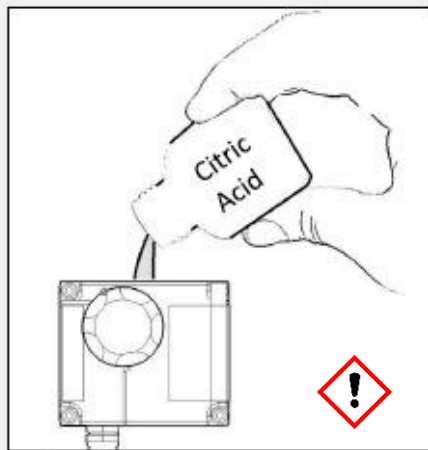

Figure 10

To clean Iron Oxide deposit, calcification, and other stubborn deposit, it is recommended to use the Citric Acid from the Service Kit (Order No.: 18570).

1. Ensure that the valves remain closed.
2. Mix some Citric Acid with 15 ml water.
3. Fill the Sample Glass Tube with the Citric Acid liquid and let it soak over night.
4. Flush with clean water without gas.



1.5 Outward Appearance

Step 1.

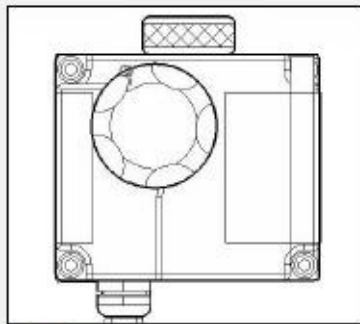

Figure 11

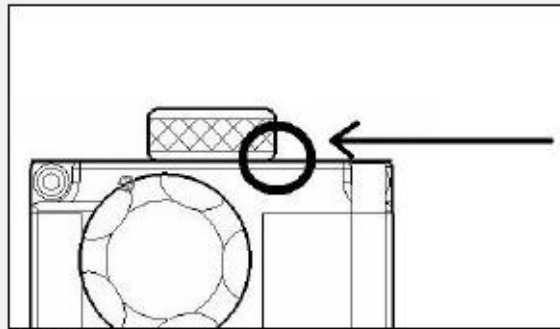

Figure 12

Check, that Cell Cap, MCU, or Autoclean is screwed down completely.

X

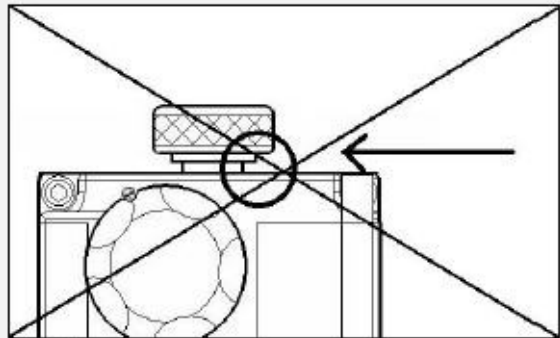

Figure 13

A not completely screwed down Cell Cap may allow formation of air bubbles and may influence with flow rate settings.



1.6 Checking the O-Rings

Step 1.

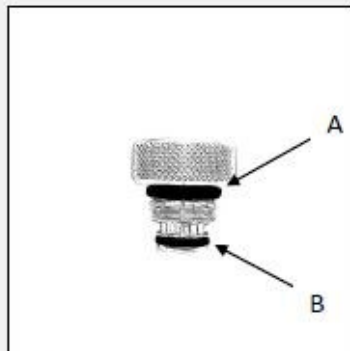

Figure 14

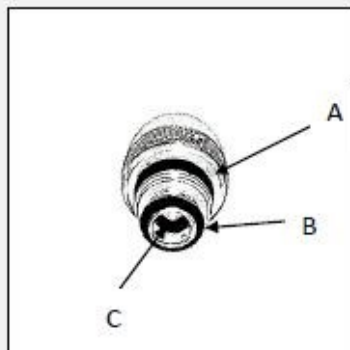

Figure 15

1. Check the condition of the three O-Rings as shown in the figures. If damaged, replace.
2. O-Rings B + C may or may not be present, depending on flow rate adjustment.
3. O-Ring A is always present.

A=11.5X3 mm

B= 8.5X2 mm

C= 4.5X2 mm

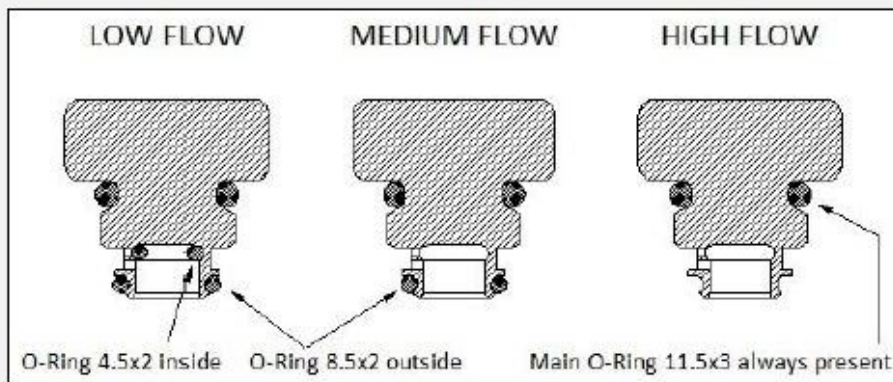

Figure 16



DECKMA
HAMBURG



DECKMA
HAMBURG

Appendix V.

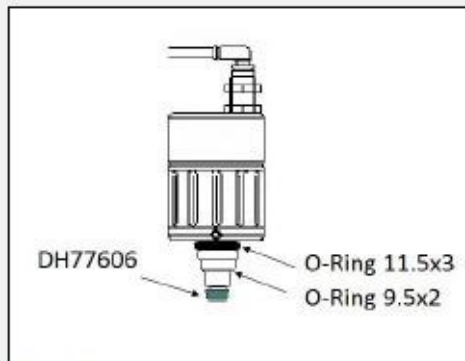

Figure 17

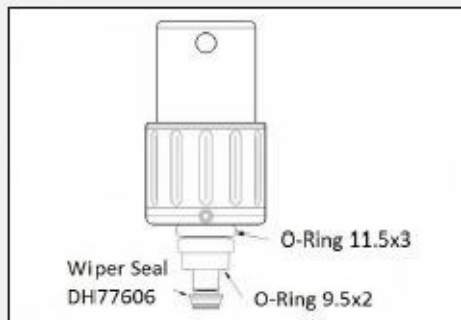

Figure 18



Figure 19

For Units equipped with MCU/ Automatic Cell Cleaning Device, check the two O-Rings and the piston seal.



1.7 Desiccator Check

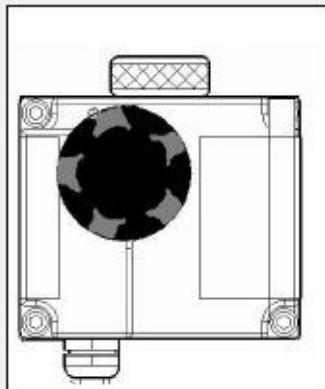

Figure 20

1. Press "SYS" Button, select Measuring Cell, confirm.
2. Internal data will be displayed.
3. The relative humidity [%rH] should be below 10%rH.
4. The dew-point Temperature should be below 0° C.
5. If not, exchange desiccator.
6. The desiccator also has to be exchanged, if humidity is higher 40%rH.

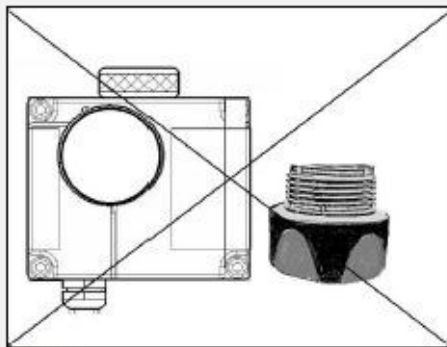

Figure 21



Do not expose the Desiccator to ambient air. Do not leave the Desiccator opening uncovered.



Index:

A

Adjustment 13, 18, 24, 30, 36, 42, 58, 71
Air Regulation 15, 32, 33
Alarms 3, 9, 13, 62, 63, 71
Automatic Cell Cleaning Device 9, 15

C

Calibration 3, 12, 13, 63, 71
Card Reader 76
Cell Cap 15, 37, 48, 63
Certificate 71
Certification 63
Commissioning 53
Computer Unit 3, 19, 25, 30, 31, 36, 37, 38, 42
Construction 16

D

Data Logger Operation Buttons 65, 86
Desiccator 63

E

Electric Valve 16

F

Function Test Kit 76
Functional Button 13, 55, 56, 59, 60, 64, 65, 70, 79, 80,
82, 84

G

Glass Tube 15, 62, 63

H

Humidity 63

I

Installation 1, 3, 9, 11, 16, 32, 37, 51, 53

M

MCU 15, 16, 42, 48, 76
Measuring Cell 3, 11, 14, 38, 74
Memory Card 3, 66, 76, 86

N

Navigation Buttons 64, 78

O

Offset 13
Oil Content 58, 72
OMD-24 FC 41, 44
Operator Maintenance 60
Output 32, 50

P

Power Supply 13, 18, 24, 30, 36, 42, 49, 50, 51, 52, 53, 71

S

Sample 12, 15, 18, 19, 21, 24, 30, 36, 39, 42, 54, 55, 58,
59, 71, 72
Sensor-PCB 43, 47
Service Exchange Units 3
Servicing 1, 11, 53
Settings 16, 32, 64
Spare Parts 74
Specification 18, 24, 30, 36, 42, 71

W

Warranty 3
Wiring 53



List of Figures

Figure 1 Touch Panel	12
Figure 2. Construction OMD-24.....	19
Figure 3. Installation OMD-24	20
Figure 4. Piping OMD-24	21
Figure 5. Bottom View: OMD-24	22
Figure 6. Construction OMD-24 EV	25
Figure 7. Installation OMD-24 EV	26
Figure 8. Piping OMD-24 EV	27
Figure 9. Bottom View: OMD-24 EV	28
Figure 10. Construction OMD-24 EVA	31
Figure 11. Installation OMD-24 EVA.....	32
Figure 12. Piping OMD-24 EVA.....	33
Figure 13. Bottom View: OMD-24 EVA.....	34
Figure 14. Construction OMD-24 A	37
Figure 15. Installation OMD-24 A	38
Figure 16 Piping OMD-24 A	39
Figure 17. Bottom View: OMD-24 A	40
Figure 18 OMD-24 FC	43
Figure 19. Automatic Cell Cleaning Device, pneumatically operated	48
Figure 20. MCU DH77780 Manual Cell Cleaning Unit, manually operated	48
Figure 21. Connection Example.....	49
Figure 22. "Initializing Display".....	54
Figure 23. "Normal Operation" Display.....	54
Figure 24. Flow Rate Adjustment Cell Cap	55
Figure 25. Flow Rate Adjustment Automatic Cell Cleaning Device/ MCU	55
Figure 26. Auto Clean Control Unit.....	56
Figure 27 Pressure Regulation.....	57
Figure 28 Using standard drainage.....	57
Figure 29. Operating Instructions OMD-24	58
Figure 30. Display Functions.....	64
Figure 31. Memory Card Location	66
Figure 32. OMD-CR Memory Card Reader	67
Figure 33 Start of Cleaning Cycle.....	87
Figure 34 Start of FW FLUSH	89
Figure 35. Alarms Example	91



DECKMA
HAMBURG



Sales & Service Locations

DECKMA HAMBURG GMBH

Kieler Strasse 316
22525 Hamburg
Germany

Tel.: +49 (0)40 548876-0
Fax : +49 (0)40 548876-10
eMail : post@deckma.com
Internet : <http://www.deckma.com/>

General Inquiries: post@deckma.com

Service Inquiries: service@deckma.com

Global Sales & Service Locations & Contacts listed on our Website:

<http://www.deckma.com/agents>



DECKMA
HAMBURG

Type Approved by:



Dienststelle Schiffssicherheit
BG Verkehr

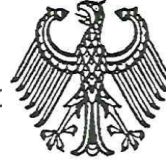

Europäisch notifizierte Stelle
Kennnummer 0736
European notified body
Identification number 0736



CCS
CHINA CLASSIFICATION SOCIETY
中国船级社



Canada



DECKMA
HAMBURG

DECKMA HAMBURG GmbH Kieler Straße 316, D-22525 Hamburg

Tel.: +49 (0) 40 54 88 76-0
Fax: +49 (0) 40 54 88 76-10
Internet: www.deckma.com
E-Mail: post@deckma.com

