

Operating Instructions

Single channel controller for level detection for 8/16 mA sensors

VEGATOR 121



Document ID: 57662



VEGA

Contents

1	About this document	4
1.1	Function	4
1.2	Target group	4
1.3	Symbols used	4
2	For your safety	5
2.1	Authorised personnel	5
2.2	Appropriate use	5
2.3	Warning about incorrect use	5
2.4	General safety instructions	5
2.5	Installation and operation in the USA and Canada	5
2.6	Safety instructions for Ex areas	6
3	Product description	7
3.1	Configuration	7
3.2	Principle of operation	7
3.3	Adjustment	8
3.4	Packaging, transport and storage	8
4	Mounting	9
4.1	General instructions	9
5	Connecting to power supply	10
5.1	Preparing the connection	10
5.2	Connection procedure	11
5.3	Wiring plan	11
6	Setup	13
6.1	Adjustment system	13
6.2	Adjustment elements	13
6.3	Automatic function test	15
6.4	Function table "Point level"	17
7	Diagnostics and servicing	19
7.1	Maintenance	19
7.2	Rectify faults	19
7.3	Diagnosis, fault messages	19
7.4	How to proceed if a repair is necessary	20
8	Dismount	22
8.1	Dismounting steps	22
8.2	Disposal	22
9	Certificates and approvals	23
9.1	Approvals for Ex areas	23
9.2	EU conformity	23
9.3	SIL conformity (optional)	23
9.4	Environment management system	23
10	Supplement	24
10.1	Technical data	24
10.2	Dimensions	26
10.3	Industrial property rights	27

10.4 Trademark 27

Supplementary documentation



Information:

Supplementary documents appropriate to the ordered version come with the delivery. You can find them listed in chapter " *Product description*".

Editing status: 2021-07-12

1 About this document

1.1 Function

This instruction provides all the information you need for mounting, connection and setup as well as important instructions for maintenance, fault rectification, the exchange of parts and the safety of the user. Please read this information before putting the instrument into operation and keep this manual accessible in the immediate vicinity of the device.

1.2 Target group

This operating instructions manual is directed to trained personnel. The contents of this manual must be made available to the qualified personnel and implemented.

1.3 Symbols used



Document ID

This symbol on the front page of this instruction refers to the Document ID. By entering the Document ID on www.vega.com you will reach the document download.



Information, note, tip: This symbol indicates helpful additional information and tips for successful work.



Note: This symbol indicates notes to prevent failures, malfunctions, damage to devices or plants.



Caution: Non-observance of the information marked with this symbol may result in personal injury.



Warning: Non-observance of the information marked with this symbol may result in serious or fatal personal injury.



Danger: Non-observance of the information marked with this symbol results in serious or fatal personal injury.



Ex applications

This symbol indicates special instructions for Ex applications.



List

The dot set in front indicates a list with no implied sequence.



Sequence of actions

Numbers set in front indicate successive steps in a procedure.



Battery disposal

This symbol indicates special information about the disposal of batteries and accumulators.

2 For your safety

2.1 Authorised personnel

All operations described in this documentation must be carried out only by trained, qualified personnel authorised by the plant operator.

During work on and with the device, the required personal protective equipment must always be worn.

2.2 Appropriate use

VEGATOR 121 is a universal controller for connection of level switches.

You can find detailed information about the area of application in chapter " *Product description*".

Operational reliability is ensured only if the instrument is properly used according to the specifications in the operating instructions manual as well as possible supplementary instructions.

2.3 Warning about incorrect use

Inappropriate or incorrect use of this product can give rise to application-specific hazards, e.g. vessel overfill through incorrect mounting or adjustment. Damage to property and persons or environmental contamination can result. Also, the protective characteristics of the instrument can be impaired.

2.4 General safety instructions

This is a state-of-the-art instrument complying with all prevailing regulations and directives. The instrument must only be operated in a technically flawless and reliable condition. The operator is responsible for the trouble-free operation of the instrument. When measuring aggressive or corrosive media that can cause a dangerous situation if the instrument malfunctions, the operator has to implement suitable measures to make sure the instrument is functioning properly.

The safety instructions in this operating instructions manual, the national installation standards as well as the valid safety regulations and accident prevention rules must be observed by the user.

For safety and warranty reasons, any invasive work on the device beyond that described in the operating instructions manual may be carried out only by personnel authorised by the manufacturer. Arbitrary conversions or modifications are explicitly forbidden. For safety reasons, only the accessory specified by the manufacturer must be used.

To avoid any danger, the safety approval markings and safety tips on the device must also be observed.

2.5 Installation and operation in the USA and Canada

This information is only valid for USA and Canada. Hence the following text is only available in the English language.

Installations in the US shall comply with the relevant requirements of the National Electrical Code (ANSI/NFPA 70).

Installations in Canada shall comply with the relevant requirements of the Canadian Electrical Code.

2.6 Safety instructions for Ex areas

For applications in explosion-proof areas (Ex), only devices with corresponding Ex approval may be used. Observe the Ex-specific safety instructions. These are an integral part of the operating instructions and are enclosed with every device with Ex approval.

3 Product description

3.1 Configuration

Scope of delivery

The scope of delivery encompasses:

- Controller VEGATOR 121
- Documentation
 - This operating instructions manual
 - Ex-specific "*Safety instructions*" (with Ex version)
 - Safety Manual "Functional safety (SIL) acc. to IEC 61508" (with SIL version)
 - If necessary, further certificates

Type label

The type label contains the most important data for identification and use of the instrument:

- Instrument type
- Information about approvals
- Technical data
- Serial number of the instrument
- QR code for device documentation
- Manufacturer information

Documents and software

Move to "www.vega.com" and enter in the search field the serial number of your instrument.

There you can find the following information about the instrument:

- Order data
- Documentation
- Software

Alternatively, you can find all via your smartphone:

- Scan the QR-code on the type label of the device or
- Enter serial number manually in the VEGA Tools app (available free of charge in the respective stores)

3.2 Principle of operation

Application area

The VEGATOR 121 is a single channel controller for level detection of limit switches with 8/16 mA interface. Via the integrated relay simple control tasks can be solved. Typical applications are monitoring functions such as overflow or dry run protection, Optionally an additional second relay can be ordered. Via a DIL switch the function of the second relay can be determined. It can be configured as fail safe relay or as second level relay.

Functional principle

The VEGATOR 121 controller powers connected sensors and simultaneously processes their measuring signals.

When the medium reaches the switching point of the sensor, the sensor current changes. This is measured and evaluated by VEGATOR 121. The change causes the output relays to switch according to the set operating mode.

3.3 Adjustment

All adjustment elements are located under a hinged front plate. The operating mode, switch-on pulse monitoring and the switching delay can be set via a DIL switch block. In addition, the correct function of the measuring system can be checked by simply pressing a key.

3.4 Packaging, transport and storage

Packaging

Your instrument was protected by packaging during transport. Its capacity to handle normal loads during transport is assured by a test based on ISO 4180.

The packaging of standard instruments consists of environment-friendly, recyclable cardboard. For special versions, PE foam or PE foil is also used. Dispose of the packaging material via specialised recycling companies.

Transport

Transport must be carried out in due consideration of the notes on the transport packaging. Nonobservance of these instructions can cause damage to the device.

Transport inspection

The delivery must be checked for completeness and possible transit damage immediately at receipt. Ascertained transit damage or concealed defects must be appropriately dealt with.

Storage

Up to the time of installation, the packages must be left closed and stored according to the orientation and storage markings on the outside.

Unless otherwise indicated, the packages must be stored only under the following conditions:

- Not in the open
 - Dry and dust free
 - Not exposed to corrosive media
 - Protected against solar radiation
 - Avoiding mechanical shock and vibration
- Storage and transport temperature see chapter " *Supplement - Technical data - Ambient conditions*"
 - Relative humidity 20 ... 85 %

Storage and transport temperature

4 Mounting

Mounting options

4.1 General instructions

VEGATOR 121 is designed for carrier rail mounting (top hat rail 35 x 7.5 according to DIN EN 50022/60715). Due to its protection rating of IP20, the instrument is suitable for mounting in switching cabinets. It can be mounted horizontally and vertically.

**Note:**

When several instruments are mounted together without space in between, the ambient temperature at the installation location of the instrument must not exceed 60 °C. Around the ventilation slots there must be a distance of at least 2 cm to the next component.



VEGATOR 121 in Ex version is a corresponding, intrinsically safe instrument and must not be installed in hazardous areas. A safe operation is only ensured if the operating instructions and EU type approval certificate are observed. VEGATOR 121 must not be opened.

A distance of 50 mm to the intrinsically safe terminals must be ensured when mounting.

Ambient conditions

The instrument is suitable for standard and extended ambient conditions acc. to DIN/EN/IEC/ANSI/ISA/UL/CSA 61010-1.

Make sure that the environmental and ambient conditions specified in chapter " *Technical data*" are maintained.

5 Connecting to power supply

5.1 Preparing the connection

Safety instructions

Always keep in mind the following safety instructions:



Warning:

Connect only in the complete absence of line voltage.

- Connect only in the complete absence of line voltage
- If overvoltage surges are expected, overvoltage arresters should be installed



Note:

Install a disconnecting device for the instrument which is easy to access. The disconnecting device must be marked for the instrument (IEC/EN 61010).

Safety instructions for Ex applications



In hazardous areas you must take note of the respective regulations, conformity and type approval certificates of the sensors and power supply units.

Voltage supply

The data for power supply are specified in chapter " *Technical data*".

Connection cable

The voltage supply of VEGATOR 121 is connected with standard cable according to the national installation standards.

The sensors are connected with standard two-wire cable without shielding. If electromagnetic interference is expected which is above the test values of EN 61326 for industrial areas, shielded cable should be used.

Make sure that the cable used has the required temperature resistance and fire safety for max. occurring ambient temperature

Cable screening and grounding

Connect the cable shielding on both ends to ground potential. In the sensor, the shielding must be connected directly to the internal ground terminal. The ground terminal on the outside of the sensor housing must be connected to the potential equalisation (low impedance).

If potential equalisation currents are expected, the connection on the processing side must be made via a ceramic capacitor (e. g. 1 nF, 1500 V). The low-frequency potential equalisation currents are thus suppressed, but the protective effect against high frequency interference signals remains.

Connection cable for Ex applications



Take note of the corresponding installation regulations for Ex applications. In particular, make sure that no potential equalisation currents flow over the cable screen. In case of grounding on both sides this can be achieved by the use of a capacitor or a separate potential equalisation.

5.2 Connection procedure

The pluggable terminals can be removed as needed to allow more convenient connection. To make the electrical connection, proceed as follows:

1. Mount the instrument as described in the previous chapter
2. Connect sensor cable to terminal 1/2, and where applicable, connect the shielding
3. Connect switched-off power supply to terminal 16/17
4. Connect relay to terminal 10/11/12
5. Option with fail safe relay: Connect relay to terminal 13/14/15

The electrical connection is finished.

5.3 Wiring plan

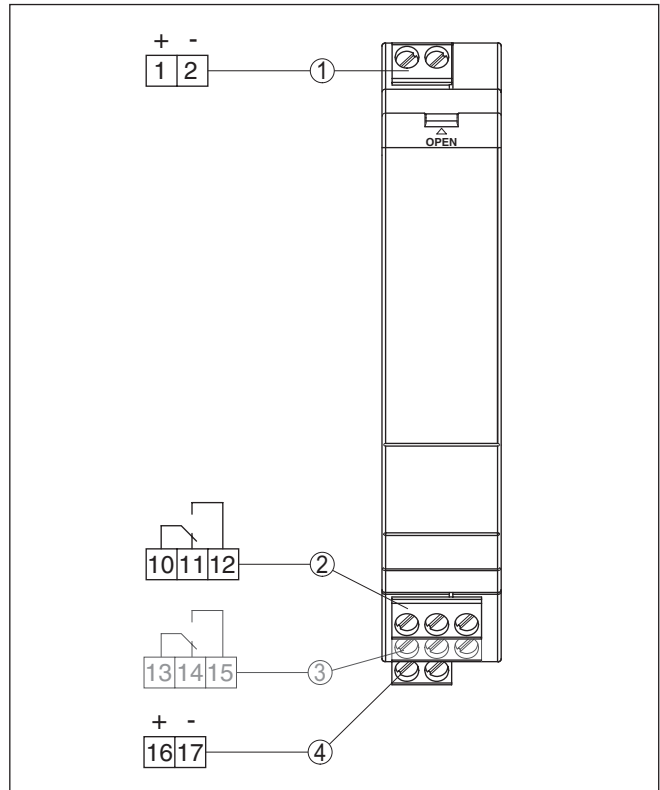

- 1 Sensor circuit (8/16 mA)
- 2 Relay output
- 3 Fail safe relay/second relay output (optional)
- 4 Voltage supply



Information:

The connection terminals can be detached towards the front, if necessary. This can be useful when working in tight spaces or for exchange of an instrument.

6 Setup

6.1 Adjustment system

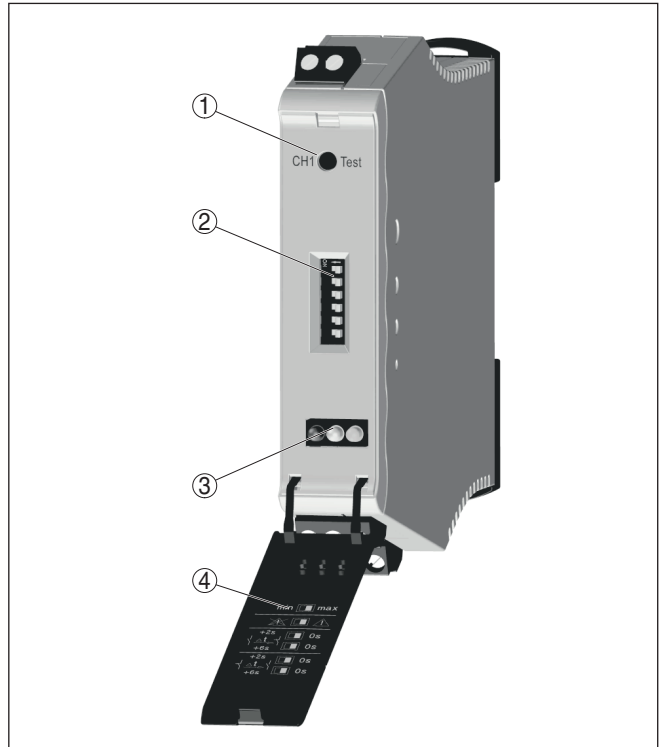

Fig. 1: Display and adjustment elements

- 1 Test key
- 2 DIL switch block
- 3 Signal lamps (LEDs)
- 4 Hinged front cover

6.2 Adjustment elements

Control lamps

Control lamps (LED) in the front plate indicate operation, switching status and fault signal.

- Green
 - Operating control lamp
 - Mains voltage on, instrument is operating
- Red
 - Fault indicator
 - Fault on the sensor circuit due to sensor failure or line break
 - The relay deenergises in case of failure
- Yellow

- Relay control lamp
- Lights with activated (current-carrying) relay status

Front cover

The adjustment elements are located under a hinged front cover. To open it, use a small screwdriver in conjunction with the slot on the upper side of the front cover. To close it, push the cover at bottom and top firmly onto the front cover until you hear the two retaining clips snap in.

DIL switch block

The DIL switch block is located behind the front cover. The individual switches are assigned as follows:

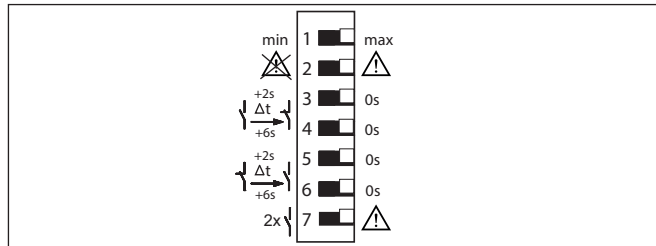

Fig. 2: DIL switch VEGATOR 121

- 1 Mode (min./max. adjustment)
- 2 Switch-on pulse monitoring On/Off
- 3 Switch-on delay 2 seconds
- 4 Switch-on delay 6 seconds
- 5 Switch-off delay 2 seconds
- 6 Switch-off delay 6 seconds
- 7 Switchover, function relay 2 (optional)

Mode (min./max. adjustment)

The requested operating mode is set with the min./max. switch (min. detection i.e. dry run protection or max. detection i.e. overflow protection)

- **Dry run protection:** Relay is switched off when the level falls below the min. level (safe currentless state), relay is switched on again when the min. level is exceeded (switch-on point > switch-off point)
- **Overflow protection:** Relay is switched off when the max. level is exceeded (safe currentless state), relay is switched on again when the level falls below the max. level (switch-on point < switch-off point)



Note:

If the connected sensor has an own mode switch, then this switch must be set to " **Max.** ".

Switch-on pulse monitoring

While switching on, the sensors VEGASWING, VEGAVIB, VEGA-WAVE deliver a defined switching sequence in which the switching conditions empty/full/failure are run through. This switching sequence is checked and evaluated when switch-on pulse monitoring is activated. If this does not correspond to the definition or is completely missing, the VEGATOR 121 displays a fault. A function test is only

triggered by pressing the test key. This function test is not carried out automatically when switching on the VEGATOR 121.



Note:

When connecting sensors without this defined switching sequence, the switch-on monitoring must be deactivated.

Switch-on/Switch-off delay

With these switches you can delay the changeover of the relays by the set time. This can be useful, e.g. with fluctuating product surfaces, for preventing unwanted switching commands. The switch-on/off delays can be set independently of each other. If both switches, e.g. of the switch-on delay, are activated, the times sum up. Delays of 2, 6 or 8 seconds can thus be adjusted.



Information:

Keep in mind that the switching delay of the sensor and controller accumulate.

Function relay 2 (optional)

A second relay can be ordered as an option for VEGATOR 121. The function of the second relay is determined via this DIL switch. It can be configured as fail safe relay or as second level relay. When configured as level relay, the switching behaviour is identical to relay 1. If the instrument is WHG approved, then both relays can be used as WHG relay.

Test key

When level switches VEGAVIB, VEGAWAVE, VEGASWING in two-wire version are connected, a function test can be carried out. The test key is recessed behind the front plate of the controller. Press the test key for at least one second with a suitable object (screwdriver, pen, etc.).



Note:

Keep in mind that downstream connected devices are activated during the function test. This allows you to check the correct function of the complete measuring system.

By pushing the test key, the circuit to the sensor is interrupted and a restart of the sensor is initiated. Through this, the conditions fault signal, empty and full alarm are simulated. The complete test procedure takes approx. 5 seconds. After correct function, the red failure LED should not light and depending on the status of the sensor, the relays are energized or deenergized.

If the test result is negative, the red failure LED lights up and the relays must be deenergized. In this case the whole measuring system has to be checked and repaired.



Information:

This test is accepted as proof test acc. to WHG.

6.3 Automatic function test

As an alternative to the manual test via test key, the function test can be also carried out automatically. For this purpose, the VEGATOR 121

with optional fail safe relay as well as a PLC are required. The following setup is necessary:

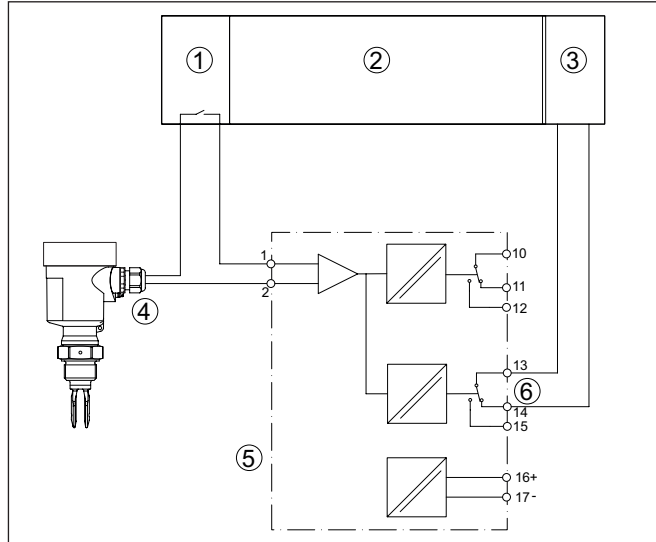

Fig. 3: Automated function test via fail safe relay and PLC

- 1 Digital PLC output
- 2 PLC
- 3 Digital PLC input
- 4 Sensor
- 5 VEGATOR 121
- 6 Fail safe relay

With the relay contact of the PLC output, the sensor current must be interrupted for at least 1 s. The switching-on impulse delivered by the sensor is controlled by VEGATOR 121. After a time of 6 s after switching on the sensor again, the result of the test will be available on the fail safe output and can be further processed by the PLC.

Switching-on impulse correct

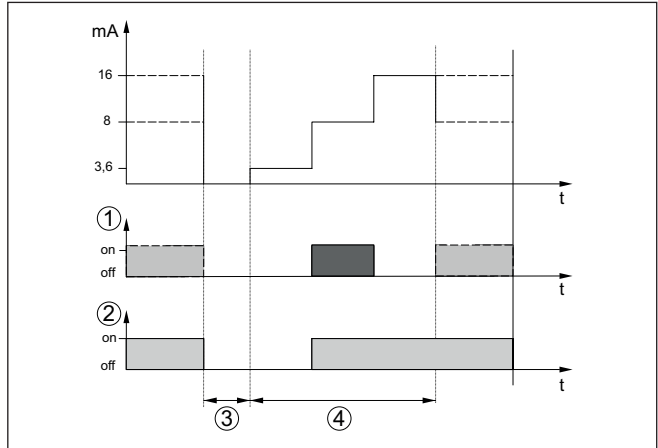

Fig. 4: Flow chart of a correct switching-on impulse

- 1 Level relay
- 2 Fail safe relay
- 3 Interruption of the sensor current for at least 1 s
- 4 Time until event is available (at least 6 s)

Switching-on impulse incorrect

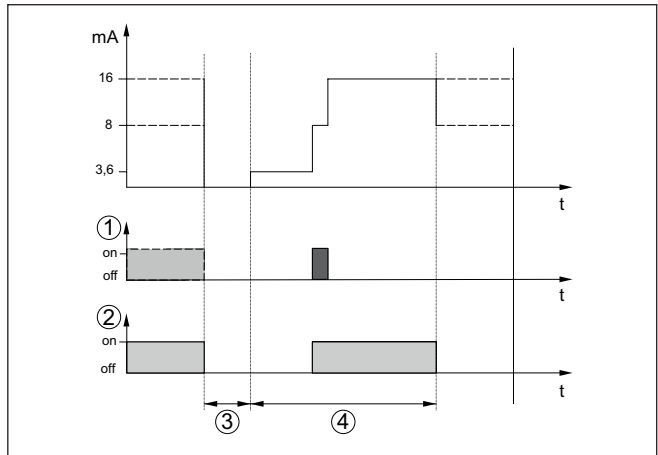

Fig. 5: Flow chart of an incorrect switching-on impulse

- 1 Level relay
- 2 Fail safe relay
- 3 Interruption of the sensor current for at least 1 s
- 4 Time until event is available (at least 6 s)









6.4 Function table "Point level"

The following table provides an overview of the switching conditions depending on the set mode and the level.









**Note:**

The switching conditions in the tables are only valid if the mode switch on the sensor is set to "Max.".

Overfill protection, point level

Sensor		Controller			
Level	Sensor current	LED yellow (output)	LED red (fault)	Relay	Fail safe relay (optional)
	approx. 8 mA			ON	ON
	approx. 16 mA			OFF	ON
any	< 3.6 mA > 21 mA			OFF	OFF

Dry run protection, point level

Sensor		Controller			
Level	Sensor current	LED yellow (output)	LED red (fault)	Relay	Fail safe relay (optional)
	approx. 16 mA			ON	ON
	approx. 8 mA			OFF	ON
any	< 3.6 mA > 21 mA			OFF	OFF

7 Diagnostics and servicing

7.1 Maintenance

Maintenance

If the device is used properly, no special maintenance is required in normal operation.

Cleaning

The cleaning helps that the type label and markings on the instrument are visible.

Take note of the following:

- Use only cleaning agents which do not corrode the housings, type label and seals
- Use only cleaning methods corresponding to the housing protection rating

7.2 Rectify faults

Reaction when malfunction occurs

The operator of the system is responsible for taking suitable measures to rectify faults.

Causes of malfunction

The device offers maximum reliability. Nevertheless, faults can occur during operation. These may be caused by the following, e.g.:

- Measured value from sensor not correct
- Voltage supply
- Interference in the cables

Fault rectification

The first measure to be taken is to check the input and output signals. The procedure is described as follows. In many cases the causes can be determined this way and faults can be easily rectified.

Reaction after fault rectification

Depending on the reason for the fault and the measures taken, the steps described in chapter " *Setup*" must be carried out again or must be checked for plausibility and completeness.

24 hour service hotline

Should these measures not be successful, please call in urgent cases the VEGA service hotline under the phone no. **+49 1805 858550**.

The hotline is also available outside normal working hours, seven days a week around the clock.

Since we offer this service worldwide, the support is provided in English. The service itself is free of charge, the only costs involved are the normal call charges.

7.3 Diagnosis, fault messages

Fault signal

The controller and the connected sensors are permanently monitored during operation. If irregularities occur, a fault signal is triggered. In the event of a failure, the fault indication lights up and the relays are de-energized (safe state).

Red fault LED lights up

Cause	Rectification
Sensor not connected correctly	<ul style="list-style-type: none"> ● In Ex systems, make sure that the Ex protection is not influenced by the measuring instruments used. ● Measure the current and voltage on the connection cable to the sensor ● Faults in the sensor causing a current change to below 3.6 mA or over 21 mA lead to a fault signal in the controllers. ● The terminal voltage must be inside the specified range. You can find this voltage range in the operating instructions of the connected sensor.
Sensor delivers no (correct) switch-on pulse	<ul style="list-style-type: none"> ● Use sensor with switching-on pulse ● Deactivate switch-on pulse monitoring
Sensor current < 3.6 mA	<ul style="list-style-type: none"> ● Check controller ● Check the terminal voltage on the controller; if it is < 17 V, the controller is defective -> exchange controller or return it for repair ● If the terminal voltage is > 17 V, disconnect the sensor cable at the controller and replace it with a 1 kΩ resistor. If the fault signal does not disappear, the controller is defective -> exchange controller or return it for repair ● Check sensor or sensor cable ● Reconnect the sensor cable to the controller, disconnect the sensor and replace it with a 1 kΩ resistor. If the fault signal does not disappear, then the sensor cable is broken -> replace the sensor cable ● If there is no longer a fault signal on the line, the sensor is defective -> exchange sensor or return it for repair
Sensor current > 21 mA	<ul style="list-style-type: none"> ● Check controller ● Disconnect sensor cable and replace it with a 1 kΩ resistor. If the fault signal does not disappear, the controller is defective -> exchange controller or return it for repair ● Check sensor or sensor cable ● Reconnect the sensor cable to the controller, disconnect the sensor and replace it with a 1 kΩ resistor. If the fault signal does not disappear, then the sensor cable is short-circuited -> eliminate the short-circuit or replace the sensor cable ● If there is no longer a fault signal on the line, the sensor is defective -> exchange sensor or return it for repair

7.4 How to proceed if a repair is necessary

You can find an instrument return form as well as detailed information about the procedure in the download area of our homepage. By doing this you help us carry out the repair quickly and without having to call back for needed information.

In case of repair, proceed as follows:

- Print and fill out one form per instrument
- Clean the instrument and pack it damage-proof
- Attach the completed form and, if need be, also a safety data sheet outside on the packaging
- Ask the agency serving you to get the address for the return shipment. You can find the agency on our homepage.

8 Dismount

8.1 Dismounting steps

Take note of chapters "*Mounting*" and "*Connecting to voltage supply*" and carry out the listed steps in reverse order.

8.2 Disposal

The device is made of recyclable materials. For this reason, it should be disposed of by a specialist recycling company. Observe the applicable national regulations.

9 Certificates and approvals

9.1 Approvals for Ex areas

Approved versions for use in hazardous areas are available or in preparation for the device series.

You can find the relevant documents on our homepage.

9.2 EU conformity

The device fulfils the legal requirements of the applicable EU directives. By affixing the CE marking, we confirm the conformity of the instrument with these directives.

The EU conformity declaration can be found on our homepage.

9.3 SIL conformity (optional)

Instruments with SIL option fulfill the requirements of functional safety according to IEC 61508. You can find further information in the supplied Safety Manual.

9.4 Environment management system

Protection of the environment is one of our most important duties. That is why we have introduced an environment management system with the goal of continuously improving company environmental protection. The environment management system is certified according to DIN EN ISO 14001. Please help us fulfil this obligation by observing the environmental instructions in chapters "*Packaging, transport and storage*", "*Disposal*" of these operating instructions.

10 Supplement

10.1 Technical data

Note for approved instruments

The technical data in the respective safety instructions are valid for approved instruments (e.g. with Ex approval). In some cases, these data can differ from the data listed herein.

All approval documents can be downloaded from our homepage.

General data

Series	Module unit for mounting on carrier rails 35 x 7.5 acc. to EN 50022/60715
Weight	125 g (4.02 oz)
Housing material	Polycarbonate PC-FR
Connection terminals	
– Type of terminal	Screw terminal
– Wire cross-section	0.25 mm ² (AWG 23) ... 2.5 mm ² (AWG 12)

Voltage supply

Operating voltage	
– Nominal voltage AC	24 ... 230 V (-15 %, +10 %) 50/60 Hz
– Nominal voltage DC	24 ... 65 V (-15 %, +10 %)
Max. power consumption	3 W (8 VA)

Sensor input

Quantity	1 x analogue
Input type	Active (sensor power supply by VEGATOR 121)
Measured value transmission	Analogue 8/16 mA
Switching threshold	
– On	12.1 mA
– Off	11.9 mA
– Tolerance	± 500 µA
Current limitation	23 mA (permanently short-circuit proof)
Terminal voltage (idle state)	18.2 V DC, ± 5 %
Internal resistance	200 Ω, ± 1 %
Detection line break	≤ 3.6 mA
Detection shortcircuit	≥ 21 mA

Relay output

Quantity	1 x operating relay, 1 x operating/fail safe relay (optional)
Contact	Floating spdt
Contact material	AgSnO ₂ , hard gold-plated
Switching voltage	min. 10 mV DC, max. 253 V AC/50 V DC
Switching current	min. 10 µA DC, max. 3 A AC, 1 A DC

Breaking capacity ¹⁾	min. 50 mW, max. 500 VA, max. 54 W DC
Phase angle $\cos \phi$ with AC	≥ 0.7
Switch-on/Switch-off delay	
– Basic delay	150 ms, $\pm 20 \%$
– Adjustable delay	2/6/8 s, $\pm 20 \%$

Indicators

LED displays

– Status, operating voltage	1 x LED green
– Status, fault signal	1 x LED red
– Status, operating relay	1 x LED yellow

Adjustment

7 x DIL switch	Setting mode, switching delay, function control, configuration second optional relay
Test key	for function test

Ambient conditions

Ambient temperature at the installation site of the instrument	-20 ... +60 °C (-4 ... +140 °F)
Storage and transport temperature	-40 ... +70 °C (-40 ... +158 °F)
Relative humidity	< 96 %

Mechanical environmental conditions

Vibrations (oscillations)	Class 4M4 acc. to IEC 60721-3-4 (1 g, 4 ... 200 Hz)
Impacts (mechanical shock)	Class 6M4 acc. to IEC 60721-3-6 (10 g/11 ms, 30 g/6 ms, 50 g/2.3 ms)

Electrical protective measures

Protection rating	IP 20
Overvoltage category (IEC 61010-1)	
– up to 2000 m (6562 ft) above sea level	II
– up to 5000 m (16404 ft) above sea level	II - Only with connected overvoltage protection
– up to 5000 m (16404 ft) above sea level	I
Protection class	II
Pollution degree	2

Measures for electrical separation

Reliable separation according to VDE 0106 part 1 between all circuits	
– Reference voltage	253 V

¹⁾ If inductive loads or stronger currents are switched through, the gold plating on the relay contact surface will be permanently damaged. The contact is then no longer suitable for switching low-level signal circuits.

– Insulation resistance

5.1 kV

Approvals

Instruments with approvals can have different technical specifications depending on the version.

For that reason the associated approval documents of these instruments have to be carefully noted. They are part of the delivery or can be downloaded by entering the serial number of your instrument into the search field under www.vega.com as well as in the general download area.

10.2 Dimensions

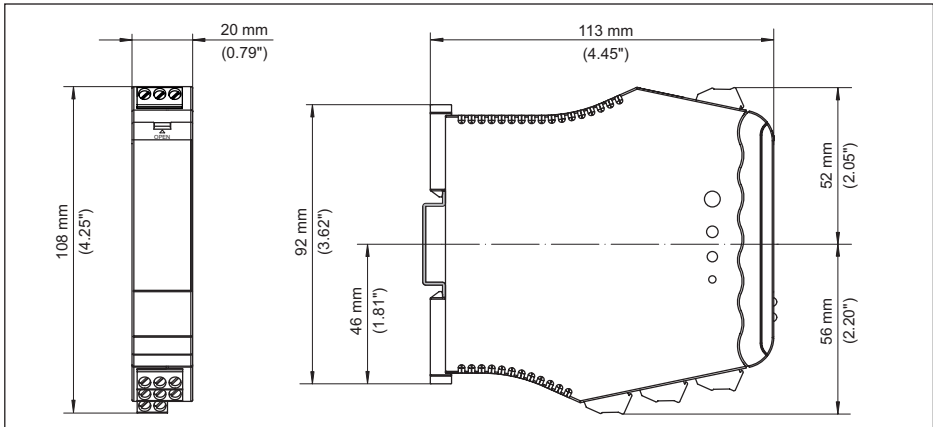

Fig. 6: Dimensions VEGATOR 121

10.3 Industrial property rights

VEGA product lines are global protected by industrial property rights. Further information see www.vega.com.

VEGA Produktfamilien sind weltweit geschützt durch gewerbliche Schutzrechte.

Nähere Informationen unter www.vega.com.

Les lignes de produits VEGA sont globalement protégées par des droits de propriété intellectuelle. Pour plus d'informations, on pourra se référer au site www.vega.com.

VEGA lineas de productos están protegidas por los derechos en el campo de la propiedad industrial. Para mayor información revise la pagina web www.vega.com.

Линии продукции фирмы ВЕГА защищаются по всему миру правами на интеллектуальную собственность. Дальнейшую информацию смотрите на сайте www.vega.com.

VEGA系列产品在全球享有知识产权保护。

进一步信息请参见网站 < www.vega.com。

10.4 Trademark

All the brands as well as trade and company names used are property of their lawful proprietor/originator.

INDEX**C**

Cable screen 10
Carrier rail 9
Causes of malfunction 19
Connection 11
Connection cable 10
Connection terminals 11
Control lamps 13

D

DIL switch 14
Documentation 7
Dry run protection 14

E

Ex version 9

F

Fail safe relay WRA 15
Fault
– Fault signal 19
Fault rectification 19

G

Grounding 10

L

LEDs 13

M

Mode 14

O

Overflow protection 14

P

Potential equalisation 10
Protection rating 9

Q

QR code 7

R

Repair 20

S

Serial number 7
Service hotline 19
SIL 23
Switch-off delay 15

Switch-on delay 15

Switch-on pulse checking 14

T

Test key 15
Type label 7

V

Voltage supply 10







Printing date:

VEGA

All statements concerning scope of delivery, application, practical use and operating conditions of the sensors and processing systems correspond to the information available at the time of printing.

Subject to change without prior notice

© VEGA Grieshaber KG, Schiltach/Germany 2021



57662-EN-210714

VEGA Grieshaber KG
Am Hohenstein 113
77761 Schiltach
Germany

Phone +49 7836 50-0
E-mail: info.de@vega.com
www.vega.com