

**flow switch for water-based fluids
with simultaneous temperature monitoring**



flow-captor 4220.1xF/.1xTM xx °C

The flow-captor type 4220.1xF/.1xT M xx °C is ideally suited for use in automation processes and other industrial applications where both the flow and the temperature of the medium need to be monitored. The sensor operates according to the calorimetric measuring principle and without mechanically moved parts. The sensor detects the flow velocity and the medium temperature and converts both into electrical signals.

- robust stainless steel construction (M)
- precise switching sensor
- separate adjustment of flow range and flow switching point
- factory setting of the temperature switch-point according to customer's specification
- analog display of present flow speed and display of adjusted flow set-point via LED chain
- LED display of operating status
- **ISO 9001:2015**



Control and Display Panel

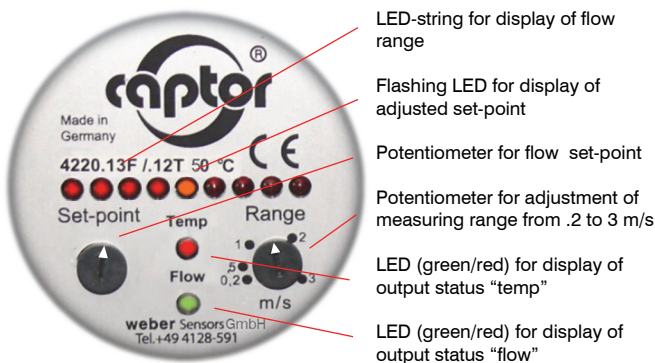

- LED-string for display of flow range
- Flashing LED for display of adjusted set-point
- Potentiometer for flow set-point
- Potentiometer for adjustment of measuring range from .2 to 3 m/s
- LED (green/red) for display of output status "temp"
- LED (green/red) for display of output status "flow"

Example of operation

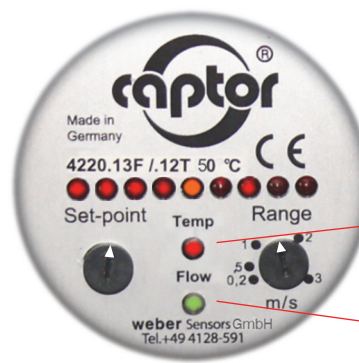

- Measuring range adjusted to 3 m/s = 100 % (9. LED)
- Set-point adjusted to 50 % of end value (5. LED)
- Flow speed equates 75 % (7. LED)
- Temp LED is red: Flow rate is above the adjusted set-point.
- Flow LED is **ON**: Flow rate is above the adjusted set-point.

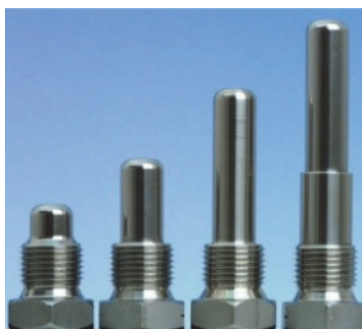

G 1/2" BSP thread in various sensor head lengths

1/2" -14 NPT thread alternatively

Sensor heads

The sensor head is constructed of only one piece of electro-polished stainless steel and without any sensor element intruding into the medium. Easy installation by means of T-piece or welded fitting. For aggressive media special sensor head materials as Titanium or Hastelloy can be offered. The housing is made of stainless steel 303. The electronics inside is completely epoxy resin encapsulated



Sensors GmbH Strohdreich 32
Sensors Ltd. 66 Eastbourne Road, Southport
Sensors LLC. 4462 Bretton Court, Building 1, Suite 7

DE-25377 Kollmar
 Merseyside PR8 4DU, UK
 Acworth, Georgia 30101, USA

Tel.: +49 (0)4128 - 591 · Fax: - 593
 Tel.: +44 (1704) - 551684 · Fax: - 551297
 Tel.: +1 (770) 592 - 6630 · Fax: - 592 6640

www.captor.de
 info@captor.de
 sales@captor.co.uk
 sales@captor.com

**flow switch for water-based fluids
with simultaneous temperature monitoring**



flow-captor 4220.1xF/.1xTM xx °C

Technical data	
Type	4220.1xF/.1xTM xx °C
Medium	water-based
General sensor data	
Medium temperature	-20 °C to +80 °C / -4 °F to +176 °F
Ambient temperature	-20 °C to +70 °C / -4 °F to +158 °F
Pressure	max. 100 bar (1450 PSI)
Sensor data flow	
Measuring range	0 - 20 cm/s to 0 - 300 cm/s, continuously adjustable
Set-point range	approx. 15 % - 90 % of range setting
Response time	2 sec. - 10 sec. depending on range setting
Linearity deviation	< 5 %
Repeatability tolerance	< 2 %
Hysteresis	ca. 10 %
Temperature drift	< 0.3 % K
Sensor data temperature	
Set-point	50 °C, 70 °C, 80 °C / 122 °F, 158 °F, 176 °F (other temperatures on request) temp. set-point should be mentioned on the order
Set-point accuracy	±3 °C / 26.6 °F - 37.4 °F
Response time	approx. 5 sec.
Hysteresis	5 °C / 41 °F
Mechanical data	
Protection class	IP 67
Material of housing	stainless steel AISI 303
Material of sensor probe	stainless steel AISI 303
Electrical connection	4-pin M12 plug (2 m oilflex cable type 4941 must be ordered separately)
Electrical data	
Operating voltage	18 to 30 VDC, incl. residual ripple
Current consumption	max. 150 mA (pulsed)
Power consumption	approx. 1 W
Switching current	≤ 400 mA
Circuit protection	reverse polarity, short circuit and overload
Voltage drop	< 2.5 V at max. load
Initial operation	approx. 10 sec. after connection of power
Output	flow and temperature PNP n.o. and n.c.

types / function table 4220.1xF/.1xTM xx° C				
Flow	pnp output .12F	Flow LED	pnp output .13F	Flow LED
flow > switch point	○	red	●	green
flow < switch point	●	green	○	red
Temperatur	pnp output .12T	Temp. LED	pnp output .13T	Temp. LED
Temperature > switch point	○	red	●	green
Temperature < switch point	●	green	○	red

□ = Standard Series (other combinations on request)
Switching state semiconductor output : ● energized
○ dead

weber

Sensors GmbH Strohdeich 32
Sensors Ltd. 66 Eastbourne Road, Southport
Sensors LLC. 4462 Bretton Court, Building 1, Suite 7

DE-25377 Kollmar
Merseyside PR8 4DU, UK
Acworth, Georgia 30101, USA

Tel.: +49 (0)4128 - 591 · Fax: - 593
Tel.: +44 (1704) - 551684 · Fax: - 551297
Tel.: +1 (770) 592 - 6630 · Fax: - 592 6640

www.captor.de
info@captor.de
sales@captor.co.uk
sales@captor.com

**flow switch for water-based fluids
with simultaneous temperature monitoring**



flow-captor 4220.1xF/.1xTM xx °C

Connection diagram:

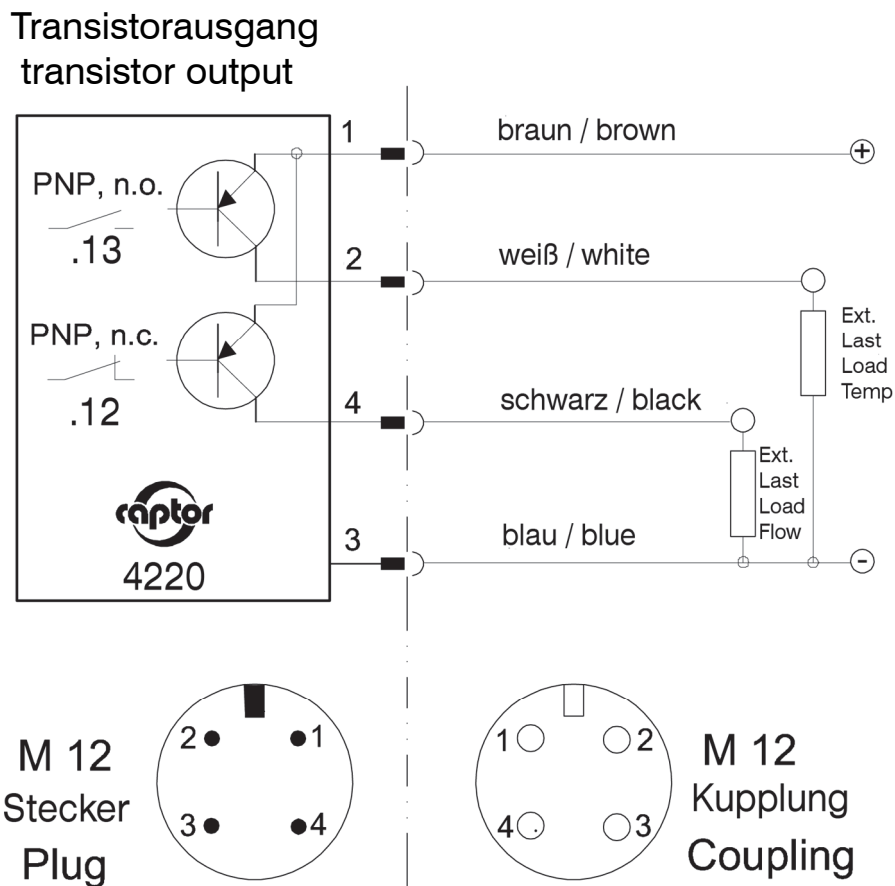

Blick von vorn auf die Stifte und Buchsen
Front view onto the pins and sockets

weber

Sensors GmbH Strohdreich 32

Sensors Ltd. 66 Eastbourne Road, Southport

Sensors LLC. 4462 Bretton Court, Building 1, Suite 7

DE-25377 Kollmar

Merseyside PR8 4DU, UK

Acworth, Georgia 30101, USA

Tel.: +49 (0)4128 - 591 · Fax: - 593

Tel.: +44 (1704) - 551684 · Fax: - 551297

Tel.: +1 (770) 592 - 6630 · Fax: - 592 6640

www.captor.de

info@captor.de

sales@captor.co.uk

sales@captor.com

Technical data subject to alteration! Rev. AG 02.03.22