

# SIEMENS

## SITRANS F

### Ultrasonic Flowmeters SITRANS FS130 & FS230

#### Compact Operating Instructions

<u>Introduction</u>	<b>1</b>
<u>Safety notes</u>	<b>2</b>
<u>Installing/mounting</u>	<b>3</b>
<u>Connecting</u>	<b>4</b>
<u>Commissioning</u>	<b>5</b>
<u>Service and maintenance</u>	<b>6</b>
<u>Technical specifications</u>	<b>7</b>
<u>Dimension drawings</u>	<b>8</b>
<u>Product documentation and support</u>	<b>A</b>

7ME372 (Profibus/HART/Modbus)



**06/2024**

A5E38755607-AG

## Legal information

### Warning notice system

This manual contains notices you have to observe in order to ensure your personal safety, as well as to prevent damage to property. The notices referring to your personal safety are highlighted in the manual by a safety alert symbol, notices referring only to property damage have no safety alert symbol. These notices shown below are graded according to the degree of danger.

 <b>DANGER</b>
indicates that death or severe personal injury <b>will</b> result if proper precautions are not taken.
 <b>WARNING</b>
indicates that death or severe personal injury <b>may</b> result if proper precautions are not taken.
 <b>CAUTION</b>
indicates that minor personal injury can result if proper precautions are not taken.
<b>NOTICE</b>
indicates that property damage can result if proper precautions are not taken.

If more than one degree of danger is present, the warning notice representing the highest degree of danger will be used. A notice warning of injury to persons with a safety alert symbol may also include a warning relating to property damage.

### Qualified Personnel

The product/system described in this documentation may be operated only by **personnel qualified** for the specific task in accordance with the relevant documentation, in particular its warning notices and safety instructions. Qualified personnel are those who, based on their training and experience, are capable of identifying risks and avoiding potential hazards when working with these products/systems.

### Proper use of Siemens products

Note the following:

 <b>WARNING</b>
Siemens products may only be used for the applications described in the catalog and in the relevant technical documentation. If products and components from other manufacturers are used, these must be recommended or approved by Siemens. Proper transport, storage, installation, assembly, commissioning, operation and maintenance are required to ensure that the products operate safely and without any problems. The permissible ambient conditions must be complied with. The information in the relevant documentation must be observed.

### Trademarks

All names identified by ® are registered trademarks of Siemens Aktiengesellschaft. The remaining trademarks in this publication may be trademarks whose use by third parties for their own purposes could violate the rights of the owner.

### Disclaimer of Liability

We have reviewed the contents of this publication to ensure consistency with the hardware and software described. Since variance cannot be precluded entirely, we cannot guarantee full consistency. However, the information in this publication is reviewed regularly and any necessary corrections are included in subsequent editions.

# Table of contents

<b>1</b>	<b>Introduction</b>	<b>7</b>
1.1	Purpose of this documentation	7
1.2	Product compatibility	7
1.3	Designated use	8
1.4	Checking the consignment	9
1.5	Security information	9
1.6	Transportation and storage	10
1.7	Notes on warranty	10
<b>2</b>	<b>Safety notes</b>	<b>11</b>
2.1	Preconditions for use	11
2.1.1	Warning symbols on the device	11
2.1.2	Laws and directives	11
2.1.3	Conformity with European directives	12
2.1.4	CE declaration	12
2.2	Requirements for special applications	12
2.3	Use in hazardous areas	13
2.3.1	Sensor installation in hazardous areas	14
<b>3</b>	<b>Installing/mounting</b>	<b>17</b>
3.1	Basic safety notes	17
3.1.1	Wall mount enclosure specific conditions of use	17
3.1.2	Industrial enclosure specific conditions of use	17
3.1.3	External DSL specific conditions of use	18
3.1.4	Installation location requirements	19
3.2	FS130 system overview (internal DSL)	20
3.3	FS130 system overview (external DSL)	21
3.4	FS230 system overview (internal DSL)	23
3.5	FS230 system overview (external DSL)	24
3.6	Installation Instructions	25
3.6.1	Industrial enclosure	25
3.6.1.1	Mounting on wall	25
3.6.1.2	Mounting on pipe	25
3.6.1.3	Mounting the transmitter	26
3.6.1.4	Turning the transmitter	26
3.6.1.5	Turning the local display	27
3.6.2	Wall mount enclosure	28
3.6.3	Mounting the external DSL	30
3.7	Installing sensors in Reflect mount	32

3.8	Incorrect mounting .....	33
3.9	Disassembly .....	34
<b>4</b>	<b>Connecting .....</b>	<b>35</b>
4.1	Basic safety notes.....	35
4.1.1	Spark ignition hazard .....	36
4.2	Connecting the sensor cables (internal DSL only).....	39
4.3	Connecting the sensor cables to the sensor .....	40
4.4	HI Precision mount FST030 .....	42
4.5	Connecting the external DSL .....	46
4.5.1	Preparing for the external DSL connections.....	46
4.5.2	Connecting the sensor cables .....	47
4.5.3	Channel 5 and 6 input configuration .....	48
4.5.4	Connecting optional devices .....	49
4.5.5	Connecting the SSL cable .....	52
4.5.6	Finishing the DSL connection .....	54
4.6	Connecting industrial enclosure .....	55
4.6.1	Preparing industrial enclosure connections.....	55
4.6.1.1	Terminal layout (industrial enclosure).....	56
4.6.1.2	Wiring tool.....	57
4.6.2	Connecting the SSL cable (industrial enclosure).....	58
4.6.3	Connecting Modbus.....	59
4.6.4	Connecting HART .....	60
4.6.5	Connecting channels 2 to 4.....	63
4.6.6	Connecting the power supply.....	63
4.6.7	Finishing the transmitter connection (Industrial enclosure).....	65
4.7	Connecting wall mount enclosure .....	66
4.7.1	Preparing wall mount enclosure connections.....	66
4.7.1.1	Terminal layout (wall mount) .....	67
4.7.2	Connecting the sensor cables (internal DSL only).....	68
4.7.3	Connecting the SSL cable (wall mount enclosure).....	69
4.7.4	Connecting Modbus (wall mount) .....	73
4.7.5	Connecting HART .....	74
4.7.6	Connecting channels 2 to 4.....	75
4.7.6.1	Input/output configuration .....	77
4.7.7	Connecting channels 5 and 6 (internal DSL only) .....	79
4.7.8	Connecting the power supply (wall mount) .....	80
4.7.9	Finishing the transmitter connection (wall mount) .....	82
<b>5</b>	<b>Commissioning .....</b>	<b>85</b>
5.1	Basic Safety Notes .....	85
5.2	Local display .....	87
5.3	Access control.....	88
5.4	Device startup .....	89
<b>6</b>	<b>Service and maintenance .....</b>	<b>91</b>
6.1	Basic safety notes.....	91



---

6.2	Cleaning .....	92
6.3	Maintenance and repair work.....	92
6.3.1	On-board battery replacement .....	94
6.4	Return procedure .....	94
6.5	Disposal.....	95
<b>7</b>	<b>Technical specifications .....</b>	<b>97</b>
7.1	Power .....	97
7.2	HART interface.....	97
7.3	Modbus interface.....	98
7.4	Inputs .....	98
7.5	Outputs .....	99
7.6	Energy limitation parameters FST030 .....	101
7.7	Energy limitation parameters for external DSL .....	104
7.8	Construction.....	105
7.9	Operating conditions .....	107
7.10	Cables and cable entries.....	108
7.11	Certificates and approvals.....	110
7.12	Approvals .....	110
7.13	SensorFlash .....	112
<b>8</b>	<b>Dimension drawings .....</b>	<b>113</b>
8.1	Transmitter .....	113
8.1.1	Industrial enclosure dimensions .....	113
8.2	Mounting bracket dimensions .....	114
8.3	External DSL dimensions .....	114
<b>A</b>	<b>Product documentation and support .....</b>	<b>115</b>
A.1	Product documentation .....	115
A.2	Technical support.....	116
	<b>Index.....</b>	<b>117</b>



# Introduction

## 1.1 Purpose of this documentation

These instructions are a brief summary of important features, functions and safety information, and contain all information required for safe use of the device. Read the instructions carefully prior to installation and commissioning. In order to use the device correctly, first review its principle of operation.

The instructions are aimed at persons who install and commission the device.

To realize optimum performance from the device, read the complete operating instructions.

## 1.2 Product compatibility

Manual edition	Remarks	Device revision	Compatible version of device integration package	
06/2024	PROFIBUS support	HART/Modbus/PROFIBUS FW: 1.07.00 for gas and liquid HW: 002 and 003 Device revision 7 or later	SIMATIC PDM V9.2 SP 2	EDD: 1.07.01
			AMS Device Manager 14.0, 14.1	
			SITRANS DTM 4.3	
			Field communicator V3.8	
12/2023	FSS100 support	HART/Modbus FW: 1.07.00 for gas and liquid HW: 002 and 003 Device revision 7 or later	SIMATIC PDM V9.1 Update 6 or later	EDD: 1.07.00
			AMS Device Manager 14.0, 14.1	
			SITRANS DTM 4.2	
			Field communicator V3.8	
02/2023	Updated manuals	HART/Modbus FW: 1.05.00 for gas and liquid HW: 002 and 003 Device revision 5 or later	SIMATIC PDM V9.1 Update 6 or later	EDD: 1.06.00
			AMS Device Manager 14.0, 14.1	
			SITRANS DTM 4.2	
			Field communicator V3.8	
09/2022	Defects solved	HART/Modbus FW: 1.06.01 for gas and liquid HW: 002 and 003 Device revision 5 or later	SIMATIC PDM V9.1 Update 6 or later	EDD: 1.06.00
			AMS Device Manager 14.0, 14.1	
			SITRANS DTM 4.2	
			Field communicator V3.8	

## 1.3 Designated use

Manual edition	Remarks	Device revision	Compatible version of device integration package	
09/2021	New functionality	HART/Modbus FW: 1.05.00 for gas and liquid HW: 002 and 003 Device revision 5 or later	SIMATIC PDM V9.1 Update 6 or later	EDD: 1.05.00
			AMS Device Manager 14.0, 14.1	
			SITRANS DTM 4.2	
			Field communicator V3.8	
06/2021	Industrial enclosure support	HART/Modbus FW: 1.04.00 for gas FW: 1.03.00 for liquid (clamp-on and inline) HW: 002 and 003 Device revision 5 or later	SIMATIC PDM V8.2 or later	EDD: 1.04.00
			AMS Device Manager 12.0 or later	
			SITRANS DTM V4.1	
			Field communicator V3.8	
12/2019	Gas installations support	HART/Modbus FW: 1.04.00 for gas FW: 1.03.00 for liquid (clamp-on and inline) HW: 002 and 003 Device revision 5 or later	SIMATIC PDM V8.2 or later	EDD: 1.04.00
			AMS Device Manager 12.0 or later	
			SITRANS DTM V4.1	
			Field communicator V3.8	
08/2018	Defect solved	HART/Modbus FW: 1.00.01 HW: 002 Device revision 4 or later	SIMATIC PDM V8.2 or later	EDD: 1.02.00
			AMS Device Manager 12.0 or later	
			SITRANS DTM V4.1	
			Field communicator V3.8	
08/2017	Updated manuals	HART/Modbus FW: 1.00.00 HW: 002 Device revision 3 or later	SIMATIC PDM V8.2 or later	EDD: 1.00.00 or 1.01.00
			AMS Device Manager 12.0 or later	
			SITRANS DTM V4.1	
			Field communicator V3.8	
02/2017	First edition Liquid installations support	HART/Modbus FW: 1.00.00 HW: 002 Device revision 3 or later	SIMATIC PDM V8.2 or later	EDD: 1.00.00 or 1.01.00
			AMS Device Manager 12.0 or later	
			SITRANS DTM V4.1	
			Field communicator V3.8	

## 1.3 Designated use

Use the device to measure process medium in accordance with the information in the operating instructions.

**NOTICE****Use in a domestic environment**

This Class A Group 1 equipment is intended for use in industrial areas.

In a domestic environment this device may cause radio interference.

## 1.4 Checking the consignment

1. Check the packaging and the delivered items for visible damages.
2. Report any claims for damages immediately to the shipping company.
3. Retain damaged parts for clarification.
4. Check the scope of delivery by comparing your order to the shipping documents for correctness and completeness.

** WARNING****Using a damaged or incomplete device**

Risk of explosion in hazardous areas.

- Do not use damaged or incomplete devices.

## 1.5 Security information

Siemens provides products and solutions with industrial security functions that support the secure operation of plants, systems, machines and networks.

In order to protect plants, systems, machines and networks against cyber threats, it is necessary to implement – and continuously maintain – a holistic, state-of-the-art industrial security concept. Siemens' products and solutions constitute one element of such a concept.

Customers are responsible for preventing unauthorized access to their plants, systems, machines and networks. Such systems, machines and components should only be connected to an enterprise network or the internet if and to the extent such a connection is necessary and only when appropriate security measures (e.g. firewalls and/or network segmentation) are in place.

For additional information on industrial security measures that may be implemented, please visit

<https://www.siemens.com/industrialsecurity>.

Siemens' products and solutions undergo continuous development to make them more secure. Siemens strongly recommends that product updates are applied as soon as they are available and that the latest product versions are used. Use of product versions that are no longer supported, and failure to apply the latest updates may increase customer's exposure to cyber threats.

To stay informed about product updates, subscribe to the Siemens Industrial Security RSS Feed under <https://www.siemens.com/cert>.

## 1.6 Transportation and storage

To guarantee sufficient protection during transport and storage, observe the following:

- Keep the original packaging for subsequent transportation.
- Devices/replacement parts should be returned in their original packaging.
- If the original packaging is no longer available, ensure that all shipments are properly packaged to provide sufficient protection during transport. Siemens cannot assume liability for any costs associated with transportation damages.

<b>NOTICE</b>
<b>Insufficient protection during storage</b> The packaging only provides limited protection against moisture and infiltration. <ul style="list-style-type: none"><li>• Provide additional packaging as necessary.</li></ul>

Special conditions for storage and transportation of the device are listed in Technical specifications (Page 97).

## 1.7 Notes on warranty

The contents of this manual shall not become part of or modify any prior or existing agreement, commitment or legal relationship. The sales contract contains all obligations on the part of Siemens as well as the complete and solely applicable warranty conditions. Any statements regarding device versions described in the manual do not create new warranties or modify the existing warranty.

The content reflects the technical status at the time of publishing. Siemens reserves the right to make technical changes in the course of further development.

## Safety notes

### 2.1 Preconditions for use

This device left the factory in good working condition. In order to maintain this status and to ensure safe operation of the device, observe these instructions and all the specifications relevant to safety.

Observe the information and symbols on the device. Do not remove any information or symbols from the device. Always keep the information and symbols in a completely legible state.

#### 2.1.1 Warning symbols on the device

Symbol	Explanation
	Consult operating instructions

 <b>WARNING</b>
<p><b>Improper device modifications</b></p> <p>Risk to personnel, system, and environment can result from modifications to the device, particularly in hazardous areas.</p> <ul style="list-style-type: none"> <li>• Only carry out modifications that are described in the instructions for the device. Failure to observe this requirement cancels the manufacturer's warranty and the product approvals. Do not operate the device after unauthorized modifications.</li> </ul>

#### 2.1.2 Laws and directives

Observe the safety rules, provisions and laws applicable in your country during connection, assembly and operation. These include, for example:

- National Electrical Code (NEC - NFPA 70) (USA)
- Canadian Electrical Code (CEC Part I) (Canada)

Further provisions for hazardous area applications are for example:

- IEC 60079-14 (international)
- EN 60079-14 (EU and UK)

### 2.1.3 Conformity with European directives

The CE marking on the device symbolizes the conformity with the following European directives:

Electromagnetic compatibility EMC 2014/30/EU	Directive of the European Parliament and of the Council on the harmonisation of the laws of the Member States relating to electromagnetic compatibility
Low voltage directive LVD 2014/35/EU	Directive of the European Parliament and of the Council on the harmonisation of the laws of the Member States relating to the making available on the market of electrical equipment designed for use within certain voltage limits
Atmosphère explosive ATEX 2014/34/EU	Directive of the European Parliament and the Council on the harmonisation of the laws of the Member States relating to equipment and protective systems intended for use in potentially explosive atmospheres
RoHS directive 2011/65/EU	Directive of the European Parliament and the Council on the restriction of the use of certain hazardous substances in electrical and electronic equipment.

The applicable directives can be found in the EU declaration of conformity of the specific device.

### 2.1.4 CE declaration

---

**Note**

**CE declaration**

The CE declaration certificate is available on the SensorFlash SD card delivered with the device.

---

## 2.2 Requirements for special applications

Due to the large number of possible applications, each detail of the described device versions for each possible scenario during commissioning, operation, maintenance or operation in systems cannot be considered in the instructions. If you need additional information not covered by these instructions, contact your local Siemens office or company representative.

---

**Note**

**Operation under special ambient conditions**

We highly recommend that you contact your Siemens representative or our application department before you operate the device under special ambient conditions as can be encountered in nuclear power plants or when the device is used for research and development purposes.

---





## 2.3 Use in hazardous areas

### Qualified personnel for hazardous area applications

Persons who install, connect, commission, operate, and service the device in a hazardous area must have the following specific qualifications:

- They are authorized, trained or instructed in operating and maintaining devices and systems according to the safety regulations for electrical circuits, high pressures, aggressive, and hazardous media.
- They are authorized, trained, or instructed in carrying out work on electrical circuits in hazardous areas.
- They are trained or instructed in maintenance and use of appropriate safety equipment according to the pertinent safety regulations.

 <b>WARNING</b>
<p><b>Use in hazardous area</b></p> <p>Risk of explosion.</p> <ul style="list-style-type: none"> <li>• Only use equipment that is approved for use in the intended hazardous area and labeled accordingly.</li> <li>• Do not use devices that have been operated outside the conditions specified for hazardous areas. If you have used the device outside the conditions for hazardous areas, make all Ex markings unrecognizable on the nameplate.</li> </ul>

 <b>WARNING</b>
<p><b>Loss of safety of device with type of protection "Intrinsic safety Ex i"</b></p> <p>If the device or its components have already been operated in non-intrinsically safe circuits or the electrical specifications have not been observed, the safety of the device is no longer ensured for use in hazardous areas. There is a risk of explosion.</p> <ul style="list-style-type: none"> <li>• Connect the device with type of protection "Intrinsic safety" solely to an intrinsically safe circuit.</li> <li>• Observe the specifications for the electrical data on the certificate and/or in Technical specifications (Page 97).</li> </ul>

 <b>WARNING</b>
<p><b>Dust layers above 5 mm</b></p> <p>Risk of explosion in hazardous areas.</p> <p>Device may overheat due to dust build up.</p> <ul style="list-style-type: none"> <li>• Remove dust layers in excess of 5 mm.</li> </ul>

2.3 Use in hazardous areas

 <b>WARNING</b>
<b>Substitution of components</b>
Substitution of components may impair Intrinsic Safety.

 <b>WARNING</b>
<b>Laying of cables</b>
Risk of explosion in hazardous areas. May cause death or serious injury.
Cable for use in hazardous areas must satisfy the requirements for having a proof voltage of at least 500 V AC applied between the conductor/ground, conductor/shield and shield/ground.
Connect the devices that are operated in hazardous areas as per the stipulations applicable in the country of operation.

 <b>WARNING</b>
<b>Field wiring installation</b>
Risk of explosion in hazardous areas. May cause death or serious injury.
Ensure that the national requirements of the country in which the devices are installed are met.

2.3.1 Sensor installation in hazardous areas

Hazardous area approvals

The device is approved for use in hazardous area according to the lists below. Specific conditions of safe use specified by each approval authority are included in the relevant certificate.

"Intrinsic safety" type of protection	
Canada, USA <ul style="list-style-type: none"> <li>• FM16CA0142X</li> <li>• FM16US0280X</li> <li>• CSA 80083297X</li> </ul>	Class I, Division 1, Groups A, B, C, D Class II, Division 1, Groups E, F, G Class III Class I, Zone 0, AEx/ Ex ia IIC T6 ... T4 Ga Class II, Zone 21 AEx/ Ex ib IIIC T70°C ... T110°C Db
ATEX, UKEx, IECEx <ul style="list-style-type: none"> <li>• IECEx FMG 17.0004X</li> <li>• FM 16ATEX0090X</li> <li>• FM21UKEX0057X</li> </ul>	II 1G Ex ia IIC T6...T4 Ga II 2D Ex ib IIIC T70 – 110 °C Db
EAC Ex	OEx ia IIC T6...T4 Ga X Ex ia IIIC T70°C...T110°C Da
Temperature code	Varies by sensor and ambient temperature (see tables below)
Dust Temperature class	Tdust = Ta max + 10 °K (T70 °C for Ta = 60 °C, T110 °C for Ta = 100 °C)

Table 2-1 FSS200 Size A and B High Precision Sensor; Entity Parameters:  $U_i = 17.44$  V,  $I_i = 461$  mA,  $P_i = 1.00$  W

MLFB Number	Type	Ci (nF)	Li (uH)	Temperature code
7ME3950aLbcd	Liquid	4.4	16	T5 for $T_a \leq 85$ °C T4 for $T_a \leq 100$ °C
7ME3950aGbcd	Gas	1	50	T5 for $T_a \leq 85$ °C T4 for $T_a \leq 100$ °C

Where,

a = Approval: 5 (FM/CSA/ATEX/IECEX)

b = G,H,J,K,L, or T

c = Temperature 0 (normal), 2 (104°C) or 3 (121°C)

d = Corrosion Protection: 0 (Standard) or 1 (Corrosion Resistant)

Table 2-2 FSS200 Size C and D High Precision Sensors; Entity Parameters:  $U_i = 17.44$  V,  $I_i = 461$  mA,  $P_i = 1.00$  W

MLFB Number	Type	Ci (nF)	Li (uH)	Temperature code
7ME3950aLbcd	Liquid	3.4	0	T5 for $T_a \leq 85$ °C T4 for $T_a \leq 100$ °C
7ME3950aGbcd	Gas	56	0	T5 for $T_a \leq 85$ °C T4 for $T_a \leq 100$ °C

Where,

a = Approval: 5 (FM/CSA/ATEX/IECEX)

b = M,N,P,Q,U or R

c = Temperature 0 (normal), 2 (104 °C) or 3 (121 °C)

d = Corrosion Protection: 0 (Standard) or 1 (Corrosion Resistant)

Table 2-3 FSS200 Size A,B,C, D, and E Universal Sensors; Entity Parameters:  $U_i = 17.44$  V;  $I_i = 461$  mA,  $P_i = 1.00$  W

MLFB Number	Type	Ci (nF)	Li (uH)	Temperature code
7ME3950aLbc	Liquid	8.1	28.4	T5 for $T_a \leq 60$ °C T4 for $T_a \leq 100$ °C
7ME3950aGbc	Gas	55	0	T5 for $T_a \leq 60$ °C T4 for $T_a \leq 100$ °C

Where,

a = Approval: 5 (FM/CSA/ATEX/IECEX)

b = Size: B0,B1,C0,C1,C2,D0,D1,D2,E0,E1,E2,F0,F1,F2

c = Corrosion Protection: 0 (Standard) or 1 (Corrosion Resistant)

Table 2-4 FSS200 Doppler Sensors; Entity Parameters:  $U_i = 17.44$  V,  $I_i = 461$  mA,  $P_i = 1.00$  W

MLFB Number	Ci (nF)	Li (uH)	Temperature code
7ME3950aLS0b	123	0	T6 for $T_a \leq 60$ °C T5 for $T_a \leq 100$ °C

Where,

a = Approval: 5 (FM/CSA/ATEX/IECEX)

b = Corrosion Protection: 0 (Standard) or 1 (Corrosion Resistant)

Safety notes

2.3 Use in hazardous areas

Table 2-5 FSS200 Very High Temperature Sensors; Entity Parameters:  $U_i = 17.44\text{ V}$ ,  $I_i = 461\text{ mA}$ ,  $P_i = 1.00\text{ W}$

MLFB Number	Ci (nF)	Li (uH)	Temperature code
7ME3950aLAb	0	0	T5 for $T_a \leq 85\text{ }^\circ\text{C}$ T4 for $T_a \leq 100\text{ }^\circ\text{C}$

Where,

a = Approval: 5 (FM/CSA/ATEX/IECEX)

b = Size: 13,23,33,43,63,73,83

---

**Note**

**Control drawing**

\* See Control drawing A5E37305975A

---

**Installation variations**

---

**Note**

**Requirements for safe installation**

- The sensors can be installed in Zone 0, Div. 1 as Intrinsically Safe.
  - Standard remote installation with FST030 because the connection is certified Intrinsically Safe.
-

## Installing/mounting

### 3.1 Basic safety notes

#### 3.1.1 Wall mount enclosure specific conditions of use

1. WARNING – Risk of electrostatic sparking. Clean only with a damp cloth.
2. 7ME372, 7ME382 and 7ME383 wall mount enclosure transmitter threaded entries require a seal or gasket.
3. Temperature code T6 applies for ambient temperatures up to 45 °C; Temperature code T5 applies for ambient temperatures between 45 °C and 60 °C. The dust temperature class T85°C applies for ambient temperatures to 60 °C.
4. The equipment shall only be used in an area of at least pollution degree 2, as defined by IEC 60664-1.
5. Using the box provided on the nameplate, the user shall permanently mark the type of protection chosen for the specific installation. Once the type of protection has been marked, it shall not be changed.

---

**Note****Pollution degree 2**

Pollution degree 2 can be achieved by controlling the micro environment within the equipment by maintaining IP65.

---

#### 3.1.2 Industrial enclosure specific conditions of use

1. The SITRANS FST030 shall only be electrically powered / connected to an overvoltage category II or better circuit as defined in IEC 60664-1 and required by Annex F of IEC 60079-11.
2. The quoted entity parameters of Co and Lo are applicable for the distributed capacitance and inductance in cables. Where there is circuit capacitance or inductance in the connected equipment (represented by Ci and Li) that both total more than 1% of quoted Co and Lo then the Co and Lo of the connected equipment shall not exceed 50% of the quoted Co and Lo values.
3. The maximum dust layer shall be no greater than 5 mm (T<sub>5</sub> 85°C).
4. The SITRANS FST030 industrial enclosure shall be bonded to the enclosure of the sensor (e.g. SITRANS FSS200) that is powered via the “SSL Interface”, M12 Connector (Pins 1 to 4).
5. The wiring shall be given protection against torsional and tensile stresses (e.g. by the use of conduit).

6. The equipment includes flamepath joints. Consult the manufacturer if repair of the flamepath joints is necessary.
7. Consult the manufacturer for genuine replacement parts.
8. Risk of electrostatic sparking. Clean only with a damp cloth.

### 3.1.3 External DSL specific conditions of use

1. ATEX/IECEX: Potential risk of sparking from aluminium alloy enclosure. In Zone 0 installations, equipment shall be installed in such manner as to prevent the possibility of sparks resulting from friction or impact against the enclosure.
2. US/Canada: Potential risk of sparking from aluminium alloy enclosure. In Division 1 or Zone 0 installations, equipment shall be installed in such manner as to prevent the possibility of sparks resulting from friction or impact against the enclosure.
3. WARNING – Risk of electrostatic sparking. Clean only with a damp cloth.
4. Group IIIC dust rating is only valid for a maximum dust layer of 5 mm.
5. Temperature code T6 and dust temperature class T<sub>5</sub> 64 °C applies for ambient temperatures up to 50 °C; Temperature code T5 and dust temperature class T<sub>5</sub> 74 °C applies for ambient temperatures between 50 °C and 60 °C.



#### CAUTION

##### Hot surfaces resulting from hot process media

Risk of burns resulting from surface temperatures above 65 °C (149 °F).

- Take appropriate protective measures, for example contact protection.
- Make sure that protective measures do not cause the maximum permissible ambient temperature to be exceeded. Refer to the information in Technical specifications (Page 97).



#### WARNING

##### Exceeded maximum permissible operating pressure

Risk of injury or poisoning.

The maximum permissible operating pressure depends on the device version, pressure limit and temperature rating. The device can be damaged if the operating pressure is exceeded. Hot, toxic and corrosive process media could be released.

Ensure that maximum permissible operating pressure of the device is not exceeded. Refer to the information on the nameplate and/or in Technical specifications (Page 97).

### 3.1.4 Installation location requirements

<b>NOTICE</b>
<b>Strong vibrations</b> Damage to device. <ul style="list-style-type: none"><li>• In installations with strong vibrations, mount the device in a low vibration environment.</li></ul>

<b>NOTICE</b>
<b>Aggressive atmospheres</b> Damage to device through penetration of aggressive vapors. <ul style="list-style-type: none"><li>• Ensure that the device is suitable for the application.</li></ul>

<b>NOTICE</b>
<b>Direct sunlight</b> Damage to device. The device can overheat or materials become brittle due to UV exposure. <ul style="list-style-type: none"><li>• Protect the device from direct sunlight.</li><li>• Make sure that the maximum permissible ambient temperature is not exceeded. Refer to the information in Technical specifications (Page 97).</li></ul>

### 3.2 FS130 system overview (internal DSL)

The illustration below shows a typical FST030 transmitter and FSS100 sensor flowmeter configuration.

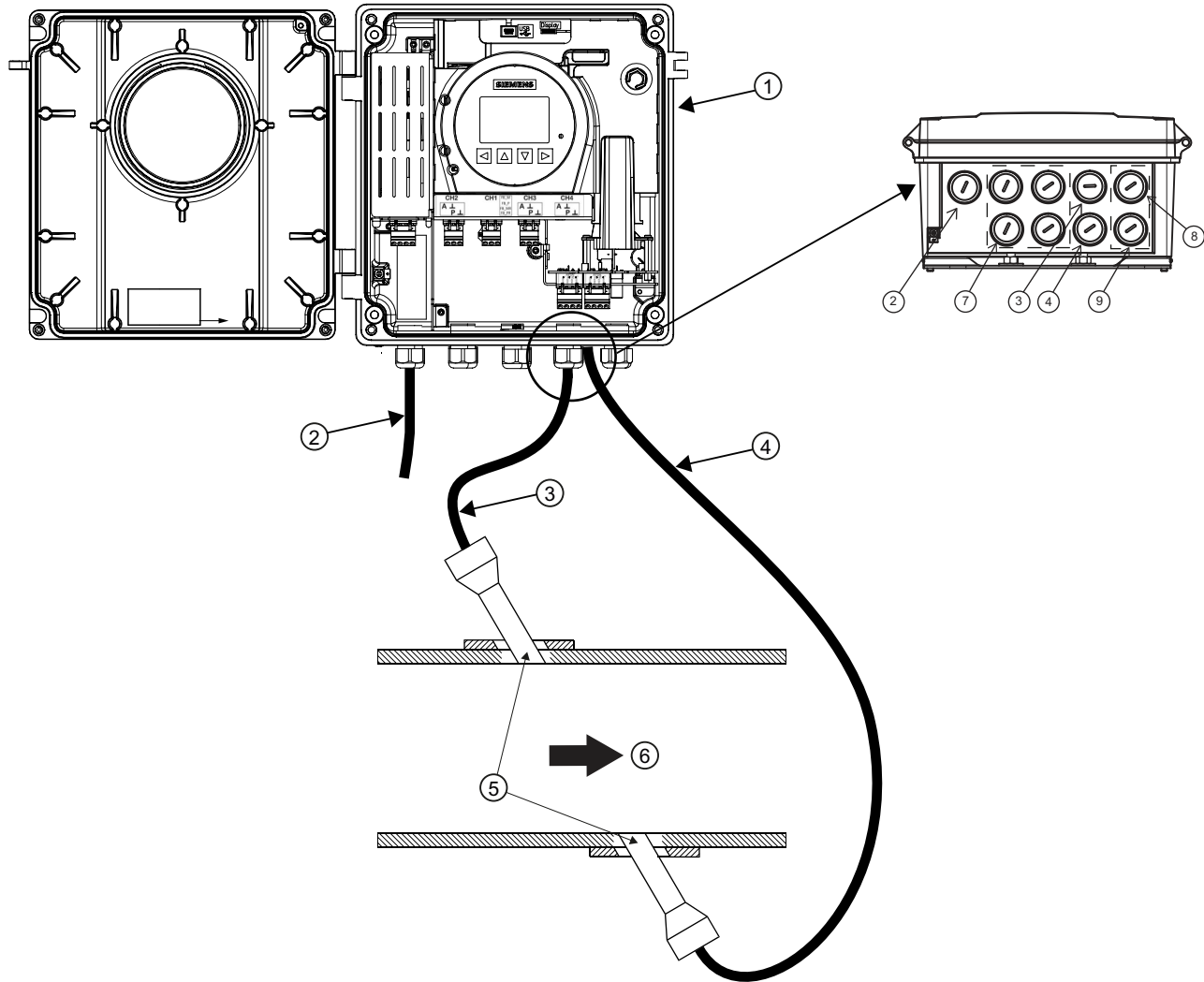

- |   |                                       |
|---|---------------------------------------|
| ① FST030 wall mount enclosure transmitter | ⑥ Flow direction                      |
| ② Power cable                             | ⑦ Ports for I/O, Communications, RTDs |
| ③ Path 1 - Upstream sensor cable (1A)     | ⑧ Path 2 - Upstream (2A)              |
| ④ Path 1 - Downstream sensor cable (1B)   | ⑨ Path 2 - Downstream (2B)            |
| ⑤ Sensors                                 |                                       |

Figure 3-1 Wall mount enclosure transmitter overview with FSS100 - FS130



### 3.3 FS130 system overview (external DSL)

The illustration below shows a typical FST030 transmitter and FSS100 sensor flowmeter configuration with external DSL. You can also connect the transmitter to other flow ultrasonic sensors.

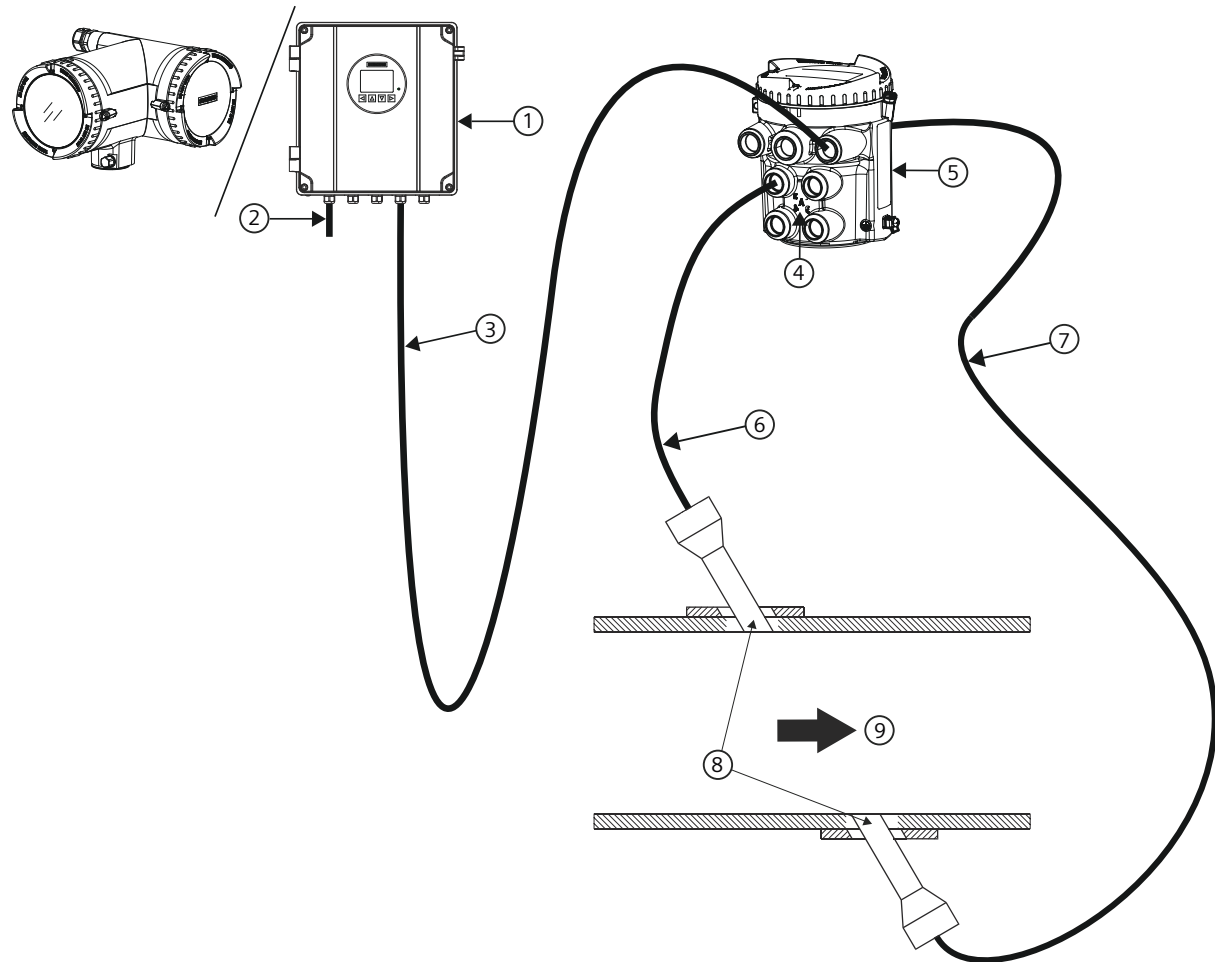

Wall mount transmitter overview with FS DSL11

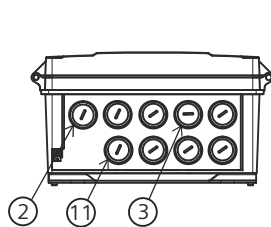

Transmitter bottom view

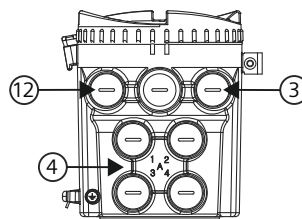

External DSL side view A

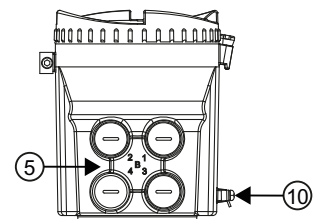

External DSL side view B

3.3 FS130 system overview (external DSL)

- |   |                                  |
|---|----------------------------------|
| ① FST030 wall mount or industrial enclosure transmitter         | ⑦ Path 1-4 downstream (B)        |
| ② Power cable   | ⑧ Sensors                        |
| ③ Cable connection between FST030 and external DSL, up to 150 m | ⑨ Flow direction                 |
| ④ Path 1-4 upstream (A)   | ⑩ Protective earth               |
| ⑤ Path 1-4 downstream (B)                                       | ⑪ Ports for I/O, Communications  |
| ⑥ Path 1-4 upstream (A)   | ⑫ Ports for analog input or RTDs |

### 3.4 FS230 system overview (internal DSL)

#### System overview with internal DSL

The illustration below shows a typical transmitter and clamp-on sensor flowmeter configuration.

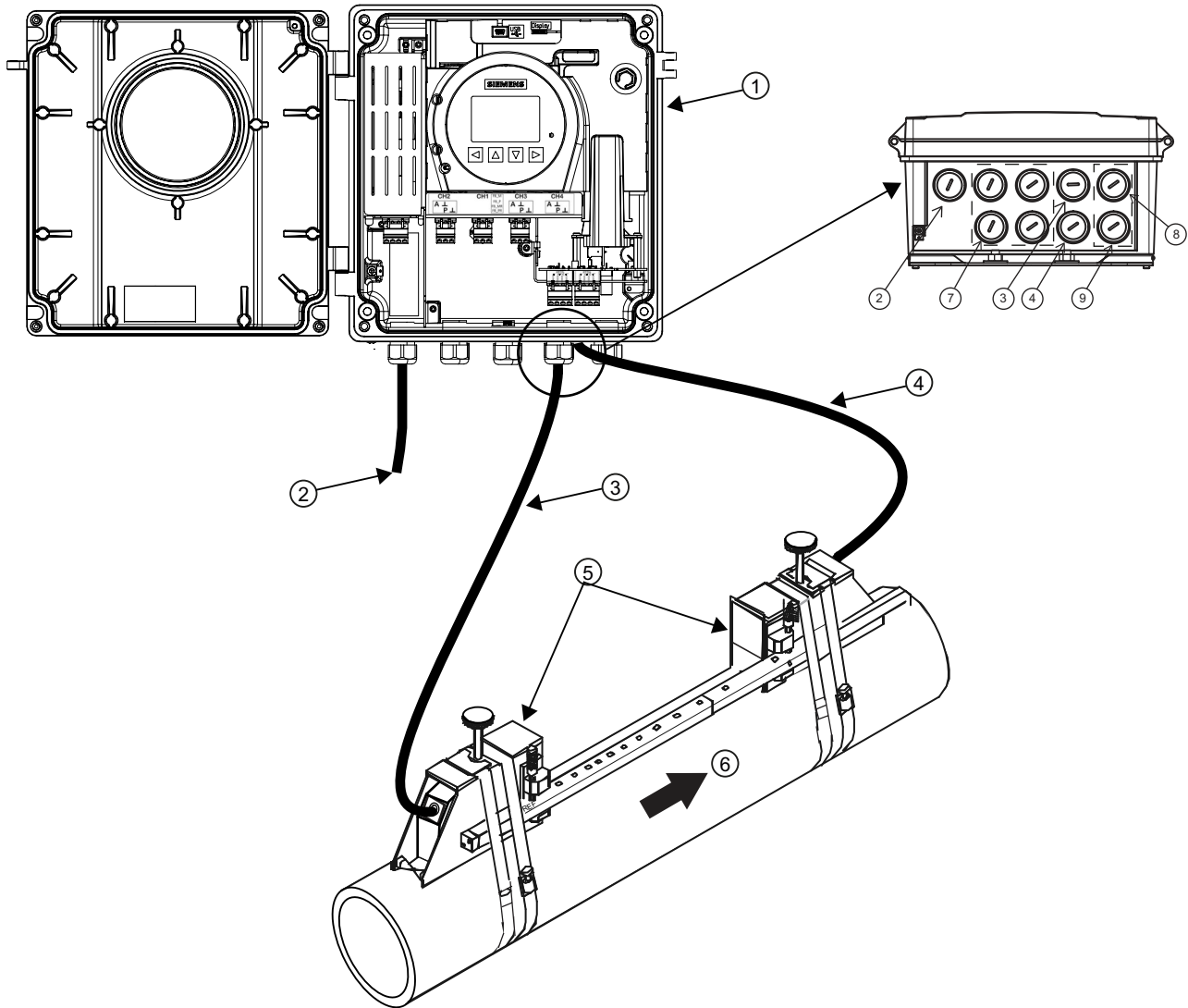

- |   |                                       |
|---|---------------------------------------|
| ① FST030 wall mount enclosure transmitter | ⑤ Sensors                             |
| ② Power cable                             | ⑥ Flow direction                      |
| ③ Path 1 - upstream sensor cable (1A)     | ⑦ Ports for I/O, Communications, RTDs |
| ④ Path 1 - downstream sensor cable (1B)   | ⑧ Path 2 - upstream (2A)              |
|   | ⑨ Path 2 - downstream (2B)            |

Figure 3-2 Wall mount transmitter overview (reflect mount)

### 3.5 FS230 system overview (external DSL)

#### System overview with external DSL

The illustration below shows a typical transmitter and clamp-on sensor flowmeter configuration with external DSL.

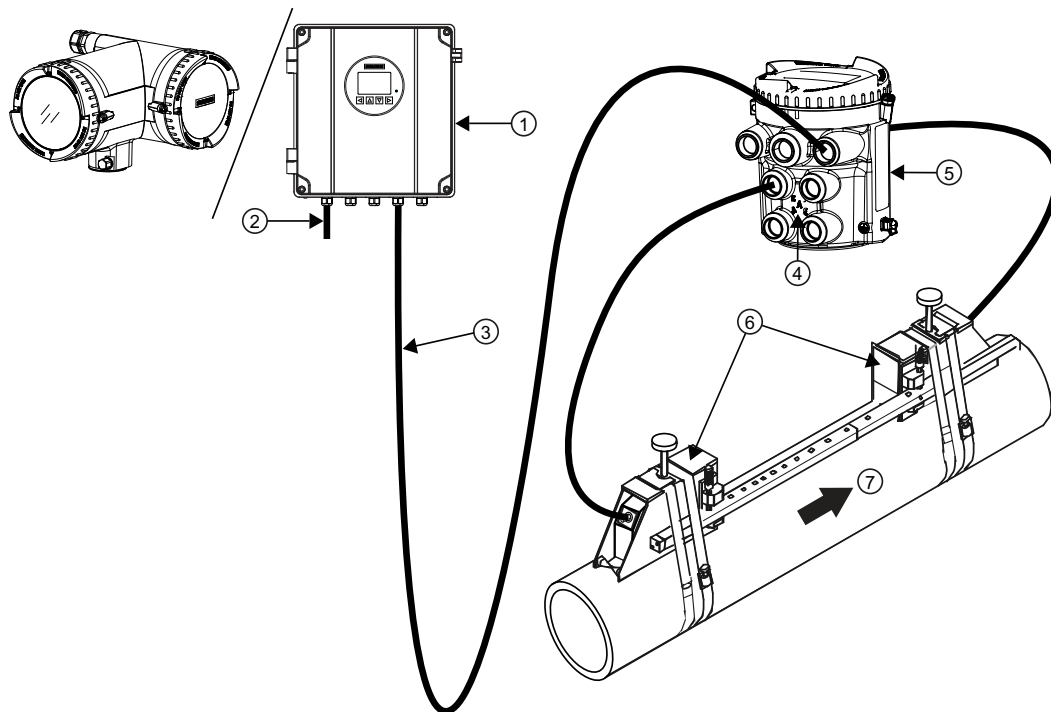

Wall mount transmitter overview with external DSL, example for FSS200

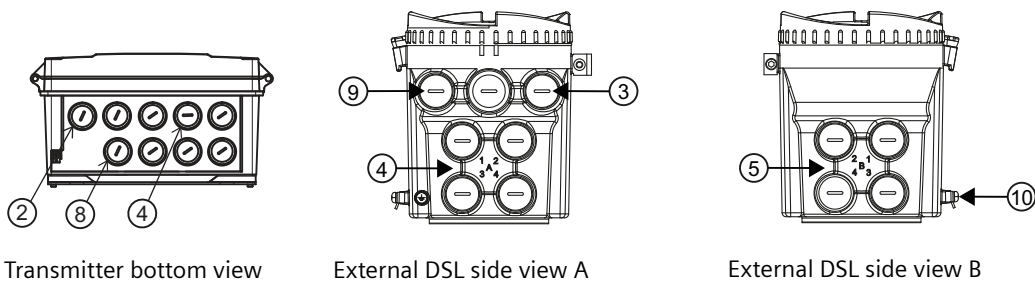

- |   |                                  |
|---|----------------------------------|
| ① FST030 wall mount or industrial enclosure transmitter         | ⑥ Sensors                        |
| ② Power cable   | ⑦ Flow direction                 |
| ③ Cable connection between FST030 and external DSL, up to 150 m | ⑧ Ports for I/O, Communications  |
| ④ Path 1-4 upstream (A)   | ⑨ Ports for analog input or RTDs |
| ⑤ Path 1-4 downstream (B)                                       | ⑩ Protective earth               |

## 3.6 Installation Instructions

### 3.6.1 Industrial enclosure

#### 3.6.1.1 Mounting on wall

1. Prepare holes with aid of the mounting bracket, see Mounting bracket dimensions (Page 114).
2. Fasten mounting bracket with black cushion pad to wall (torque 10 Nm).

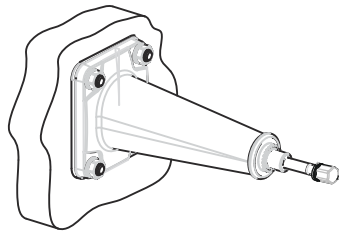

#### 3.6.1.2 Mounting on pipe

1. Mount mounting bracket with cushion pad on pipe using fastening brackets/U-bolts and supplied pipe adaptor.

---

**Note**

U-bolts and other miscellaneous hardware are not supplied with the flowmeter.

---

2. Tighten nuts (torque: 10 Nm).

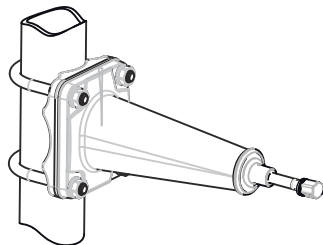

### 3.6.1.3 Mounting the transmitter

#### M12 digital cable connection

1. Remove locking cap from mounting bracket.
2. Mount transmitter on mounting bracket taking care that the flutes on the mating faces are correctly engaged.

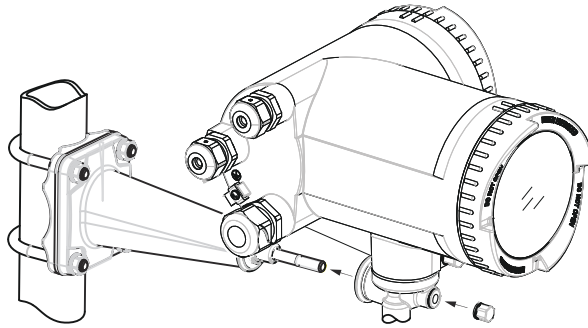

3. Firmly tighten locking cap on mounting bracket (torque: 25 Nm).

### 3.6.1.4 Turning the transmitter

#### Horizontal rotation

1. Unscrew cap from lock screw.
2. Loosen lock screw at transmitter pedestal using 5 mm Allen key.
3. Carefully rotate transmitter into desired position.

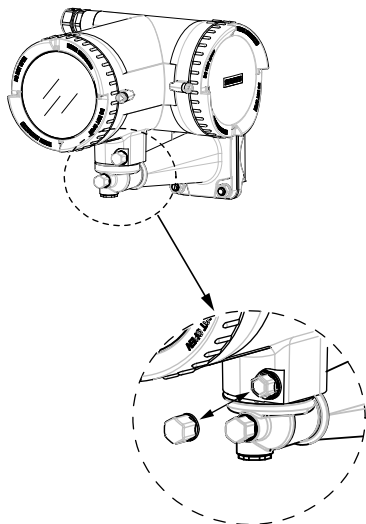

4. Firmly tighten lock screw (torque: 10 Nm).
5. Replace cap onto lock screw (torque: 10 Nm).

### Vertical rotation

1. Loosen locking cap at end of mounting bracket by three turns.
2. Carefully loosen and rotate transmitter into desired position (15° steps).

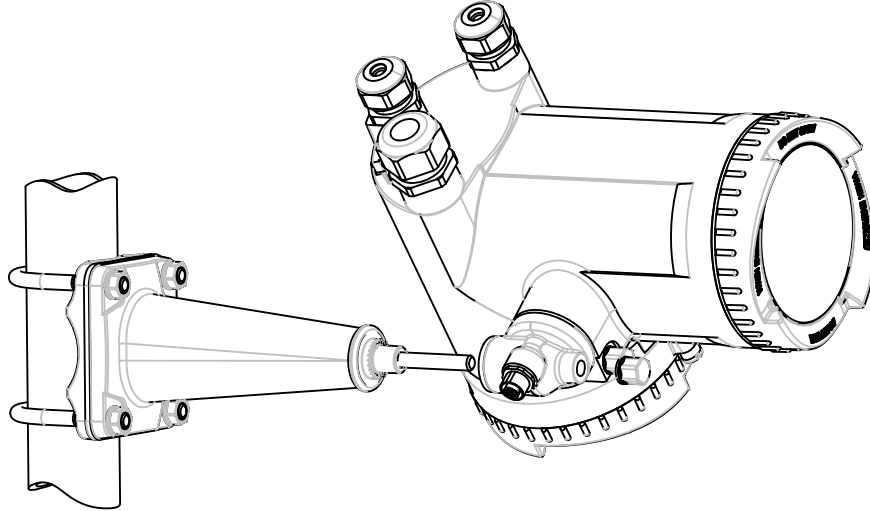

3. Firmly tighten locking cap (torque: 25 Nm).

#### 3.6.1.5 Turning the local display

The local display can be turned in steps of 30° in order to optimize the viewing angle.

1. Remove lid lock screw of display cover.
2. Remove display cover.
3. Use a small screwdriver or blade to loosen the three retaining clips within the transmitter.
4. Carefully pull out local display.
5. Turn display into desired position.

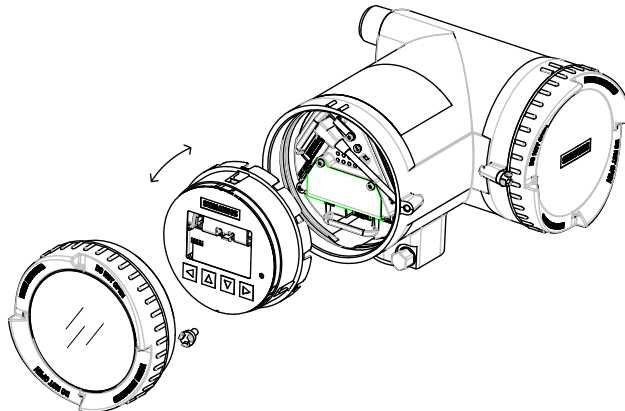

3.6 Installation Instructions

6. Carefully push display back into enclosure. Use a small screwdriver or blade to open the three retaining clips within the transmitter when pushing the display back into place.

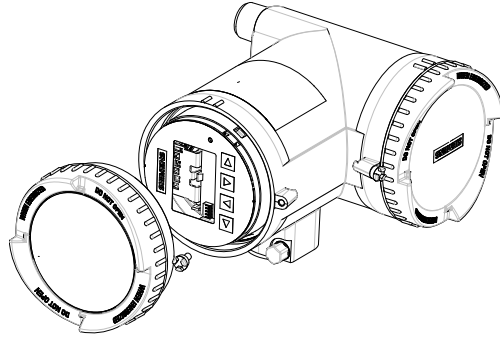

7. Remove O-ring from lid.
8. Reinstall display cover until mechanical stop. Wind back lid by one turn.
9. Mount O-ring by pulling it over the display cover and turn display cover until you feel friction from the O-ring on both sides. Wind display cover further by one quarter of a turn to seal on the O-ring.
10. Reinstall and tighten lid lock screw.

3.6.2 Wall mount enclosure

<b>⚠ CAUTION</b>
<b>Opening lid</b>
Care must be taken when opening the lid to avoid the lid falling.

**Note**

**Mounting screws are not included**

You will need four screws, able to support at least 25 kg (55 lbs).



1. Prepare holes for the four screws. Screw head diameter: max. 13.5 mm; screw shaft diameter: max. 6 mm.

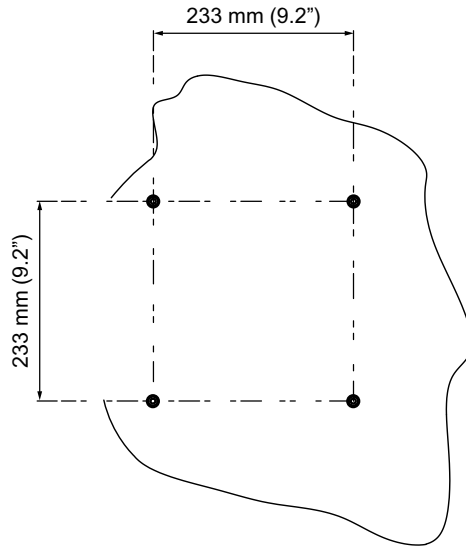

2. Mount transmitter and tighten screws.

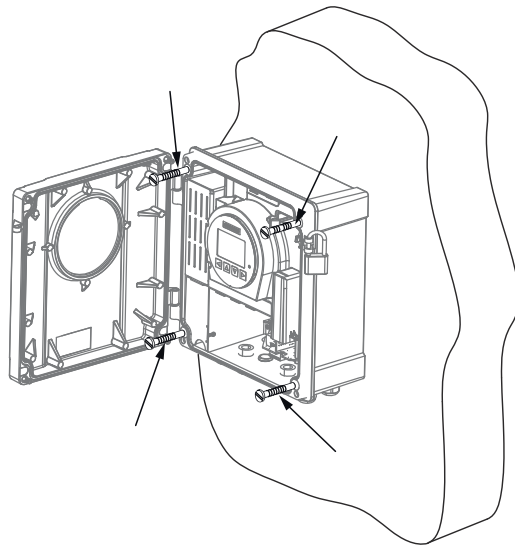

---

**Note**

**Mounting on pipe or in panel**

For mounting on pipe or on a panel, see the installation instructions for AUTOHOTSPOT, which are provided with the optional pipe/panel mount kit.

---

### 3.6.3 Mounting the external DSL

#### Mounting on wall

1. Remove mounting bracket from DSL.
2. Mount bracket on a wall using four screws.

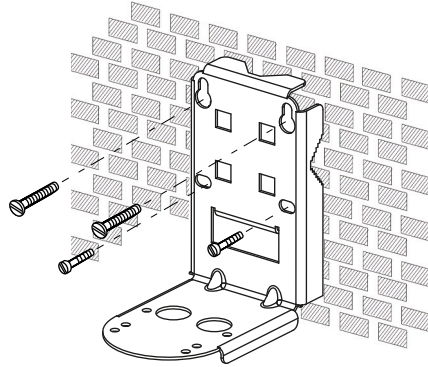

Figure 3-3 Mounting bracket on wall

3. Mount DSL on mounting bracket using four screws.

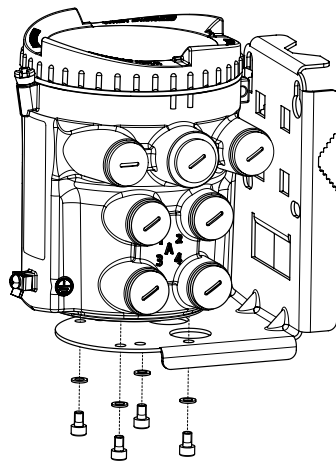

Figure 3-4 Mounting DSL to mounting bracket

#### Mounting on pipe

The external DSL can be mounted either using Pipe mount kit (available only for pipes sized 2" in diameter) or hose clips / duct straps.

### Mounting on pipe using hose clips or duct tapes

1. Remove mounting bracket from DSL.
2. Mount bracket on a horizontal or a vertical pipe using ordinary hose clips or duct straps.

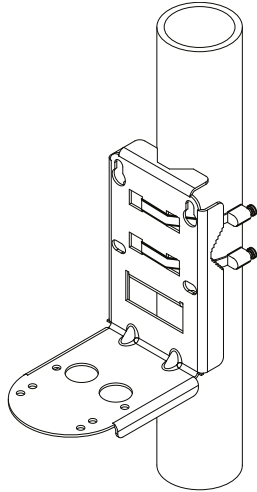

Figure 3-5 Mounting bracket on vertical pipe

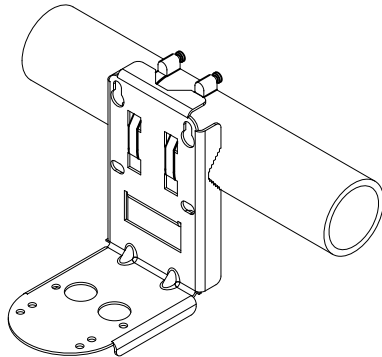

Figure 3-6 Mounting bracket on horizontal pipe

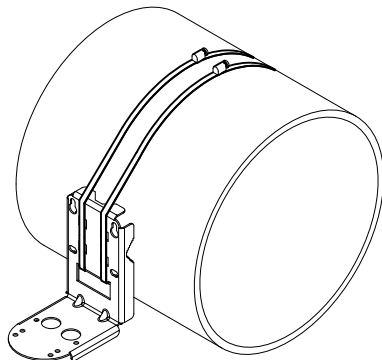

Figure 3-7 Mounting bracket on big horizontal pipe

3. Mount DSL on mounting bracket using four screws.

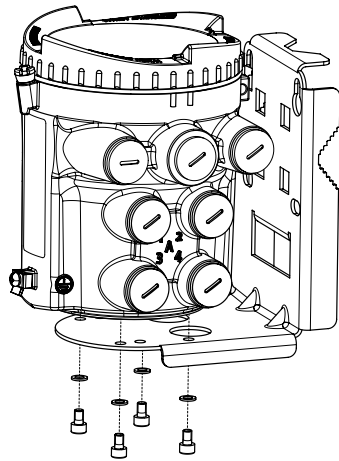

Figure 3-8 Mounting DSL to mount bracket

## 3.7 Installing sensors in Reflect mount

### Reflect mount - Sensor installation using mounting frames and spacer bar

1. Use the Sensor settings Wizard setup procedure to program the meter for application parameters such as pipe size, liquid type, and sensor size. Once entered the transmitter will return a spacing index number appropriate for the application.
2. Using the supplied space bar, set the distance between the sensors according to the spacing index number provided by transmitter. The spacing index provides the correct distance between the sensors based on the pipe size given.

**Before continuing refer to the Reflect mount installation diagram example below.**

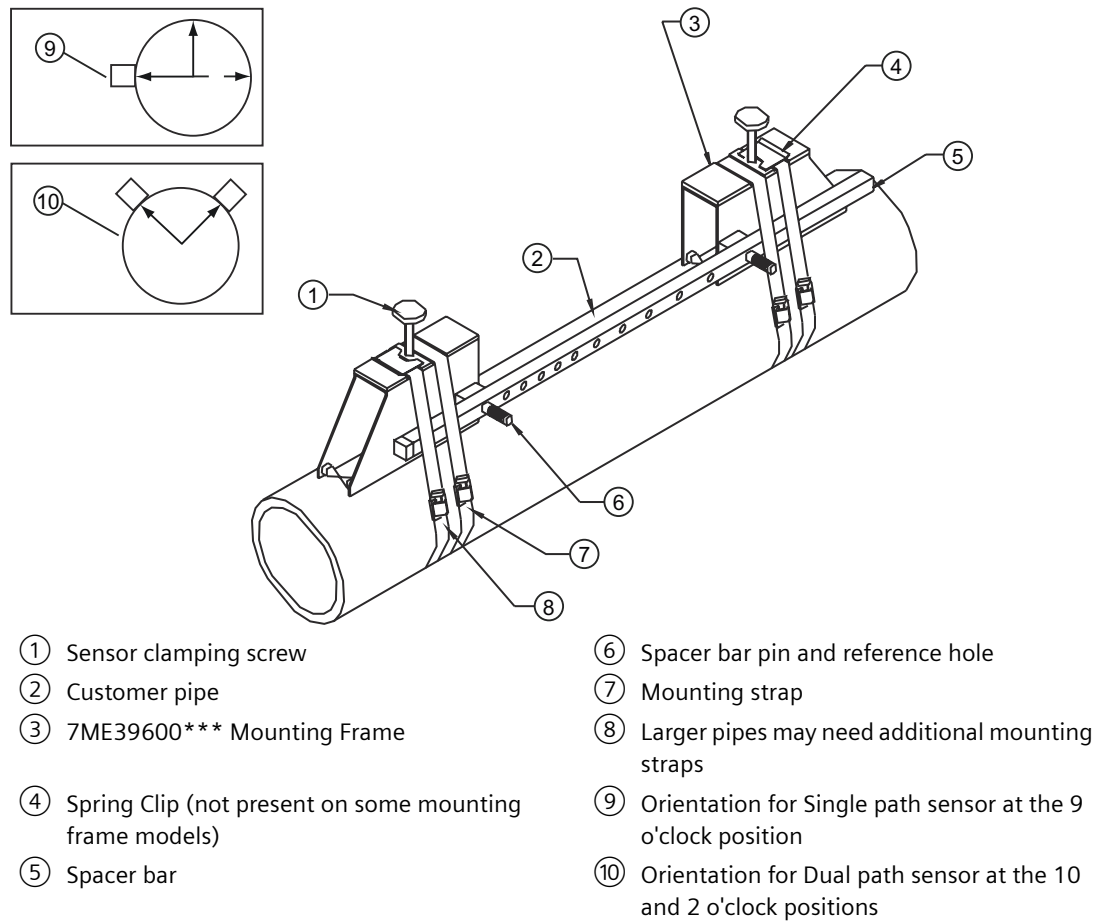

Figure 3-9 Reflect mount

**Note**

**Additional mounting options**

For additional mounting options see FSS200 installation manual

### 3.8 Incorrect mounting

<b>NOTICE</b>
<b>Incorrect mounting</b>
The device can be damaged, destroyed, or its functionality impaired through improper mounting.
<ul style="list-style-type: none"> <li>• Before installing ensure there is no visible damage to the device.</li> <li>• Mount the device using suitable tools. See operating instructions.</li> </ul>

## 3.9 Disassembly

 **WARNING**

**Incorrect disassembly**

The following risks may result from incorrect disassembly:

- Injury through electric shock
- Risk through emerging media when connected to the process
- Risk of explosion in hazardous area

In order to disassemble correctly, observe the following:

- Before starting work, make sure that you have switched off all physical variables such as pressure, temperature, electricity etc. or that they have a harmless value.
- If the device contains hazardous media, it must be emptied prior to disassembly. Make sure that no environmentally hazardous media are released.
- Secure the remaining connections so that no damage can result if the process is started unintentionally.

# Connecting

## 4.1 Basic safety notes

** WARNING****Unsuitable cables, cable glands and/or plugs**

Risk of explosion in hazardous areas.

- Use only cable glands/plugs that comply with the requirements for the relevant type of protection.
- Tighten the cable glands in accordance with the torques specified in Connecting the sensor cables (internal DSL only) (Page 39).
- Close unused cable inlets for the electrical connections.
- When replacing cable glands, only use cable glands of the same type.
- After installation, check that the cables are seated firmly.

** WARNING****Hazardous contact voltage**

Risk of electric shock in case of incorrect connection.

- For the electrical connection specifications, refer to the information in Technical specifications (Page 97).
- At the mounting location of the device observe the applicable directives and laws for installation of electrical power installations with rated voltages below 1000 V.

**NOTICE****Condensation in the device**

Damage to device through formation of condensation if the temperature difference between transportation or storage and the mounting location exceeds 20 °C (36 °F).

- Before taking the device into operation, let the device adapt for several hours in the new environment.

 <b>WARNING</b>
<b>Missing PE/ground connection</b>
Risk of electric shock.
Depending on the device version, connect the power supply as follows:
<ul style="list-style-type: none"><li>• <b>Power plug:</b> Ensure that the used socket has a PE/ground conductor connection. Check that the PE/ground conductor connection of the socket and power plug match each other.</li><li>• <b>Connecting terminals:</b> Connect the terminals according to the terminal connection diagram. First connect the PE/ground conductor.</li></ul>

### 4.1.1 Spark ignition hazard

 <b>WARNING</b>
<b>Spark Ignition hazard</b>
Do not connect an external supply to I/O configured as active.

<b>NOTICE</b>
<b>Ambient temperature too high</b>
Damage to cable sheath.
<ul style="list-style-type: none"><li>• At an ambient temperature <math>\geq 60\text{ }^{\circ}\text{C}</math> (<math>140\text{ }^{\circ}\text{F}</math>), use heat-resistant cables suitable for an ambient temperature at least <math>20\text{ }^{\circ}\text{C}</math> (<math>36\text{ }^{\circ}\text{F}</math>) higher.</li></ul>

 <b>WARNING</b>
<b>Improper power supply</b>
Risk of explosion in hazardous areas as result of incorrect power supply.
<ul style="list-style-type: none"><li>• Connect the device in accordance with the specified power supply and signal circuits. The relevant specifications can be found in the certificates, in Technical specifications (Page 97) or on the nameplate.</li></ul>



** WARNING****Lack of equipotential bonding**

Risk of explosion through compensating currents or ignition currents through lack of equipotential bonding.

- Ensure that the device is potentially equalized
- The cable cross-section of the equipotential bonding cable must be greater than or equal to the connecting cable of the electronics

** WARNING****Unprotected cable ends**

Risk of explosion through unprotected cable ends in hazardous areas.

- Protect unused cable ends in accordance with IEC/EN 60079-14.

** WARNING****Improper laying of shielded cables**

Risk of explosion through compensating currents between hazardous area and the non-hazardous area.

- Shielded cables that cross into hazardous areas should be grounded only at one end.
- If grounding is required at both ends, use an equipotential bonding conductor.

** WARNING****Insufficient isolation of intrinsically safe and non-intrinsically safe circuits**

Risk of explosion in hazardous areas.

- When connecting intrinsically safe and non-intrinsically safe circuits ensure that isolation is carried out properly in accordance with local regulations for example IEC 60079-14.
- Ensure that you observe the device approvals applicable in your country.

** WARNING****Incorrect conduit system**

Risk of explosion in hazardous areas as result of open cable inlet or incorrect conduit system.

- In the case of a conduit system, mount a spark barrier at a defined distance from the device input. Observe national regulations and the requirements stated in the relevant approvals.

 <b>WARNING</b>
<b>Connecting or disconnecting device in energized state</b>
Risk of explosion in hazardous areas.
<ul style="list-style-type: none"><li>• Connect or disconnect devices in hazardous areas only in a de-energized state.</li><li>• Install a suitable switch-off device.</li></ul>
<b>Exceptions:</b>
<ul style="list-style-type: none"><li>• Devices having the type of protection "Intrinsic safety Ex i" may also be connected in energized state in hazardous areas.</li></ul>

 <b>WARNING</b>
<b>Energized devices</b>
Risk of electric shock or explosion.
When energized the device may be opened by qualified personnel only.

 <b>WARNING</b>
<b>Mains supply from building installation overvoltage category 2</b>
A switch or circuit breaker (max. 15 A) must be installed in close proximity to the equipment and within easy reach of the operator. It must be marked as the disconnecting device for the equipment.

---

**Note**

**Electromagnetic compatibility (EMC)**

You can use this device in industrial environments, households and small businesses.

Metal enclosures ensure improved electromagnetic protection from high frequency radiation. This protection can be increased by grounding the enclosure.

---

**See also**

Technical specifications (Page 97)

**Note****Improvement of interference immunity**

- Lay signal cables separate from cables with voltages > 60 V.
- Use cables with twisted wires.
- Keep device and cables in distance to strong electromagnetic fields.
- Use shielded cables to guarantee the full specification according to HART.
- Connect a load resistor of at least 230  $\Omega$  in series in the signal circuit in order to guarantee fault-free HART communication. When power supply isolators are used for SITRANS HART transmitters, a load resistor is already installed in the device.

**⚠ WARNING****Uncovered non-intrinsically safe circuits**

Risk of explosion in hazardous areas or electric shock when working on non-intrinsically safe circuits.

If intrinsically safe and non-intrinsically safe circuits are operated in an enclosure with the type of protection "Increased safety Ex e", the connections of the non-intrinsically safe circuits must be additionally covered.

- Ensure that the cover of the non-intrinsically safe circuits complies with degree of protection IP30 or higher according to IEC/EN 60529.
- Separate connections of the non-intrinsically safe circuits in accordance with IEC/EN 60079-14.

## 4.2 Connecting the sensor cables (internal DSL only)

### Preparing for the connection

1. Loosen the four lid screws.
2. Open the lid.
3. Remove F-connector tool from wall mount enclosure.

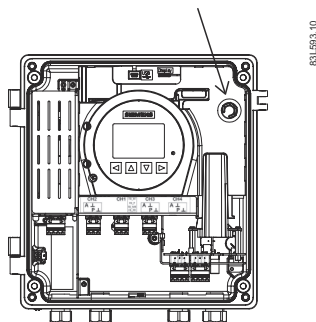
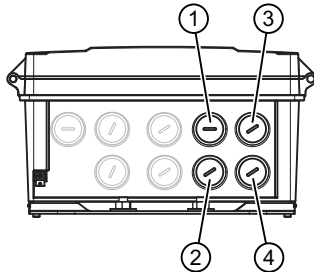

Figure 4-1 F-connector tool location

### Connecting the flow sensor cables

When connecting the sensors it is required for the system to function that the sensor cables are connected correctly. Both sensor cables for each path must be connected to the same port numbers (1A and 1B or 2A and 2B) on the transmitter.



- ① Path 1 - Upstream sensor cable (1A)
- ② Path 1 - Downstream sensor cable (1B)
- ③ Path 2 - Upstream (2A)
- ④ Path 2 - Downstream (2B)

The sensor cables are delivered with a premounted F-connector at the transmitter end.

1. Remove the blind plug from the wall mount enclosure.
2. Slide the cable gland back onto the cable and allow access for the F-connector tool.
3. Place F-connector tool around cable and slide up to engage F-connector nut.
4. Push cable through the gland opening. Ensure that the center lead is aligned with connector port in the transmitter.
5. Tighten the F-connector using the tool until you meet a mechanical stop.

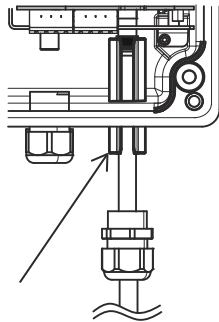

6. Remove the F-connector tool.
  7. Mount and tighten the cable gland.
- Repeat these steps for each sensor cable.

## 4.3 Connecting the sensor cables to the sensor

### Note

The following example is shown in the Reflect mount sensor configuration.

Connect sensor cables to the sensor as follows:

1. Fill connector end with the supplied grease prior to connecting.
2. Apply the supplied grease to the internal threads at the large end of the thread connector.
3. Observing the upstream and downstream orientation (⑥), connect upstream sensor cable (③) from the transmitter port (1A) to the sensor (⑤) and make connection snug.
4. Connect the downstream sensor cable (④) from the transmitter port (1B) to the sensor (⑤) and make connection snug.

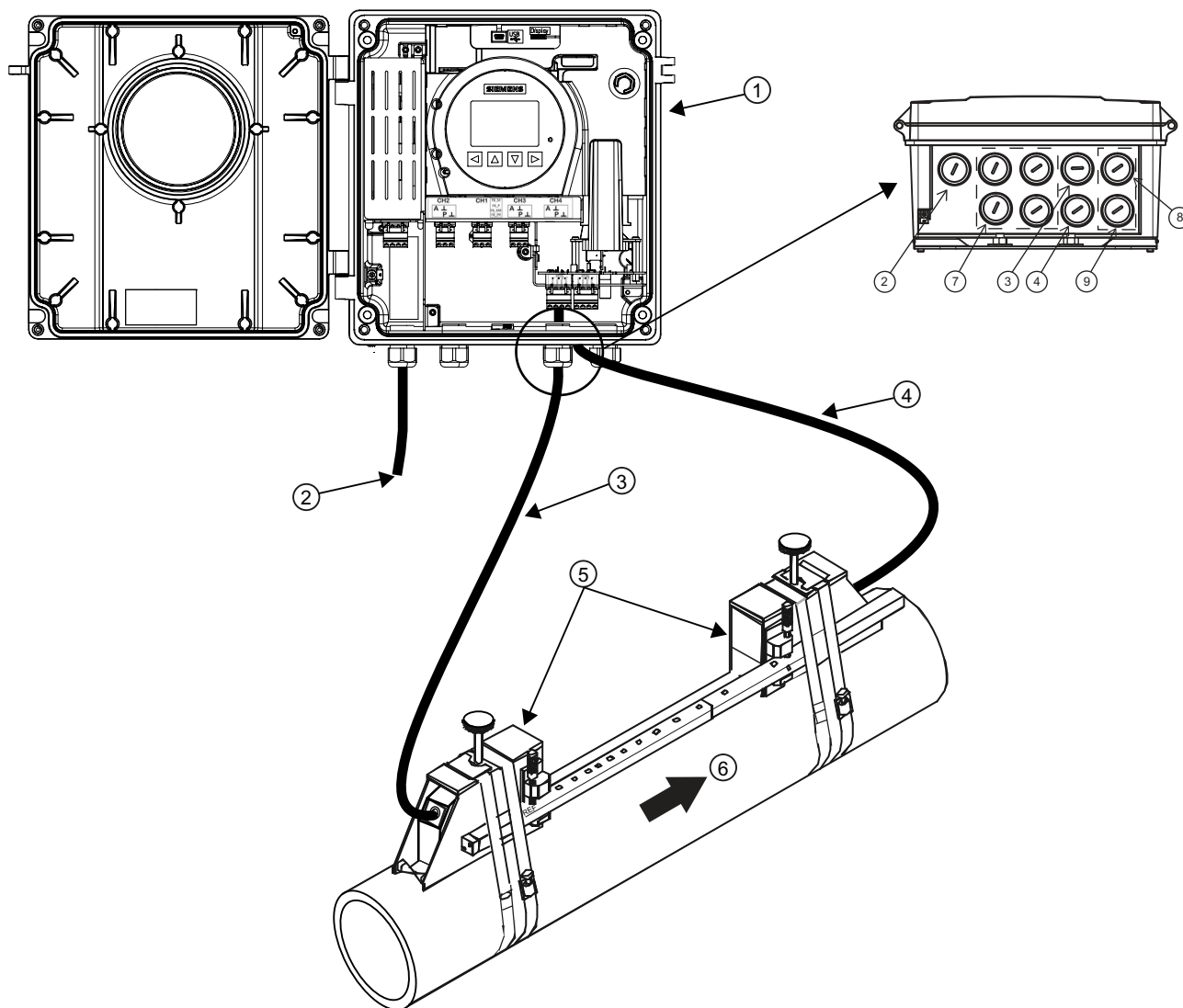

- |   |                                       |
|---|---------------------------------------|
| ① Wall mounted transmitter              | ⑤ Sensors                             |
| ② Power cable                           | ⑥ Flow direction                      |
| ③ Path 1 - Upstream sensor cable (1A)   | ⑦ Ports for I/O, Communications, RTDs |
| ④ Path 1 - Downstream sensor cable (1B) | ⑧ Path 2 - Upstream (2A)              |
|   | ⑨ Path 2 - Downstream (2B)            |

Figure 4-2 Wall mount enclosure with transmitter-to-sensor cable connections

5. Tighten all cable glands to obtain optimum sealing.

## 4.4 HI Precision mount FST030

### Single enclosure Reflect mount wiring

Connect sensor cables to the sensor as follows:

1. Fill connector end with Super Lube prior to connecting.
2. Apply Super Lube to the internal threads at the large end of the thread connector.
3. Observing the upstream and downstream orientation ③, connect upstream sensor cable ④ from transmitter port (1A) and make connection snug.

4. Connect downstream sensor cable ② from transmitter port (1B) and make connection snug.

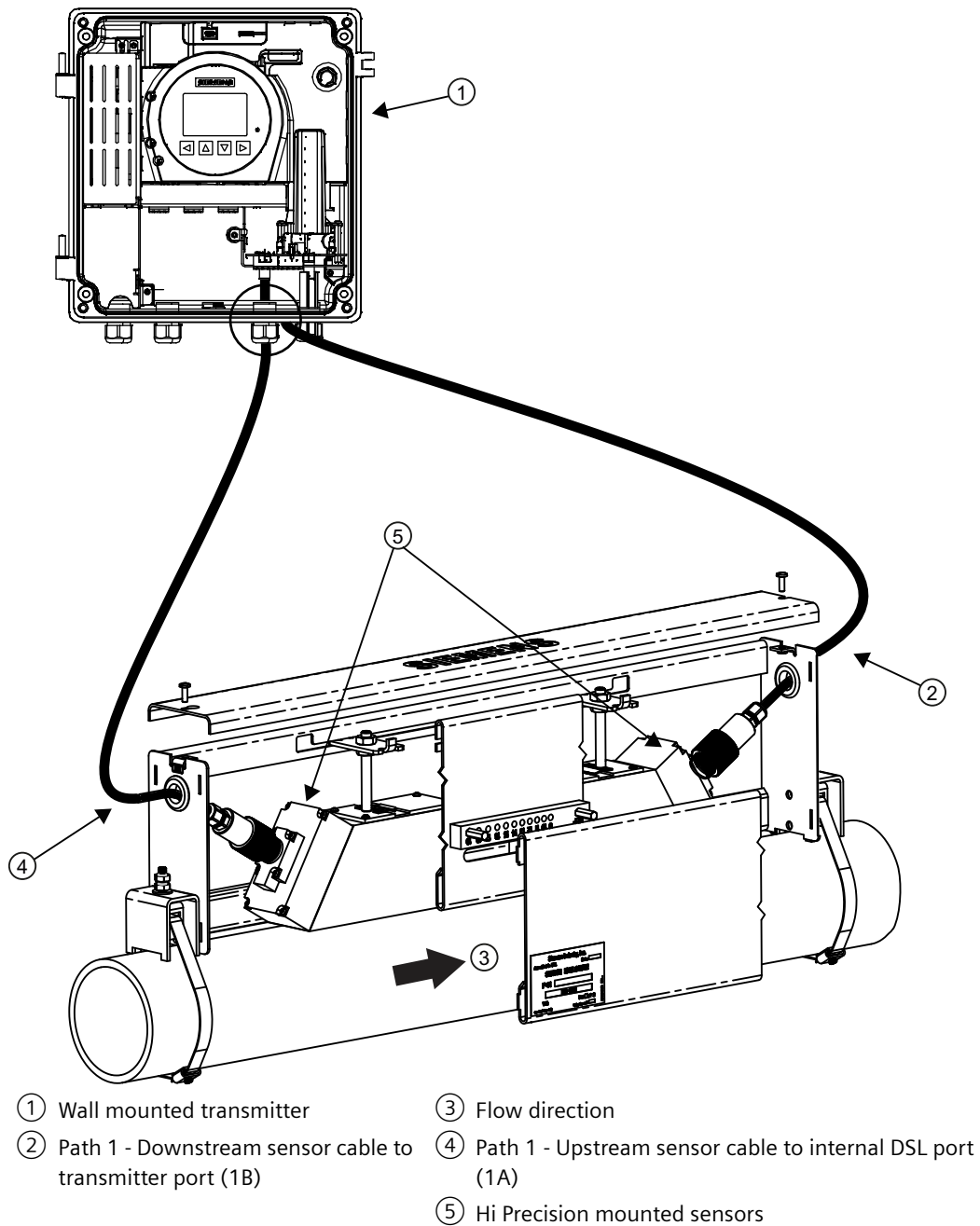

Figure 4-3 Hi Precision Reflect mount single enclosure wiring

5. Tighten all cable glands to obtain optimum sealing.

**Dual enclosure Reflect mount wiring**

Referring to the Hi Precision single enclosure reflect mount figure above, connect the Hi Precision mount reflect Dual enclosure sensor cables from the transmitter ports as follows:

1. Observing the upstream and downstream orientation ③, connect sensor cables from transmitter ports.
2. Tighten all cable glands to obtain optimum sealing.
3. Refer to transmitter FST030 Operating Instructions to program transmitter.

**Dual enclosure direct mount wiring**

Connect sensor cables to the DSL and transmitter as follows:

1. Fill connector end with Super Lube prior to connecting.
2. Apply Super Lube to the internal threads at the large end of the thread connector.
3. Observing the upstream and downstream orientation ③, connect upstream sensor cable ⑤ from transmitter port (1A) and make connection snug.



4. Connect downstream sensor cable ② from transmitter port (1B) and make connection snug.

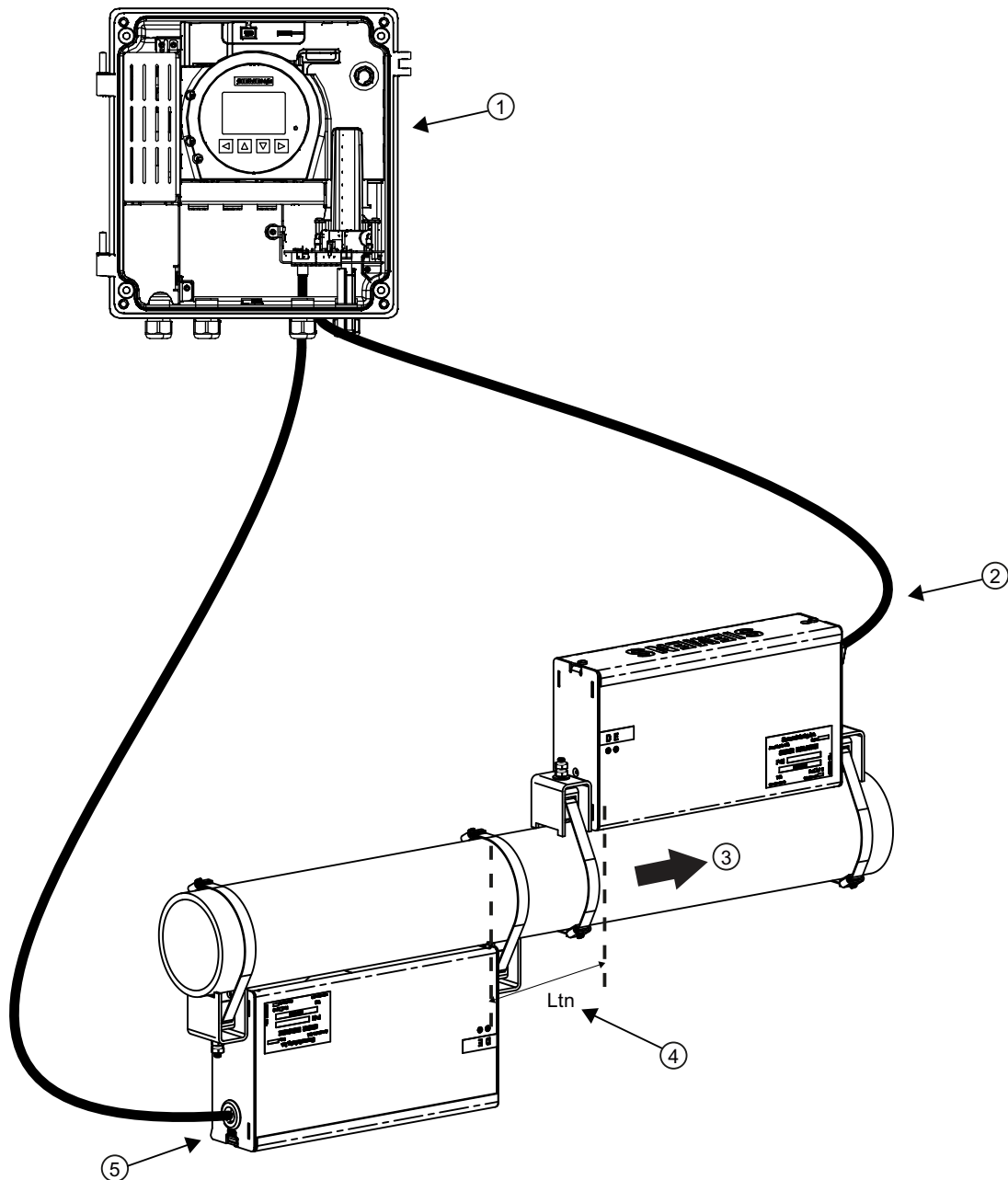

- |   |  |
|---|--|
| ① Wall mounted transmitter                                  | ③ Flow direction   |
| ② Path 1 - Downstream sensor cable to transmitter port (1B) | ④ Ltn (spacing distance between sensors)                   |
|   | ⑤ Path 1 - Upstream sensor cable to internal DSL port (1A) |

Figure 4-4 HI Precision Direct mount Dual enclosure sensor wiring

5. Tighten all cable glands to obtain optimum sealing.  
6. Refer to transmitter FST030 Operating Instructions to program transmitter.

## 4.5 Connecting the external DSL

For configurations with external DSL first prepare the connections in the external DSL enclosure. Afterwards proceed with the connections in the FST030 transmitter enclosure.

In the external DSL it is possible to connect sensor cables from up to four measurement paths.

Furthermore, external measurements from up to two optional devices can be connected: 4 to 20 mA current input (passive) and/or resistive temperature device (RTD)

The DSL wiring comprises the following steps:

1. Preparing for the external DSL connections (Page 46)
2. Connecting the sensor cables (Page 47)
3. Connecting optional devices (Page 49)
4. Connecting the SSL cable (Page 52)
5. Finishing the DSL connection (Page 54)

### 4.5.1 Preparing for the external DSL connections

1. Remove lid from DSL
2. Remove F connector tool from DSL and use it to connect the sensor cables.

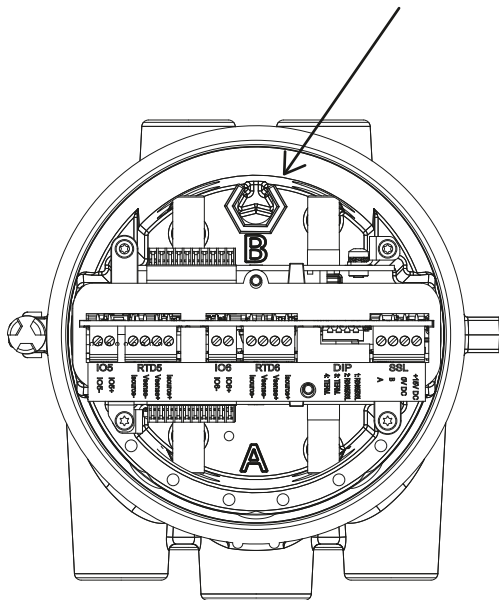

## 4.5.2 Connecting the sensor cables

When connecting the sensor to the DSL make sure that you connect the sensor cables for each path to the corresponding numbers on the DSL (A and B).

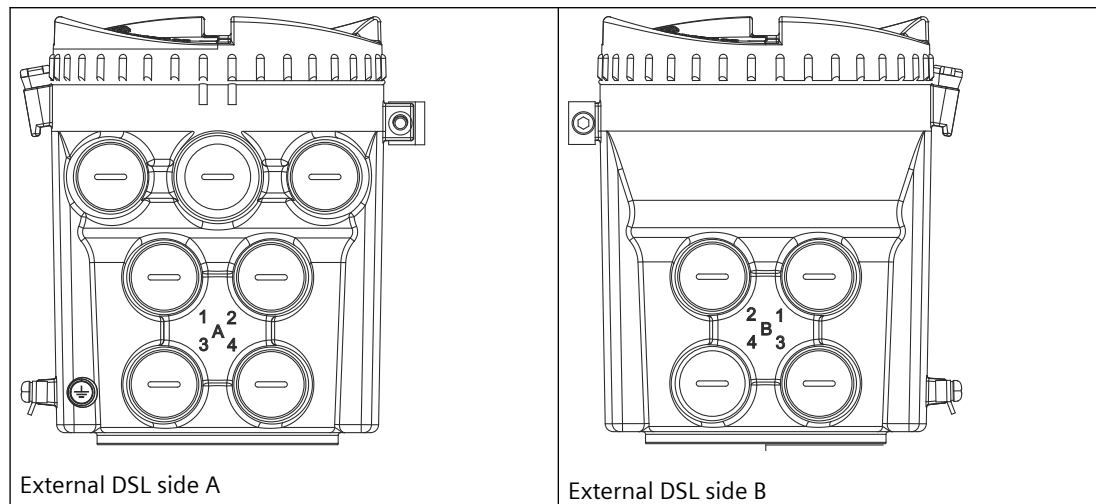

The sensor cables are delivered with a pre-mounted F-connector at transmitter end.

1. Remove blind plug from external DSL enclosure.
2. Slide the cable gland back onto the cable and allow access for the F-connector tool.
3. Place F-connector tool around cable and slide up to engage F-connector nut.
4. Push cable through gland opening. Ensure that center lead is aligned with connector port in external DSL.
5. Tighten F-connector using tool until you meet mechanical stop.

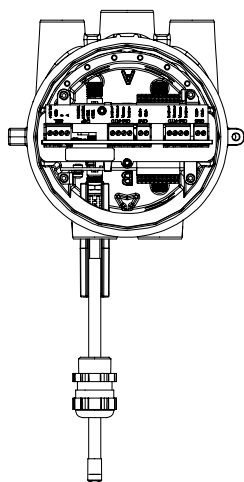

6. Remove F-connector tool.
  7. Mount and tighten cable gland.
- Repeat these steps for each sensor cable.

### 4.5.3 Channel 5 and 6 input configuration

---

**Note**

**Connection of optional devices**

The external DSL provides the option of connecting two additional devices to channels 5 and 6. Do not connect two devices to one channel.

---

**Note**

**Analog input on channel 6**

Hardware version 2 and below does not support analog input on channel 6.

---

### Input configuration

Connect the two, three or four wires to the terminal block as shown below. Short-circuit terminals as required.

---

**Note**

**The terminal connector is detachable**

For easier access unplug the terminal connector. After connecting the wires, plug the terminal connector back in.

---

**Note**

**RTD shield grounding**

Make sure that the RTD cable shield is properly grounded. Consult the FSS200 Installation Manual on how to ground the RTD cable shield.

---

Table 4-1 Channels 5 and 6 configuration

Configuration	Software configuration	Connection diagram
Input Passive	Current input	
RTD input	Pt100 Pt500 Pt1000	<p>--- Short</p> <p>2-wire RTD configuration</p>
		<p>--- Short</p> <p>3-wire RTD configuration</p>
		<p>4-wire RTD configuration</p>

#### 4.5.4 Connecting optional devices

##### Connecting 4 to 20 mA current input cable (passive)

###### Note

###### Connection of optional devices

The DSL provides the option of connecting two additional devices to channels 5 and 6. Do not connect two devices to one channel.

4.5 Connecting the external DSL

Perform the following steps for each current input cable.

1. Remove cap and ferrule from cable gland and slide onto cable.
2. Remove one of the blind plugs (① or ②) and fit cable gland.

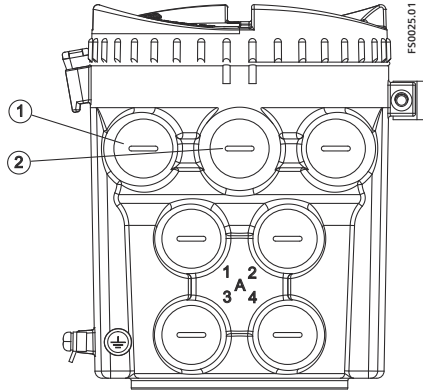

3. Push cable through gland opening.
4. Ground current input cable shield using the ground clamp inside the external DSL.
5. Connect the two wires to two-terminal block (Ch5+ and Ch5-, or Ch6+ and Ch6-).

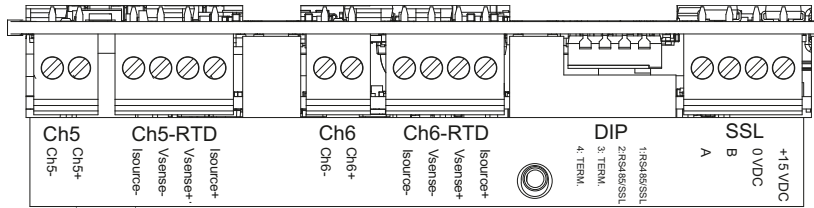

6. Assemble and tighten cable gland.

Connecting RTD cable

Perform the following steps for each RTD cable.

1. Remove cap and ferrule from cable gland and slide onto cable.
2. Remove one of the blind plugs (① or ②) and fit cable gland.

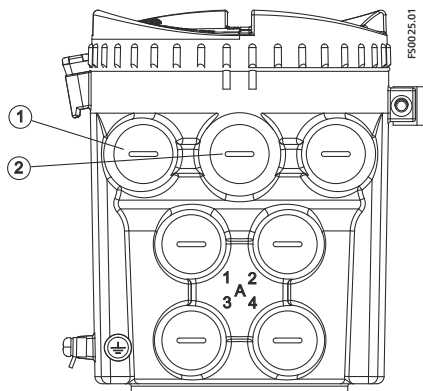

3. Push cable through gland opening.

4. Attach an RTD cable crimp lug on the blue wire (5) of the cable by using a crimp tool or equivalent.

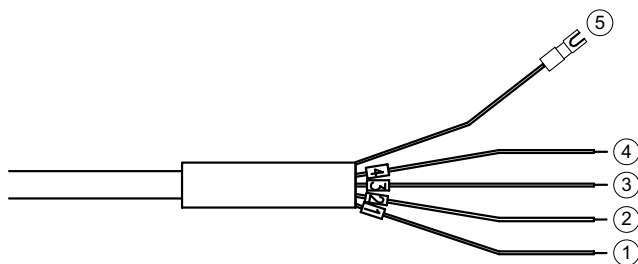

- |                             |                          |
|-----------------------------|--------------------------|
| ① Wire to Isource + (black) | ④ Wire to Vsense - (red) |
| ② Wire to Vsense + (white)  | ⑤ Wire to ground (blue)  |
| ③ Wire to Isource - (green) |                          |

5. Ground the RTD cable shield in the external DSL (7) by sliding the crimp lug on wire (5) onto one of the installed strain reliefs screws (8).

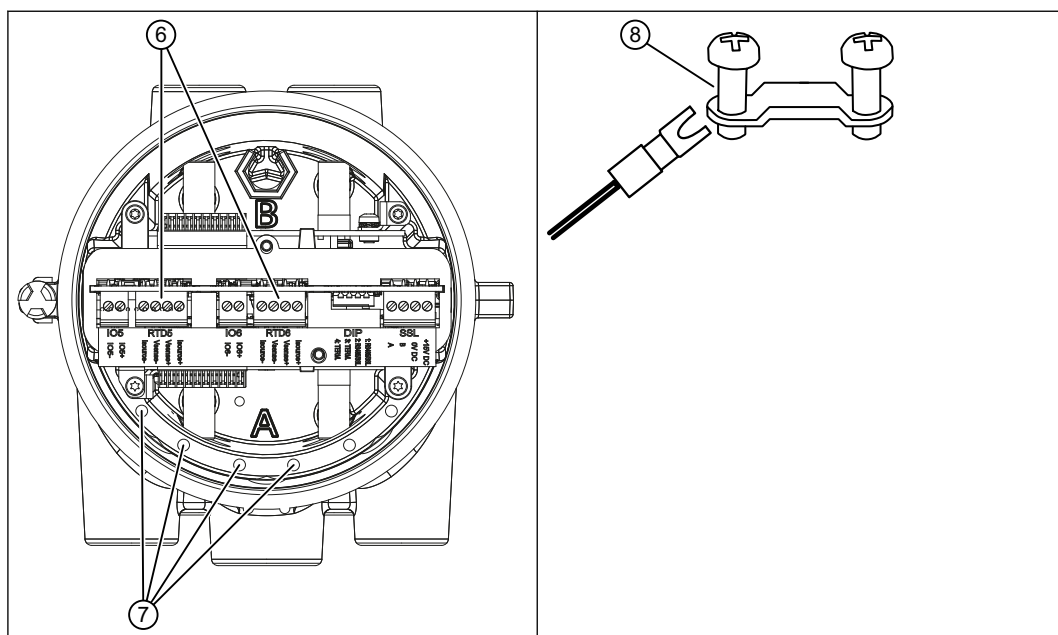

4.5 Connecting the external DSL

- Connect the two, three or four wires to four-terminal block (Ch5-RTD or Ch6-RTD) ⑥. Short-circuit terminals as required.

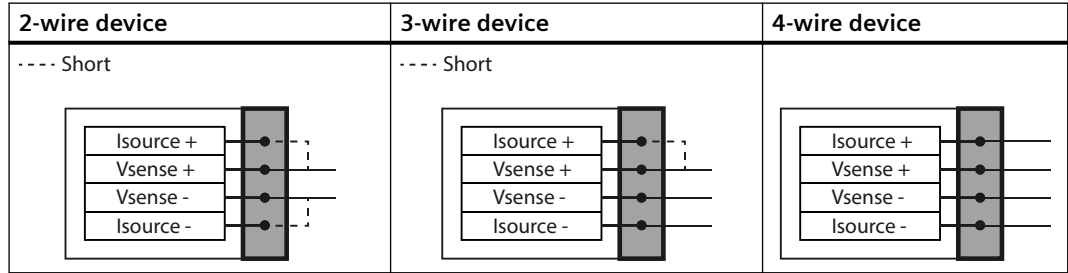
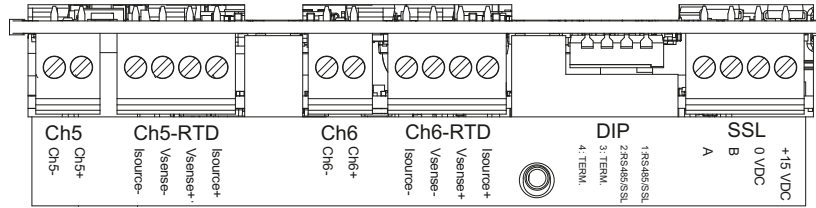

- Assemble and tighten cable gland.

### 4.5.5 Connecting the SSL cable

#### M12 connector version

The SSL cable is provided with M12 style stainless steel plugs.

The cable shield is physically and electrically terminated within the body of the plug.

**Note**

Never pull the cable by the plug - only by the cable itself.

- Connect DSL using the supplied 4-wire cable with M12 connectors to both the external DSL and the transmitter.

**Note**

**Grounding**

The SSL cable shield is only mechanically connected to the grounding terminal (PE), when the M12 plug is correctly tightened.



### M20 connector version

1. Prepare SSL cable by stripping it at both ends.

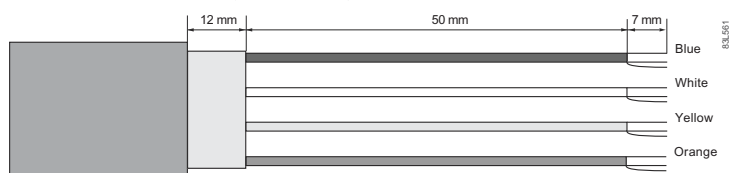
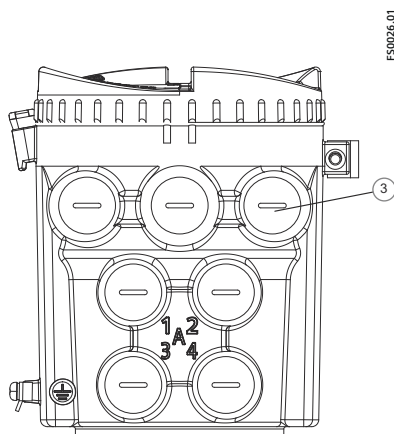
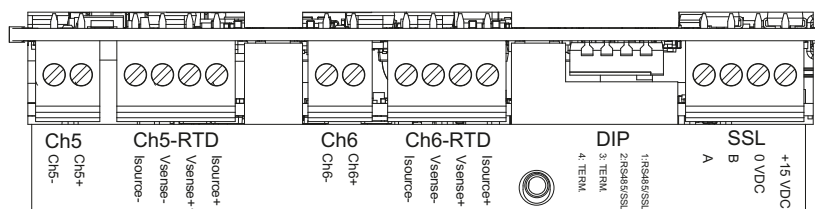

Figure 4-5 Cable end

2. Remove cap and ferrule from cable gland and slide onto cable.
3. Remove blind plug (③) and fit cable gland.



4. Push cable through gland opening.
5. Connect the four wires according to list below.



Terminal connector	Description	Wire color
SSL	+15 V DC	Orange
	0 V DC	Yellow
	B	White
	A	Blue

6. Assemble and tighten cable gland.

### 4.5.6 Finishing the DSL connection

1. Place F connector tool in DSL.
2. In case of Ex, remove all plastic blind plug caps and mount Ex rated cable glands or Ex rated blind plugs in unused cable entries.  
To ensure IP rating, remove caps and mount appropriate cable glands and blind plugs in unused cable entries.  
Firmly tighten cable glands.
3. Check individual wire installation by tugging firmly.
4. Remove O-ring from lid.
5. Reinstall lid and screw in until mechanical stop. Wind back lid by one turn.
6. Mount O-ring by pulling it over the lid and tighten lid cover until you feel friction from the O-ring on both sides. Wind lid further by one quarter of a turn to seal on the O-ring.
7. Ensure that moisture does not penetrate to inside of DSL enclosure by creating a drip loop (bend cables downward) immediately before cable glands.

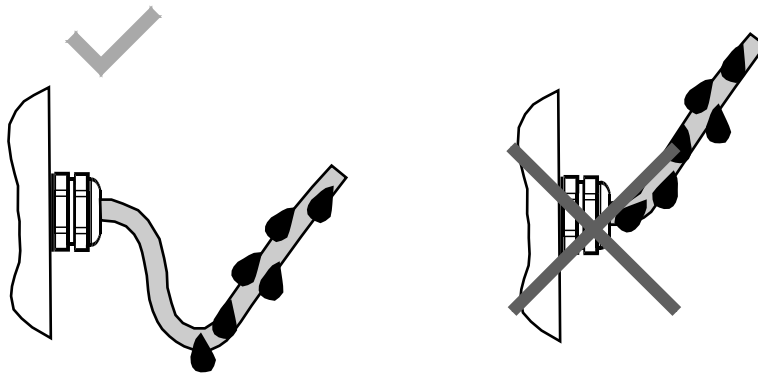

---

#### Note

##### Protection class

The DSL is IP68 only if the lid is properly mounted and all M20 holes are closed with appropriate blind plugs or cable glands.

---

## 4.6 Connecting industrial enclosure

### 4.6.1 Preparing industrial enclosure connections

<b>⚠ WARNING</b>
<b>Access to terminal compartment</b>
As long as the device is energized, the lid of the enclosure on the sensor connection area may only be opened by qualified personnel.
Before removing the terminal cover, the auxiliary power must be switched off from all poles.
Following installation, the terminal cover must be screwed back on again.

1. Remove caps and add blind plugs or cable glands where necessary.

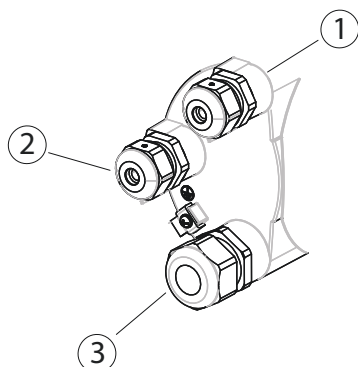

- ① Input/output connection (channels 2 to 4)
- ② Power supply connection
- ③ Current output/communication outputs (channel 1)

2. Remove lid lock screw for terminal connections lid.
3. Remove lid for terminal connections.

A label showing the configuration is placed at the back of the terminal connections lid.



HW configuration	SW configuration	Terminals															
		Power supply			Ch1				Ch2			Ch3			Ch4		
Power supply		1	2	3	4	5	6	7	8	9	10	11	12	13	14	15	16
Channel 1 HART	Current output HART			Ⓢ	Active/+	Active/ -											
					In	Passive/+	Passive/-										
Channel 1 MODBUS					+ (B)	- (A)											
							Out										
Channel 1 PROFIBUS					+ (B)	- (A)											
							Out										
Channel 2 output	Current, Frequency, Pulse and Status						+ (B)	- (A)		Active/+	Active/ -						
										Passive/+	Passive/-						
Channel 3 & 4 Input and output	Outputs: Current, Frequency, Pulse and Status Inputs: Digital											Active/+	Active/ -		Active/+	Active/ -	
												Passive/+	Passive/-		Passive/+	Passive/-	
Channel 3 & 4 Relay	Status output											NO	NO		NO	NO	
												NC	NC		NC	NC	

Figure 4-7 Terminals/configuration overview

### Ex and non-Ex versions

- For Ex versions active or passive current output is preselected at ordering and cannot be changed.
- Non-Ex versions can be connected as either active or passive.

#### 4.6.1.2 Wiring tool

Use the wiring tool for connecting the cables in the compact enclosure transmitter.

The wiring tool is located in the application terminal compartment.

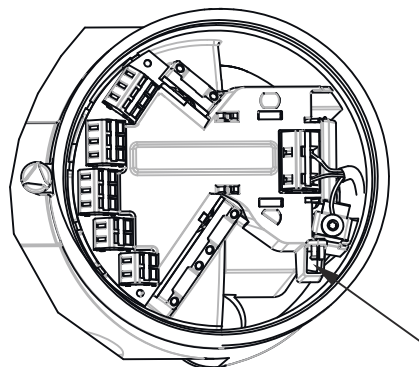
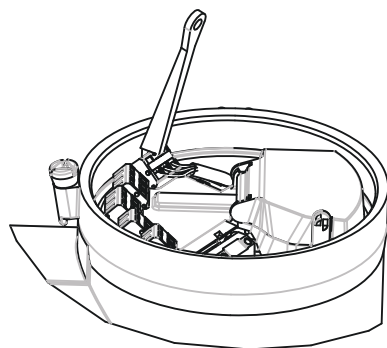

Figure 4-8 Wiring tool location



1. Insert wiring tool hook into receptor slot.
2. Press wiring tool wedge into top slot to spread clamp plates.

- 3. Insert wire.
- 4. Release wiring tool.

### 4.6.2 Connecting the SSL cable (industrial enclosure)

#### M12 connector version

The SSL cable is provided with M12 style stainless steel plugs.  
The cable shield is physically and electrically terminated within the body of the plug.

---

**Note**

Never pull the cable by the plug - only by the cable itself.

---

- 1. Connect the external DSL to the transmitter using the supplied 4-wire cable with M12 connectors.

---

**Note****Grounding**

The SSL cable shield is only mechanically connected to the grounding terminal (PE), when the M12 plug is correctly tightened.

---

#### Wiring sensor and transmitter (sensor terminal compartment)

**A: Prepare the cable by stripping it at both ends.**

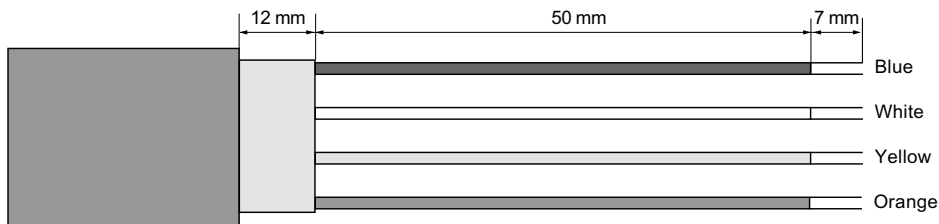

Figure 4-9 Cable end

**B: Connecting SSL cable in terminal compartment**

- 1. Remove lock screw and remove lid.
- 2. Remove one of the blind plugs and fit cable gland.
- 3. Remove cap and ferrule from cable gland and slide onto cable.
- 4. Push cable through open gland; anchor cable with clamp bar.

5. Connect wires to terminals according to list below.

Terminal number	Description	Wire color (Siemens)
1	15 V	Orange
2	0 V	Yellow
3	RS-485 / B	White
4	RS-485 / A	Blue



6. Assemble and tighten cable gland
7. Remove O-ring from lid.
8. Reinstall lid and screw in until mechanical stop. Wind back lid by one turn.
9. Mount O-ring by pulling it over the lid and tighten lid until you feel friction from the O-ring on both sides. Wind lid further by one quarter of a turn to seal on the O-ring.
10. Reinstall and tighten lid lock screw

### 4.6.3 Connecting Modbus

#### Current output Modbus

1. Open enclosure lid.
2. Remove blind plug and fit cable gland.
3. Push cable through open gland and cable path.
4. Restore ferrule and tighten cap to lightly hold cable in place.

- 5. Connect wires to terminals using wiring tool.

**Note**

**The terminal connector is detachable**

For easier access unplug the terminal connector. After connecting the wires, plug the terminal connector back in.

– **Industrial enclosure transmitter**

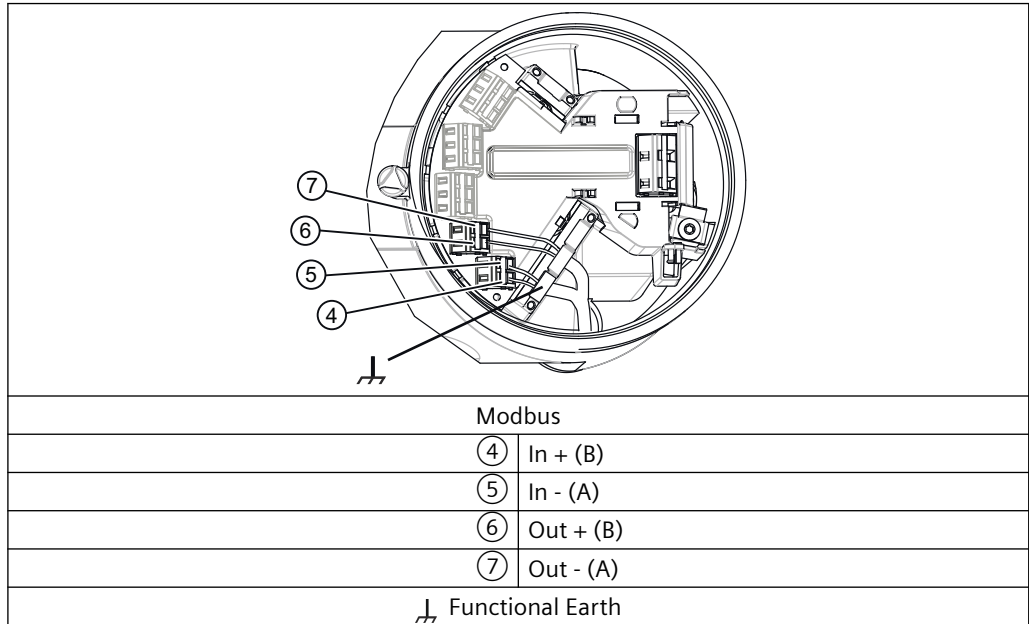

Termination of channel 1. The numbers refer to the terminal layout, see Terminal layout (industrial enclosure) (Page 56).

- 6. Tighten cable gland.

### 4.6.4 Connecting HART

**Note**

**4 to 20 mA output**

It is required to use shielded cables for the pure 4 to 20 mA current output.

**Note**

**HART communication**

It is required by the FieldComm Group (FCG) to use shielded cables for the HART communication.



**Note****Passive channels only**

Channel 1 power supply must be separated from that for channels 2 to 4.

Signal return (or common) can be joined.

---

**Procedure**

1. Remove cap and ferrule from cable gland and slide onto cable.
2. Push cable through open gland and cable path.
3. Restore ferrule and tighten cap to lightly hold cable in place.
4. Signal cable screen is folded back over outer sheath and grounded beneath cable clamp.

4.6 Connecting industrial enclosure

5. Connect wires to terminals using wiring tool.

– Industrial enclosure:

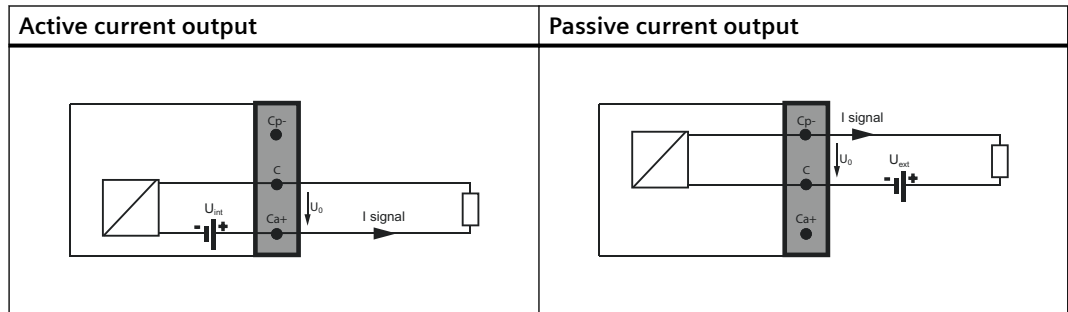
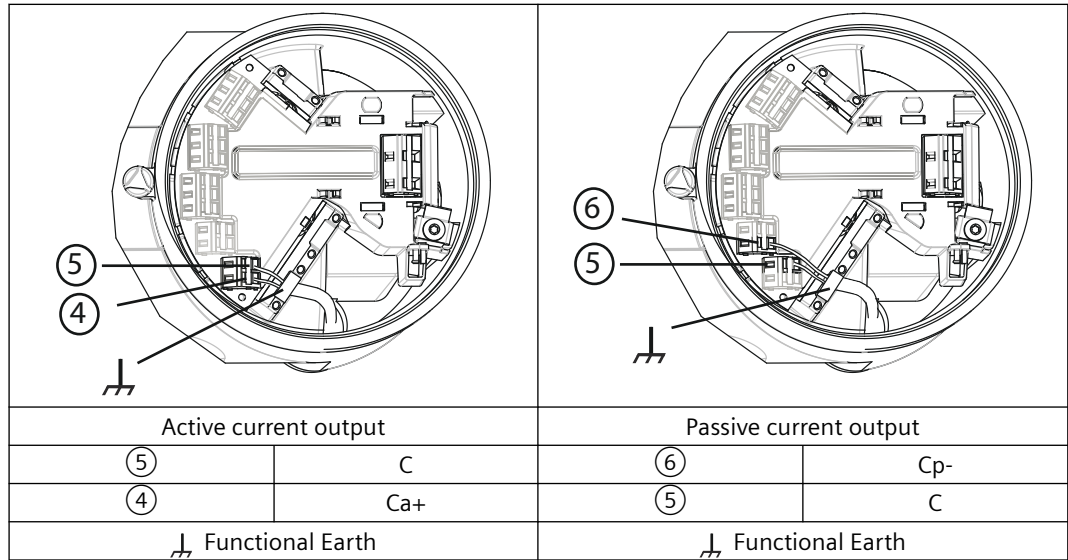

6. Tighten cable gland.

**Note**

For Ex versions active or passive current output is preselected at ordering and cannot be changed.

Non-Ex versions can be connected as either active or passive.

**Note**

**Load**

Signal output: < 500 Ω at 14 to 24 VDC (active), 14 to 30 VDC (passive)

Relay output: 30 VAC/VDC, 100 mA

Passive signal input: 15 to 30 VDC, 2 to 15 mA

### 4.6.5 Connecting channels 2 to 4

#### Connect wires

1. Remove cap and ferrule from cable gland and slide onto cable.
2. Push cable through open gland and cable path.
3. Restore ferrule and tighten cap to lightly hold cable in place.
4. Fold signal cable screen back over outer sheath and ground beneath cable clamp.  
In case of shielded cables, use metal cable glands for proper connection.
5. Connect wires to terminals using screwdriver.
6. Tighten cable gland.

The numbers in the graphics below refer to table Terminal layout (industrial enclosure) (Page 56).

#### If connected as input or output - Industrial enclosure

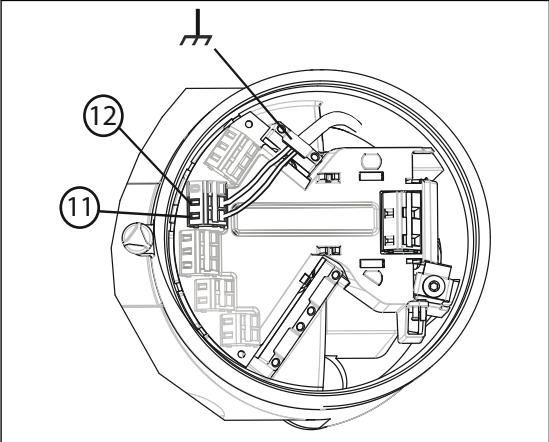
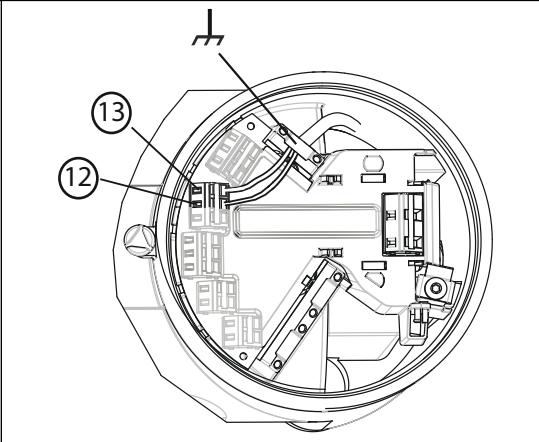
	
Active configuration	Passive configuration
⑫ IO[3] (common)	⑬ IO[3]- (passive)
⑪ IO[3]+ (active)	⑫ IO[3] (common)
⏏ Functional Earth	⏏ Functional Earth

### 4.6.6 Connecting the power supply

1. Open power supply terminal protection cover.
2. Remove cap and ferrule from cable gland and slide onto cable.

4.6 Connecting industrial enclosure

3. Push cable through open gland and cable path.

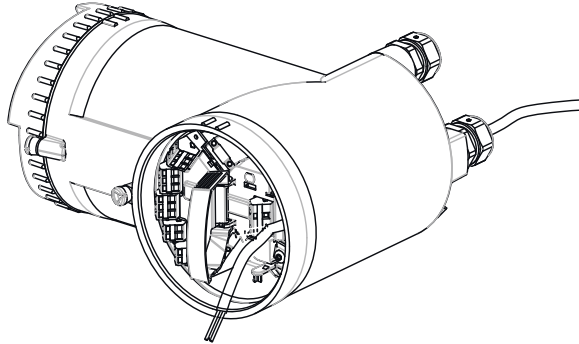

4. Restore ferrule and tighten cap to lightly hold cable in place.
5. Connect ground to terminal  $\oplus$  and power to terminals L/+ and N/- using wiring tool in the manner shown below at right.

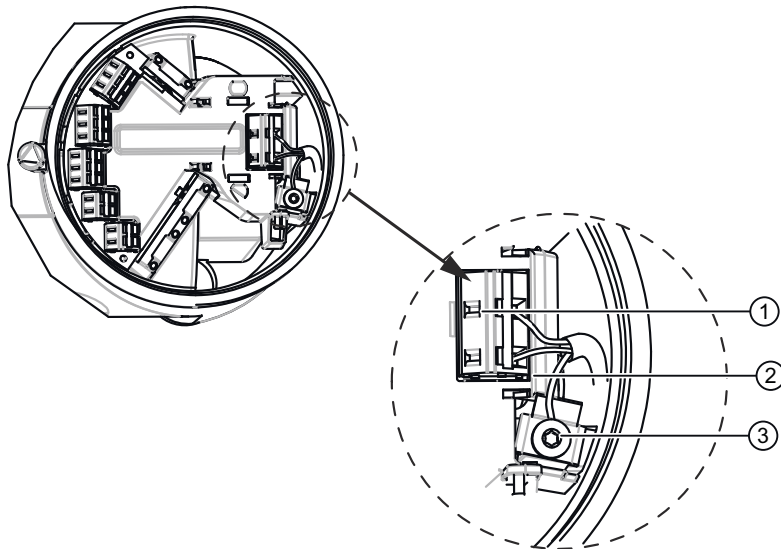

- ① L/+
- ② N/-
- ③  $\oplus$  Protective Earth (PE)

AC connection	DC connection																		
<table border="0"> <tr> <td style="border: 1px solid black; padding: 2px;">L/+</td> <td style="padding: 0 10px;">←</td> <td>L</td> </tr> <tr> <td style="border: 1px solid black; padding: 2px;">N/-</td> <td style="padding: 0 10px;">←</td> <td>N</td> </tr> <tr> <td style="border: 1px solid black; padding: 2px;"><math>\oplus</math></td> <td style="padding: 0 10px;"></td> <td><math>\oplus</math></td> </tr> </table>	L/+	←	L	N/-	←	N	$\oplus$		$\oplus$	<table border="0"> <tr> <td style="border: 1px solid black; padding: 2px;">L/+</td> <td style="padding: 0 10px;">←</td> <td>+</td> </tr> <tr> <td style="border: 1px solid black; padding: 2px;">N/-</td> <td style="padding: 0 10px;">←</td> <td>-</td> </tr> <tr> <td style="border: 1px solid black; padding: 2px;"><math>\oplus</math></td> <td style="padding: 0 10px;"></td> <td><math>\oplus</math></td> </tr> </table>	L/+	←	+	N/-	←	-	$\oplus$		$\oplus$
L/+	←	L																	
N/-	←	N																	
$\oplus$		$\oplus$																	
L/+	←	+																	
N/-	←	-																	
$\oplus$		$\oplus$																	
Power: 100 to 240 V AC, 47 to 63 Hz	Power: 20 to 27 V DC																		

6. Close and latch power supply terminal protection cover.
7. Tighten cable gland.

## 4.6.7 Finishing the transmitter connection (Industrial enclosure)

### Connection check-up

1. Check individual wire installation by tugging firmly.
2. In case of Ex, remove all plastic blind plug caps and mount Ex rated cable glands or Ex rated blind plugs in unused cable entries.  
To ensure IP rating, remove caps and mount appropriate cable glands and blind plugs in unused cable entries.  
Firmly tighten cable glands.
3. Check individual wire installation by tugging firmly.
4. Remove O-ring from lid.
5. Reinstall lid and screw in until mechanical stop. Wind back lid by one turn.
6. Mount O-ring by pulling it over the lid and tighten lid cover until you feel friction from the O-ring on both sides. Wind lid further by one quarter of a turn to seal on the O-ring.
7. Reinstall and tighten lid lock screw.
8. Ensure that moisture does not penetrate the inside of electronics enclosure. Bend cables downward immediately before cable glands.

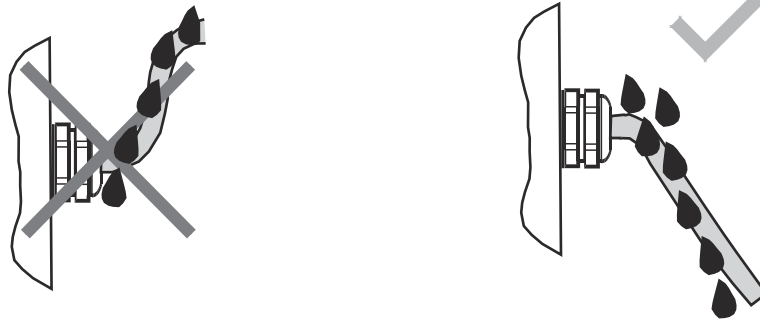

## 4.7 Connecting wall mount enclosure

### 4.7.1 Preparing wall mount enclosure connections

1. Remove blind plugs where required.

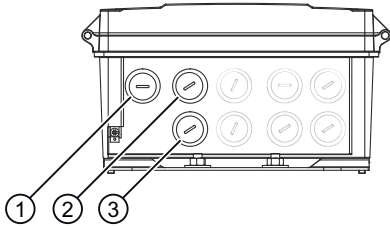

- ① Power supply connection
- ② Input/output connection (channels 2 to 4)
- ③ Modbus connection

2. Loosen spring screws on enclosure lid.
3. Open enclosure lid. A nameplate showing the configuration is placed on the inside of the transmitter enclosure lid.

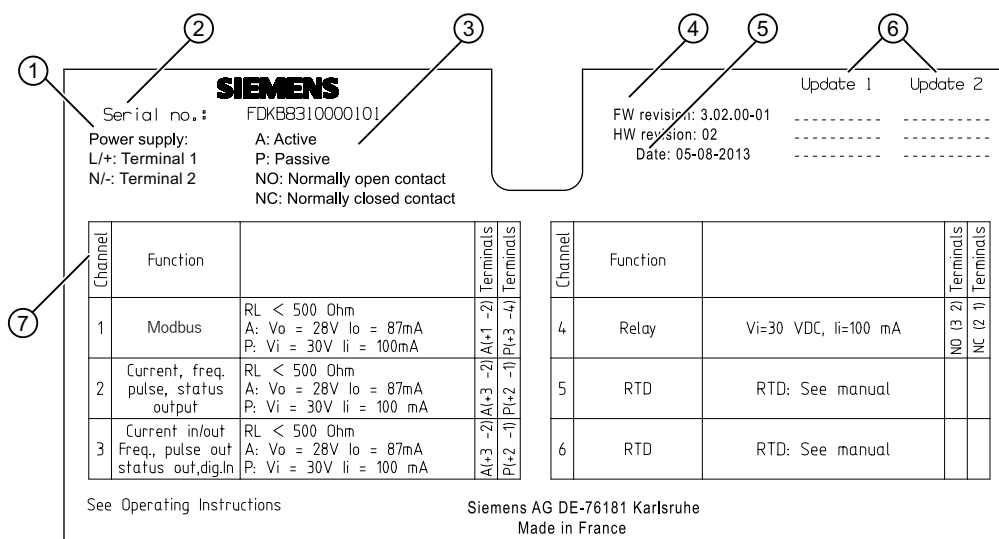

- ① Power supply connections
  - L/+ Terminal 1
  - N/- Terminal 2
  - ⊕ Terminal 3
- ② Serial no.
- ③ Key to symbols
  - A Configured as active input/output
  - P Configured as passive input/output
  - NO Connected as normally open contact
  - NC Connected as normally closed contact
- ④ Initial firmware and hardware revisions
- ⑤ Device configuration date
- ⑥ Updates (to be filled in on firmware and hardware updates)
- ⑦ Configuration of channels 1 to 6

Figure 4-10 Example configuration label

See also

Input/output configuration (Page 77)

4.7.1.1 Terminal layout (wall mount)

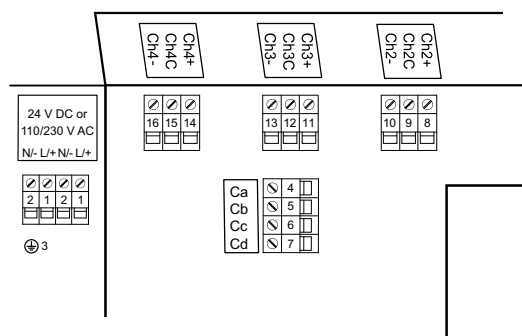

4.7 Connecting wall mount enclosure

For configuration of the software parameters, see Input/output configuration (Page 77). More information can be found in the Function Manual.

The following table shows:

- Which cable with which terminal
- Hardware and software configuration of the channels

HW configuration	SW configuration	Terminals															
		Power supply			Ch1				Ch2			Ch3			Ch4		
		1	2	3	4	5	6	7	8	9	10	11	12	13	14	15	16
Power supply		L+	N-	⊕													
Channel 1 HART	Current output HART				Active/+ In	Active/ - Passive/+ - (A)	Passive/- -										
Channel 1 MODBUS					+ (B)	- (A)		Out + (B) - (A)									
Channel 1 PROFIBUS					In + (B)	- (A)		Out + (B) - (A)									
Channel 2 output	Current, Frequency, Pulse and Status								Active/+	Active/ - Passive/+	Passive/-						
Channel 3 & 4 Input and output	Outputs: Current, Frequency, Pulse and Status Inputs: Digital											Active/+	Active/ -		Active/+	Active/ -	
Channel 3 & 4 Relay	Status output											NO	Passive/+ NC	Passive/- NC	NO	Passive/+ NC	Passive/- NC

Figure 4-11 Terminals/configuration overview

**Ex and non-Ex versions**

- For Ex versions active or passive current output is preselected at the time of ordering and cannot be changed.
- Non-Ex versions can be connected as either active or passive.

4.7.2 Connecting the sensor cables (internal DSL only)

**Preparing for the connection**

1. Loosen the four lid screws.
2. Open the lid.
3. Remove F-connector tool from wall mount enclosure.

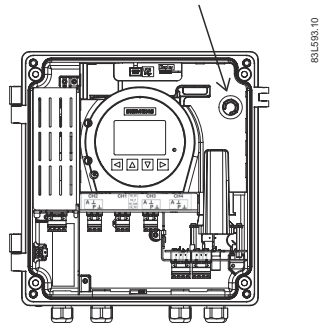
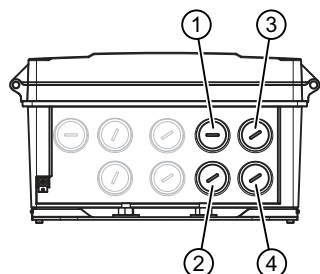

Figure 4-12 F-connector tool location



### Connecting the flow sensor cables

When connecting the sensors it is required for the system to function that the sensor cables are connected correctly. Both sensor cables for each path must be connected to the same port numbers (1A and 1B or 2A and 2B) on the transmitter.



- |   |                            |
|---|----------------------------|
| ① Path 1 - Upstream sensor cable (1A)   | ③ Path 2 - Upstream (2A)   |
| ② Path 1 - Downstream sensor cable (1B) | ④ Path 2 - Downstream (2B) |

The sensor cables are delivered with a premounted F-connector at the transmitter end.

1. Remove the blind plug from the wall mount enclosure.
2. Slide the cable gland back onto the cable and allow access for the F-connector tool.
3. Place F-connector tool around cable and slide up to engage F-connector nut.
4. Push cable through the gland opening. Ensure that the center lead is aligned with connector port in the transmitter.
5. Tighten the F-connector using the tool until you meet a mechanical stop.

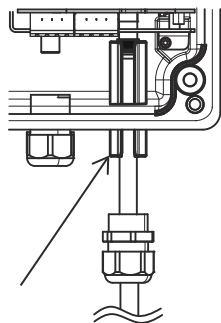

6. Remove the F-connector tool.
  7. Mount and tighten the cable gland.
- Repeat these steps for each sensor cable.

### 4.7.3 Connecting the SSL cable (wall mount enclosure)

#### M12 connector version

The SSL cable is provided with M12 style stainless steel plugs.

The cable shield is physically and electrically terminated within the body of the plug.

**Note**

Never pull the cable by the plug - only by the cable itself.

1. Connect the external DSL to the transmitter using the supplied 4-wire cable with M12 connectors.

**Note**

**Grounding**

The SSL cable shield is only mechanically connected to the grounding terminal (PE), when the M12 plug is correctly tightened.

**M20 connector version**

1. Prepare SSL cable by stripping it at both ends.

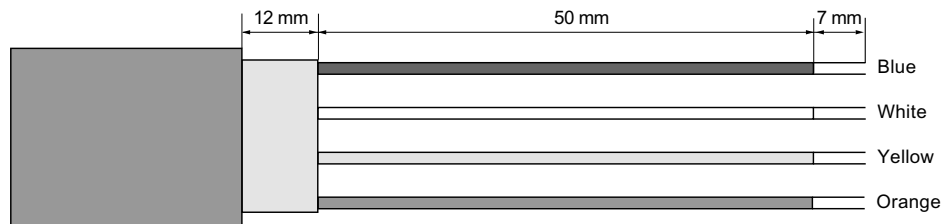

Figure 4-13 Cable end

2. Remove cap and ferrule from cable gland and slide onto cable.
3. Remove blind plug ① and fit cable gland.

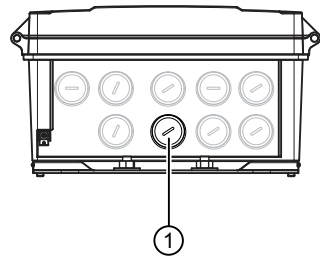

Figure 4-14 Connection - SSL cable blind plugs

4. Push cable through gland opening.

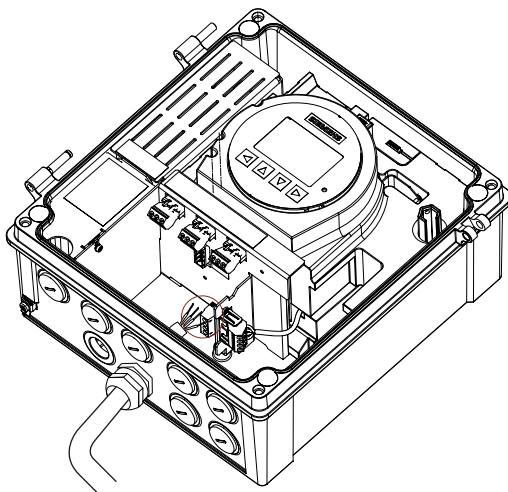
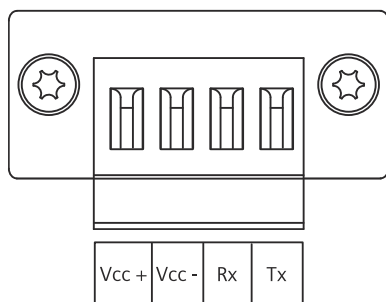

Figure 4-15 Connection - SSL cable inside

5. Connect the four wires according to list below.



Terminal number	Description	Wire color (SSL cable)
17	Vcc+	Orange
18	Vcc-	Yellow
19	Rx	White
20	Tx	Blue

6. Assemble and tighten cable gland.

#### Connecting sensor DSL

1. Remove lock screw and remove DSL lid.
2. Undo the flexible strap.
3. Disconnect sensor connection from DSL cassette.
4. Loosen mounting screw using a TX10 Torx driver and remove DSL cassette from housing.
5. Remove cap and ferrule from cable gland and slide onto cable.
6. Push cable through open gland; anchor cable screen and wires with clamp bar.
7. Remove terminal block from DSL cassette.

4.7 Connecting wall mount enclosure

8. Connect wires to terminals according to list below.

Terminal number	Description	Wire color (Siemens cable)
1	20 V	Orange
2	0 V	Yellow
3	RS-485 / B	White
4	RS-485 / A	Blue

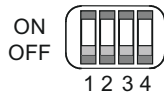
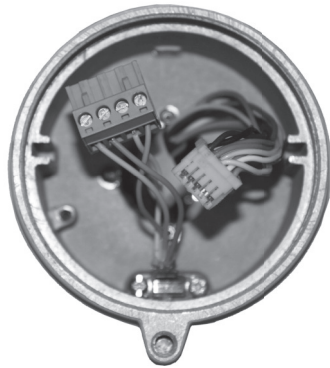

- 9. Ensure the DIP switches are all set to OFF.
- 10. Reinstall DSL cassette including mounting screw.
- 11. Connect sensor connection and sensor cable plugs.
- 12. Restore flexible strap around all wires.

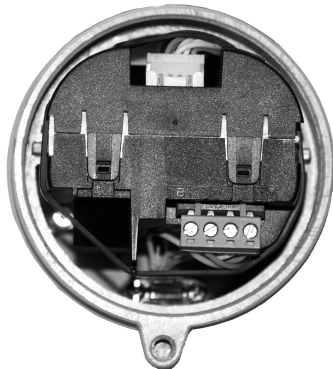

- 13. Assemble and tighten cable gland.
- 14. Remove O-ring from DSL lid.
- 15. Reinstall lid and screw in until mechanical stop. Wind back lid by one turn.
- 16. Mount O-ring by pulling it over the DSL lid and tighten lid until you feel friction from the O-ring on both sides. Wind lid further by one quarter of a turn to seal on the O-ring.
- 17. Reinstall and tighten lid lock screw.
- 18. Close and secure DSL lid including lock screw. Turn the lid until you can feel the friction of the O-ring. From this point turn the lid 1/4 turn to be tight.

#### 4.7.4 Connecting Modbus (wall mount)

##### Procedure

1. Open enclosure lid.
2. Remove blind plug and fit cable gland.
3. Push cable through open gland and cable path.

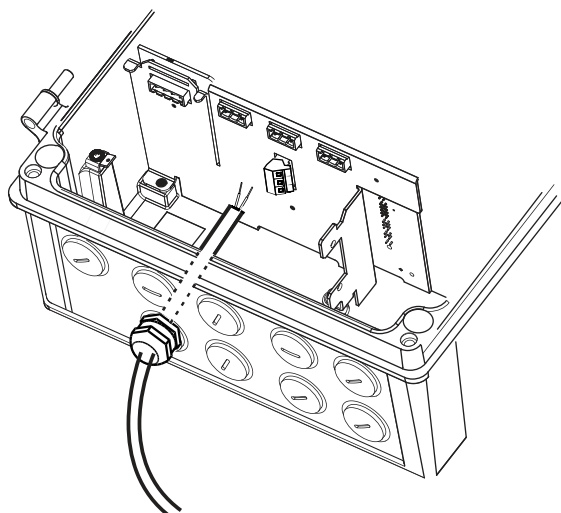

4. Restore ferrule and tighten cap to hold cable in place.
5. Connect wires to terminals using wiring tool.

##### Note

##### The terminal connector is detachable

For easier access unplug the terminal connector. After connecting the wires, plug the terminal connector back in.

##### – Wall mount transmitter

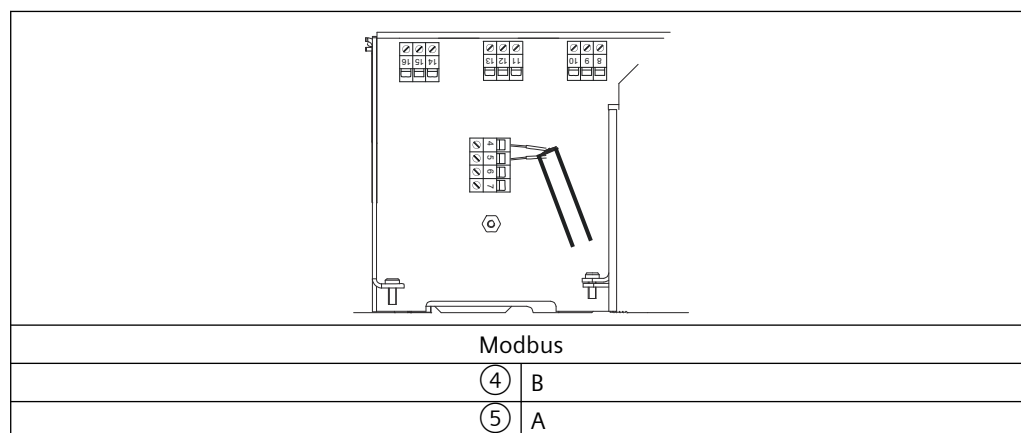

6. Tighten cable gland.

### 4.7.5 Connecting HART

---

**Note**

**4 to 20 mA output**

It is not required to use shielded cables for the pure 4 to 20 mA current output.

---

**Note**

**HART communication**

It is recommended by the FieldComm Group (FCG) to use shielded cables for the HART communication.

---

#### Procedure

1. Open enclosure lid.
2. Remove blind plug and fit cable gland.
3. Push cable through open gland and cable path.

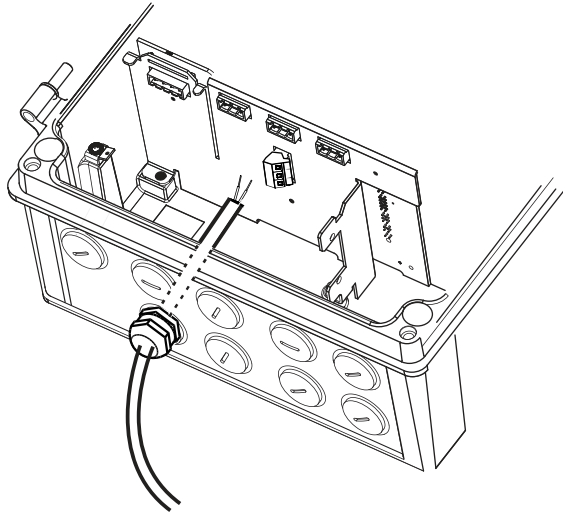

4. Restore ferrule and tighten cap to hold cable in place.

5. Connect wires to terminals using a screwdriver.

**Note**

**The terminal connector is detachable**

For easier access unplug the terminal connector. After connecting the wires, plug the terminal connector back in.

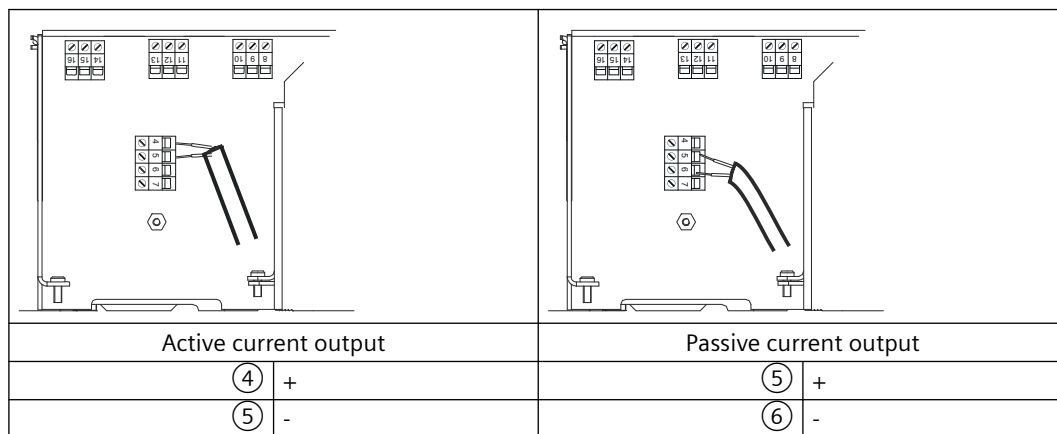

6. Termination of channel 1. The numbers refer to table Terminal layout (wall mount) (Page 67).

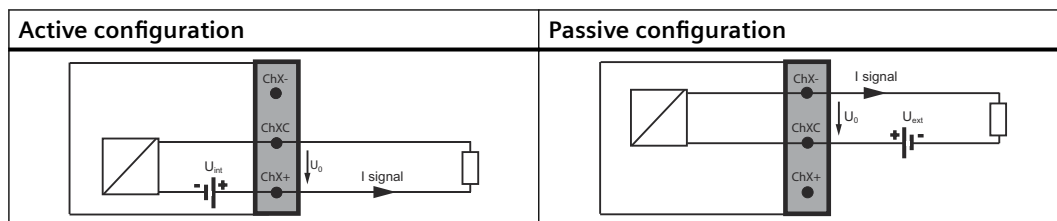

7. Tighten cable gland.

**Note**

For Ex versions active or passive current output is preselected at the time of ordering and cannot be changed.

Non-Ex versions can be connected as either active or passive.

#### 4.7.6 Connecting channels 2 to 4

Channel 2 is for output only, channels 3 to 4 can be ordered as either inputs/outputs or relays, see Preparing wall mount enclosure connections (Page 66)

**Connect wires**

**Note**

**Additional load resistor**

Depending on the internal load of an externally connected device, an additional load resistor might be required, for the pulse, status and frequency functions to work properly. See Technical specifications (Page 97) for load specifications.

1. Remove cap and ferrule from cable gland and slide onto cable.  
Wall mount enclosure: Remove blind plug and fit cable gland.
2. Push cable through open gland and cable path.
3. Restore ferrule and tighten cap to hold cable in place.  
In case of shielded cables, use metal cable glands for proper connection.
4. Connect wires to terminals using a screwdriver.

**Note**

**The terminal connector is detachable**

For easier access unplug the terminal connector. After connecting the wires, plug the terminal connector back in.

5. Tighten cable gland.

The numbers in the graphics below refer to table Preparing wall mount enclosure connections (Page 66)

**If connected as input or output (channels 2 to 4)**

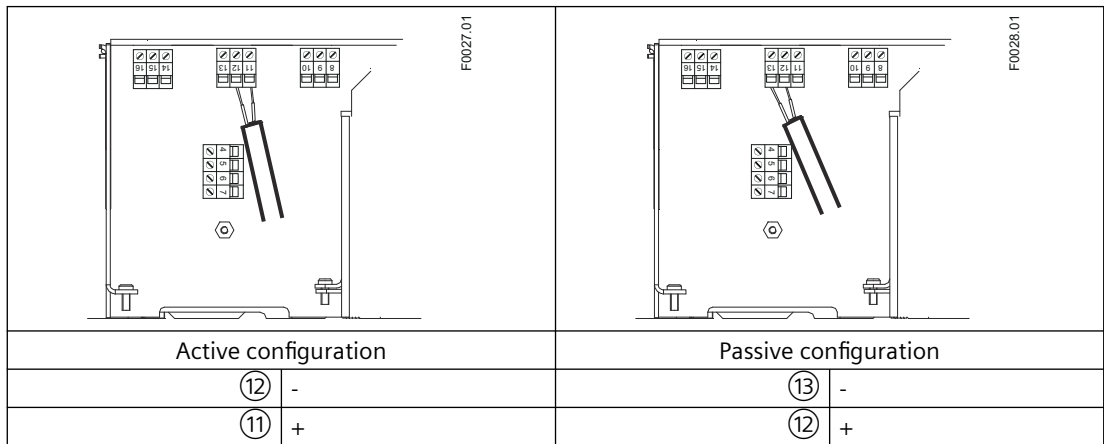

Termination example for channel 3



**If connected as relay (channels 3 and 4 only)**

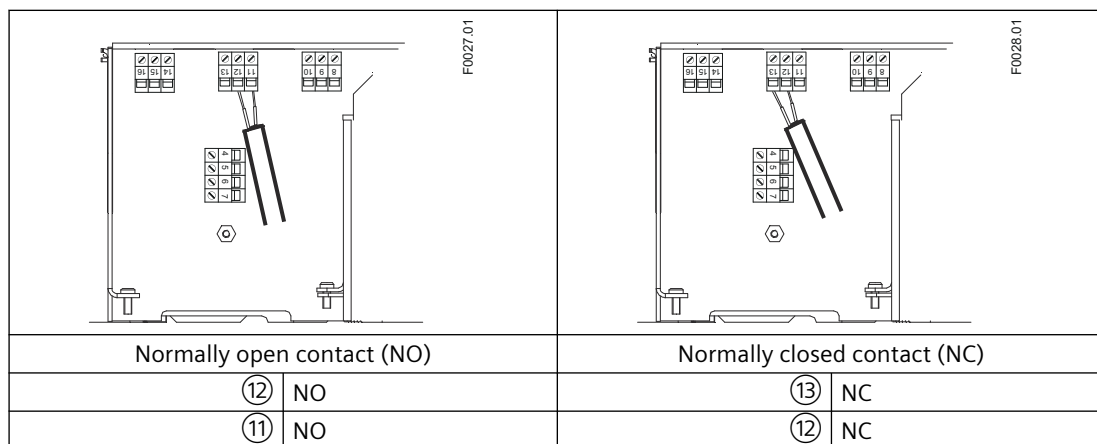

Termination example for channel 3 - relay connection

**4.7.6.1 Input/output configuration**

All pressure values are handled as absolute pressure. If connected pressure transmitters measure the pressure in gauge pressure, then please convert to gauge pressure by adjusting the upper and lower range values.

**Note**

**All pressure values are handled as absolute pressure**

If connected pressure transmitters measure the pressure in gauge pressure, then please convert to gauge pressure by adjusting the upper and lower range values.

Configuration	Software configuration	Channel			
		2	3	4	
Output Active	Current output Frequency output Pulse output Status output <ul style="list-style-type: none"> <li>Alarm class</li> <li>Alarm item</li> <li>NAMUR status signals</li> </ul>	X	X	X	<p>Active</p>
Output Passive	Current output Frequency output Pulse output Status output <ul style="list-style-type: none"> <li>Alarm class</li> <li>Alarm item</li> <li>NAMUR status signals</li> </ul>	X	X	X	<p>Passive</p>

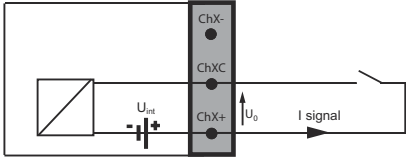
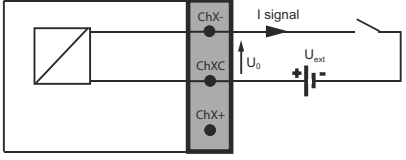
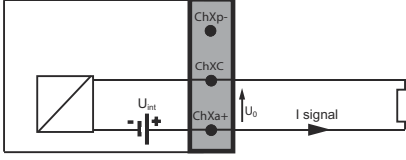
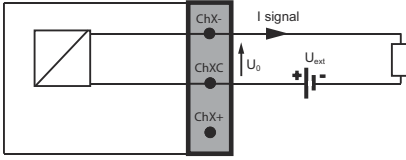
Configuration	Software configuration	Channel			
		2	3	4	
Input Active	Digital input <ul style="list-style-type: none"> <li>Reset totalizer 1</li> <li>Reset totalizer 2</li> <li>Reset totalizer 3</li> <li>Reset all totalizers</li> <li>Force outputs</li> <li>Freeze process values</li> <li>Zero adjust</li> </ul>		X	X	 <p>Active</p>
Input Passive	Digital input <ul style="list-style-type: none"> <li>Reset totalizer 1</li> <li>Reset totalizer 2</li> <li>Reset totalizer 3</li> <li>Reset all totalizers</li> <li>Force outputs</li> <li>Freeze process values</li> <li>Zero adjust</li> </ul>		X	X	 <p>Passive</p>
Current input Active	Process values <ul style="list-style-type: none"> <li>Pressure</li> <li>Medium temperature</li> <li>Viscosity</li> <li>Density</li> <li>Sensor temperature</li> <li>Auxiliary temperature</li> </ul>		X	X	 <p>Active</p>
Current input Passive	Process values <ul style="list-style-type: none"> <li>Pressure</li> <li>Medium temperature</li> <li>Viscosity</li> <li>Density</li> </ul>		X	X	 <p>Passive</p>

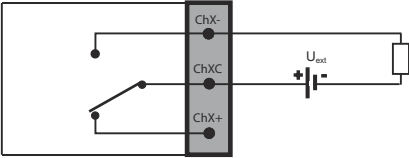
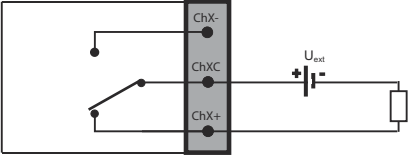
Configuration	Software configuration	Channel			
		2	3	4	
Relay output Normally open	Alarm class Alarm item NAMUR status signals		X	X	 <p>Normally open</p>
Relay output Normally closed	Alarm class Alarm item NAMUR status signals		X	X	 <p>Normally closed</p>

#### 4.7.7 Connecting channels 5 and 6 (internal DSL only)

##### Connecting RTD (Resistance Temperature Detector) cable

Perform the following steps for each RTD cable.

1. Loosen the four lid screws and open lid.
2. Remove cap and ferrule from cable gland and slide onto cable.
3. Remove one of the blind plugs (④ or ⑤) and fit cable gland.

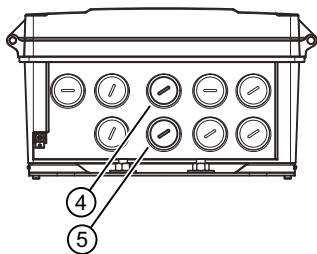

4. Push cable through gland opening.

4.7 Connecting wall mount enclosure

5. Connect the two, three or four wires to the terminal block as shown below. Short-circuit terminals as required.

---

**Note**

**The terminal connector is detachable**

For easier access unplug the terminal connector. After connecting the wires, plug the terminal connector back in.

---

**Note**

**RTD shield grounding**

Make sure that the RTD cable shield is properly grounded. Consult the FSS200 Installation Manual on how to ground the RTD cable shield.

---

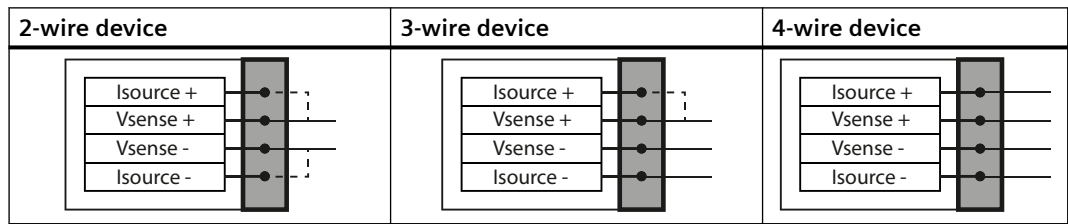

6. Assemble and tighten cable gland.

### 4.7.8 Connecting the power supply (wall mount)

---

**Note**

**Power supply wiring**

- 0.2 to 2.5 mm (24 AWG to 12 AWG) solid or stranded
  - torque between 0.5 to 0.6 Nm
  - One wire per terminal connection
- 

1. Open enclosure lid, unscrew power supply terminal protection cover screw, and remove protection cover.
2. Remove blind plug and fit cable gland.

3. Push cable through open gland and cable path

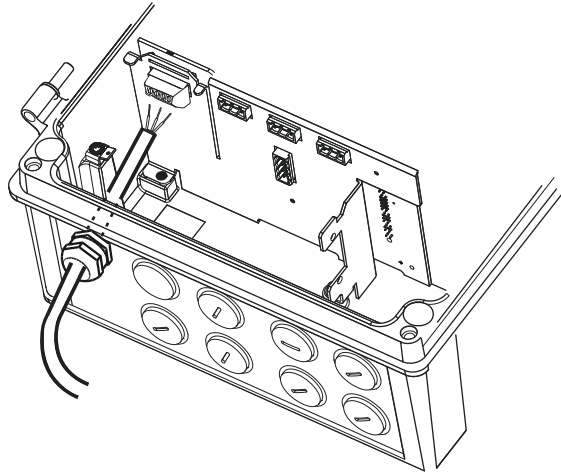

4. Restore ferrule and tighten cap to lightly hold cable in place.

4.7 Connecting wall mount enclosure

- Connect ground to terminal  $\oplus$  and power to terminals L/+ and N/- in the manner shown below at right using a screwdriver.

**Note**

**The terminal connector is detachable**

For easier access unplug the terminal connector. After connecting the wires, plug the terminal connector back in.

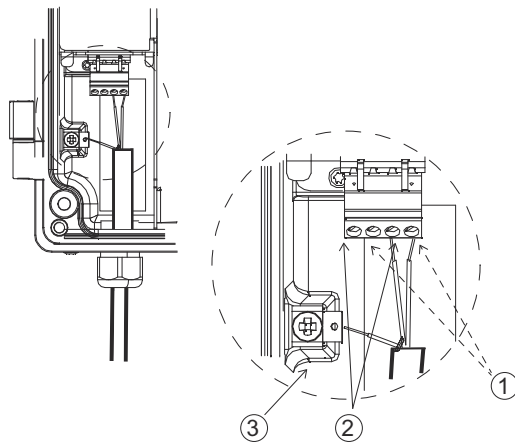

- ① L/+
- ② N/-
- ③  $\oplus$  Protective Earth (PE)

AC connection	DC connection																		
<table border="0"> <tr> <td style="border: 1px solid black; padding: 2px;">L/+</td> <td style="padding: 0 10px;">←</td> <td>L</td> </tr> <tr> <td style="border: 1px solid black; padding: 2px;">N/-</td> <td style="padding: 0 10px;">←</td> <td>N</td> </tr> <tr> <td style="border: 1px solid black; padding: 2px; text-align: center;"><math>\oplus</math></td> <td style="padding: 0 10px;"></td> <td style="text-align: center;"><math>\oplus</math></td> </tr> </table>	L/+	←	L	N/-	←	N	$\oplus$		$\oplus$	<table border="0"> <tr> <td style="border: 1px solid black; padding: 2px;">L/+</td> <td style="padding: 0 10px;">←</td> <td>+</td> </tr> <tr> <td style="border: 1px solid black; padding: 2px;">N/-</td> <td style="padding: 0 10px;">←</td> <td>-</td> </tr> <tr> <td style="border: 1px solid black; padding: 2px; text-align: center;"><math>\oplus</math></td> <td style="padding: 0 10px;"></td> <td style="text-align: center;"><math>\oplus</math></td> </tr> </table>	L/+	←	+	N/-	←	-	$\oplus$		$\oplus$
L/+	←	L																	
N/-	←	N																	
$\oplus$		$\oplus$																	
L/+	←	+																	
N/-	←	-																	
$\oplus$		$\oplus$																	
Power: 100 to 240 V AC, 47 to 63 Hz	Power: 20 to 27 V DC																		

- Tighten cable gland.
- Mount power supply protection cover and fasten protection cover screw.

### 4.7.9 Finishing the transmitter connection (wall mount)

**Connection check-up**

- Check individual wire installation by tugging firmly.
- In case of Ex, remove all plastic blind plug caps and mount Ex rated cable glands or Ex rated blind plugs in unused cable entries.  
To ensure IP rating, remove caps and mount appropriate cable glands and blind plugs in unused cable entries.  
Firmly tighten cable glands.

3. Check individual wire installation by tugging firmly.
4. Close lid.
5. Tighten the four spring screws.
6. Ensure that moisture does not penetrate to inside of electronics enclosure.





# Commissioning

## 5.1 Basic Safety Notes

### DANGER

#### Toxic gases and liquids

Danger of poisoning when venting the device: if toxic process media are measured, toxic gases and liquids can be released.

- Before venting ensure that there are no toxic gases or liquids in the device, or take the appropriate safety measures.

### WARNING

#### Commissioning and operation with error message

If an error message displays, correct operation is no longer guaranteed.

- Check the severity of the error.
- Correct the error.
- If the error still exists:
  - Take the device out of operation.
  - Do not restart the device.

The same risk continues to apply when error messages are switched off or disabled.

### WARNING

#### Improper commissioning in hazardous areas

Device failure or risk of explosion in hazardous areas.

- Do not commission the device until it has been mounted completely and connected in accordance with the information in Technical specifications (Page 97).
- Before commissioning take the effect on other devices in the system into account.

 <b>WARNING</b>
<b>Opening device in energized state</b>
Risk of explosion in hazardous areas
<ul style="list-style-type: none"><li>• Only open the device in a de-energized state.</li><li>• Check prior to commissioning that the cover, cover locks, and cable inlets are assembled in accordance with the directives.</li></ul>
<b>Exception:</b> Devices having the type of protection "Intrinsic safety Ex i" may also be opened in energized state in hazardous areas.

 <b>WARNING</b>
<b>Hazardous contact voltage</b>
Risk of injury through hazardous contact voltage when the device is open or not completely closed.
The degree of protection specified on the nameplate or in Technical specifications (Page 97) is no longer guaranteed if the device is open or not properly closed.
<ul style="list-style-type: none"><li>• Make sure that the device is securely closed.</li></ul>

 <b>WARNING</b>
<b>Risk of explosion when media above 100 °C flows through the process flange</b>
Explosion protection is no longer guaranteed and the approval is nullified.
It is prohibited for media above 100 °C to continually flow through the process flange.

 <b>WARNING</b>
<b>Loss of explosion protection</b>
Risk of explosion in hazardous areas if the device is open or not properly closed.
<ul style="list-style-type: none"><li>• Close the device as described in Connecting (Page 35).</li></ul>

 <b>WARNING</b>
<b>Hot surfaces</b>
Risk of burns resulting from hot surfaces.
<ul style="list-style-type: none"><li>• Take corresponding protective measures, for example by wearing protective gloves.</li></ul>

**Note****Verify proper operation and configuration of all analog inputs**

Incorrect configuration can have a negative impact on flow compensation and produce errors in flow rate.

## 5.2 Local display

The device is commissioned/operated with the buttons on the local display.

The buttons are actuated by touching the glass panel on the appropriate button. The graphical display above the buttons gives a menu-guided operation of the individual device function/parameters. Successful operation of the button is confirmed by a small green LED next to the display.

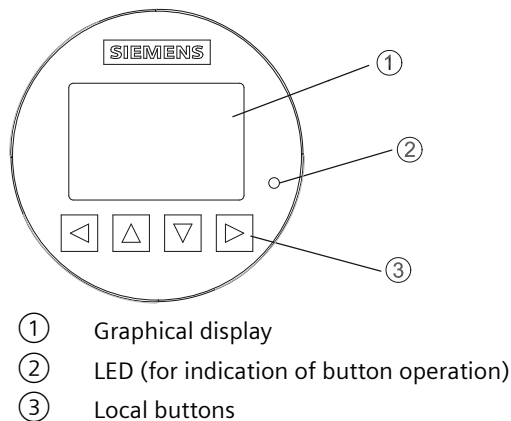
**Note****Calibration of the buttons**

When the lid is closed, all buttons are calibrated. During calibration the LED is on and the buttons cannot be operated.

If one of the buttons is pressed for more than 10 seconds, the calibration of this button begins which has a duration of less than 10 seconds. Release the button for further operation.

**Note****Local display timeout**

If no button is pressed for 10 minutes, the display switches to show operation view. If Backlight is set to Automatic, display backlight goes off automatically 30 seconds after the last button press.

---

**Note**

Operation does not require opening of the device. This means that the high degree of protection of IP67 and safety in hazardous areas are guaranteed at all times.

---

### 5.3 Access control

You can view all items in the HMI menu but the parameters are protected against changes through access level control. To gain access, select one of the following access levels:

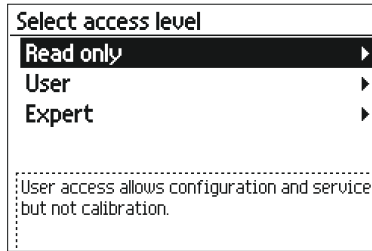

- Read only  
Allows no configuration. The user is only able to view the parameter values. No PIN code required.
- User  
Allows configuration and service of all parameters except calibration parameters. Default PIN code is 2457.
- Expert  
Allows configuration and service of all parameters including flow and density calibration parameters. Default PIN code is 2834.

PIN codes can be changed in **Security** (5).

---

**Note**

**Lost PIN code**

If the PIN code is lost, provide Siemens customer support with the transmitter serial number (see nameplate). Siemens customer support will provide a code to be entered in **PIN recovery** (5.4).

---

#### Disable access level control

If logged in as Expert you can **Deactivate user PIN** meaning that you will always be logged in as User and will not be prompted to enter the password. Enabling the access level control can be done in **Activate user PIN** and requires entering the Expert password.

## Auto logout function

You will **not** be prompted for password for 10 minutes after the last key press.

<b>NOTICE</b>
<b>Device restart</b>
Whenever the device is restarted, the access level is reset to Read only.

## 5.4 Device startup

### Condition

You have read the Basic Safety Notes (Page 85).

### Procedure

1. Power-on the device.  
For an initial startup, prompts for each of the following steps appear after power-on.
2. Set the language.  
The first time the device is configured, you will be prompted to set the language. The parameter "Language" always appears in English. To change the language after initial setup, access menu item 6.
3. Set the date and time.  
The correct date and time should be set prior to configuring the device.
4. Run the "Quick commissioning wizard".  
Essential parameters should be considered before using the device for the first time.
  - Choose "Yes" (recommended) to start the "Quick commissioning" wizard.
  - Choose "No", you accept the default values of the device (no sensors are configured).  
The next HMI view will be the operation view 1.

For any subsequent startup, after power-on, the device automatically starts in operation view. A transition screen showing first the Siemens logo and then the current firmware revision of the product is displayed while the first measurement is being processed.

### See also

FST030 HMI export in SIOS (<https://support.industry.siemens.com/cs/document/109793928>)





## Service and maintenance

### 6.1 Basic safety notes

 <b>WARNING</b>
<b>Dust layers above 5 mm</b> Risk of explosion in hazardous areas. Device may overheat due to dust build up. <ul style="list-style-type: none"><li>• Remove dust layers in excess of 5 mm.</li></ul>

<b>NOTICE</b>
<b>Penetration of moisture into the device</b> Damage to device. <ul style="list-style-type: none"><li>• Make sure when carrying out cleaning and maintenance work that no moisture penetrates the inside of the device.</li></ul>

 <b>CAUTION</b>
<b>Releasing button lock</b> Improper modification of parameters could influence process safety. <ul style="list-style-type: none"><li>• Make sure that only authorized personnel may cancel the button locking of devices for safety-related applications.</li></ul>

 <b>WARNING</b>
<b>Use of a computer in a hazardous area</b> If the interface to the computer is used in the hazardous area, there is a risk of explosion. <ul style="list-style-type: none"><li>• Ensure that the atmosphere is explosion-free (hot work permit).</li></ul>

## 6.2 Cleaning

### Cleaning the enclosure

- Clean the outside of the enclosure with the inscriptions and the display window using a cloth moistened with water or a mild detergent.
- Do not use any aggressive cleansing agents or solvents, e.g. acetone. Plastic parts or the painted surface could be damaged. The inscriptions could become unreadable.

 **WARNING**

**Electrostatic charge**

Risk of explosion in hazardous areas if electrostatic charges develop, for example, when cleaning plastic surfaces with a dry cloth.

- Prevent electrostatic charging in hazardous areas.

## 6.3 Maintenance and repair work

 **WARNING**

**Impermissible repair of explosion protected devices**

Risk of explosion in hazardous areas

- Repair must be carried out by Siemens authorized personnel only.

 **WARNING**

**Maintenance during continued operation in a hazardous area**

There is a risk of explosion when carrying out repairs and maintenance on the device in a hazardous area.

- Isolate the device from power.

- or -

- Ensure that the atmosphere is explosion-free (hot work permit).

 **WARNING**

**Impermissible accessories and spare parts**

Risk of explosion in areas subject to explosion hazard.

- Only use original accessories or original spare parts.
- Observe all relevant installation and safety instructions described in the instructions for the device or enclosed with the accessory or spare part.



 **WARNING****Humid environment**

Risk of electric shock.

- Avoid working on the device when it is energized.
- If working on an energized device is necessary, ensure that the environment is dry.
- Make sure when carrying out cleaning and maintenance work that no moisture penetrates the inside of the device.

 **CAUTION****Hot surfaces**

Risk of burns during maintenance work on parts having surface temperatures exceeding 70 °C (158 °F).

- Take corresponding protective measures, for example, by wearing protective gloves.
- After carrying out maintenance, remount touch protection measures.

 **WARNING****Enclosure open**

Risk of explosion in hazardous areas as a result of hot components and/or charged capacitors inside the device.

To open the device in a hazardous area:

1. Isolate the device from power.
2. Observe the wait time specified in Technical specifications (Page 97) or on the warning sign before opening the device.
3. Visually inspect sensor inlet and outlet.

**Exception:** Devices exclusively having Intrinsic safety (Ex i) may be opened in an energized state in hazardous areas.

 **CAUTION****Hazardous voltage at open device**

Risk of electric shock when the enclosure is opened or enclosure parts are removed.

- Before you open the enclosure or remove enclosure parts, de-energize the device.
- If maintenance measures in an energized state are necessary, observe the particular precautionary measures. Have maintenance work carried out by qualified personnel.

 <b>WARNING</b>
<b>Improper connection after maintenance</b>
Risk of explosion in areas subject to explosion hazard.
<ul style="list-style-type: none"><li>• Connect the device correctly after maintenance.</li><li>• Close the device after maintenance work.</li></ul>
Refer to Connecting (Page 35).

The device is maintenance-free. However, a periodic inspection according to pertinent directives and regulations must be carried out.

An inspection can include:

- Ambient conditions
- Seal integrity of the process connections, cable entries, and cover
- Reliability of power supply, lightning protection, and grounds

### 6.3.1 On-board battery replacement

---

**Note**

The on-board battery is used to maintain real time clock and should only be replaced with Panasonic BR1225A/BN.  
Siemens spare part number: A5E41372210

---

The battery is located in the transmitter cassette. The transmitter cassette location can be found in the exploded view.

## 6.4 Return procedure

To return a product to Siemens, see AUTOHOTSPOT.

Contact your Siemens representative to clarify if a product is repairable, and how to return it. They can also help with quick repair processing, a repair cost estimate, or a repair report/ cause of failure report.

<b>NOTICE</b>
<b>Decontamination</b>
The product may have to be decontaminated before it is returned. Your Siemens contact person will let you know for which products this is required.

**See also**

Return goods delivery note (<https://www.siemens.com/processinstrumentation/returngoodsnote>)

Decontamination declaration (<https://www.siemens.com/sc/declarationofdecontamination>)

**6.5 Disposal**

Devices described in this manual should be recycled. They may not be disposed of in the municipal waste disposal services according to the Directive 2012/19/EC on waste electronic and electrical equipment (WEEE).

Devices can be returned to the supplier within the EC and UK, or to a locally approved disposal service for eco-friendly recycling. Observe the specific regulations valid in your country.

Further information about devices containing batteries can be found at: Information about battery / product return (WEEE) (<https://support.industry.siemens.com/cs/document/109479891/>)



# Technical specifications

---

## Note

### Device specifications

Siemens makes every attempt to ensure the accuracy of these specifications but reserves the right to change them at any time.

---

## 7.1 Power

Table 7-1 Power supply

Description	Specification
Supply voltage	<ul style="list-style-type: none"> <li>100 to 240 V AC, 47 to 63 Hz</li> <li>20 to 27 V DC</li> </ul>
Power consumption	<ul style="list-style-type: none"> <li>11 W / 22 VA</li> </ul>
Environmental conditions:	<ul style="list-style-type: none"> <li>Transient over voltages up to the levels of overvoltage category II</li> <li>Temporary over voltages occurring on mains supply only</li> <li>MAINS supply voltage fluctuations up to <math>\pm 10\%</math> of the nominal voltage.</li> <li>Altitude up to 2000 m</li> </ul>
Reverse polarity protection (y / n)	Y
Galvanic isolation	2500 V AC

## 7.2 HART interface

Table 7-2 HART communication

Description	Specification
HART revision	7.5

## 7.3 Modbus interface

Table 7-3 Modbus communication

Description	Specification
Protocol version	Modbus RTU
Default transmission rate	19200 bit/s
Default parity	Even
Default device address	1

## 7.4 Inputs

Table 7-4 Digital input (Channels 3 and 4)

Description	Channels 3 and 4
Load	15 ... 30 V DC, $R_{in}$ 7 k $\Omega$
Functionality	<ul style="list-style-type: none"> <li>Reset totalizer 1, 2 or 3</li> <li>Reset all totalizers</li> <li>Freeze process values</li> <li>Force outputs</li> </ul>

Table 7-5 Current input (Channels 3 and 4)

Description	Channels 3 and 4
Signal range	<ul style="list-style-type: none"> <li>0 ... 20 mA (EX-version)</li> <li>0 ... 25 mA (non-EX-version)</li> </ul>
Resolution	0.5 $\mu$ A
Load	<ul style="list-style-type: none"> <li>&lt;470 <math>\Omega</math> (EX-version)</li> <li>&lt;770 <math>\Omega</math> (non-EX-version)</li> </ul>
Terminal voltage	<ul style="list-style-type: none"> <li>8.5 ... 30 V DC (EX-version)</li> <li>11 ... 30 V DC (non-EX-version)</li> </ul>
Voltage range	Max. 24 V DC (active) 14 ... 30 V DC (passive)
Time constant (adjustable)	0 ... 100 s
Fault current	US: <span style="float: right;">NAMUR:</span>
Measurement range	4 ... 20.8 mA <span style="float: right;">3.8 ... 20.5 mA</span>
Minimum alarm	3.75 mA <span style="float: right;">3.5 mA</span>
Maximum alarm	22.6 mA <span style="float: right;">22.6 mA</span>

Description	Channels 3 and 4
Customized fail-safe mode	<ul style="list-style-type: none"> <li>Last valid value</li> <li>Lower fault current</li> <li>Upper fault current</li> <li>Fail-safe value</li> <li>Current value</li> </ul>
Galvanic isolation	<ul style="list-style-type: none"> <li>All inputs and outputs are galvanically isolated PELV circuits with 60 V DC isolation from each other and ground. Maximum test voltage: 500 V AC</li> </ul>
Cable <sup>1)</sup>	<ul style="list-style-type: none"> <li>Standard industrial signal cable with up to 3 twisted pairs with overall screen can be connected between the transmitter and the control system. Individual pair or overall screen is optional depending on user requirements.</li> </ul>

<sup>1)</sup> User supplied cables must be suitable for 5 °C above surrounding ambient temperature.

Table 7-6 Channels 5 and 6 input (PT100, 500, 1000; current input)

Description	Channels 5 and 6
Temperature range	-50 ... 250 °C (-58 ... 482 °F)
Resolution	<0.1 mK
Accuracy	+/- 0.25 K (calibrated 4 wire)
Input protection	25 V DC overvoltage
Galvanic isolation	<ul style="list-style-type: none"> <li>All inputs are galvanically isolated PELV circuits with 60 V DC isolation from each other and ground. Maximum test voltage: 500 V AC</li> </ul>
Cabling <sup>1)</sup>	2, 3 or 4 wire

<sup>1)</sup> User supplied cables must be suitable for 5 °C above surrounding ambient temperature.

## 7.5 Outputs

Table 7-7 Current output (Channel 1)

Description	Channel 1	
Signal range	4 to 20 mA	
Resolution	0.4 µA	
Load	<ul style="list-style-type: none"> <li>Ex i: &lt;470 Ω (HART ≥ 230 Ω)</li> <li>Non-Ex: &lt;770 Ω (HART ≥ 230 Ω)</li> </ul>	
Time constant (adjustable)	0.0 to 100 s	
Fault current	4 - 20 NAMUR	4 - 20 US
Measurement range (mA)	3.8 - 20.5	4.0 - 20.8
Lower fault current (mA)	3.5	3.75
Upper fault current (mA)	22.6	22.6

Technical specifications

7.5 Outputs

Description	Channel 1
Customized fail-safe mode	<ul style="list-style-type: none"> <li>• Last valid value</li> <li>• Lower fault current</li> <li>• Upper fault current</li> <li>• Fail-safe value</li> <li>• Current value</li> </ul>
Galvanic isolation	All inputs and outputs are galvanically isolated PELV circuits with 60 V DC isolation from each other and ground. Maximum test voltage: 500 V AC
Cable <sup>1)</sup>	Standard industrial signal cable with up to 3 twisted pairs with overall screen can be connected between the transmitter and the control system. Individual pair or overall screen is optional depending on user requirements.
Voltage range	Max. 24 V DC (active) 14 to 30 V DC (passive)

<sup>1)</sup> User supplied cables must be suitable for 5°C above surrounding ambient temperature.

Table 7-8 Current output (Channels 2 to 4)

Description	Channels 2 to 4					
Signal range	0/4 to 20 mA					
Resolution	0.4 µA					
Load	<ul style="list-style-type: none"> <li>• Ex i: &lt;470 Ω</li> <li>• Non-Ex: &lt;770 Ω</li> </ul>					
Time constant (adjustable)	0.0 to 100 s					
Fault current	4-20 NAMUR	4-20 US	4-20 NAMUR	4-20 US	0-20 NAMUR	0-20 US
Measurement range (mA)	3.8 - 20.5	4.0 - 20.8	4.0 - 20.5	4.0 - 24.0	0.0 - 20.5	0.0 - 24.0
Lower fault current (mA)	3.5	3.75	2.0	2.0	0.0	0.0
Upper fault current (mA)	22.6	22.6	22.0	25.0	22.0	25.0
Customized fail-safe mode	<ul style="list-style-type: none"> <li>• Last valid value                             <ul style="list-style-type: none"> <li>– Lower fault current</li> <li>– Upper fault current</li> </ul> </li> <li>• Fail-safe value</li> <li>• Current value</li> </ul>					
Galvanic isolation	All inputs and outputs are galvanically isolated PELV circuits with 60 V DC isolation from each other and ground. Maximum test voltage: 500 V AC					
Cable <sup>1)</sup>	Standard industrial signal cable with up to 3 twisted pairs with overall screen can be connected between the transmitter and the control system. Individual pair or overall screen is optional depending on user requirements.					
Voltage range	Max. 24 V DC (active) 14 to 30 V DC (passive)					

<sup>1)</sup> User supplied cables must be suitable for 5°C above surrounding ambient temperature.



Table 7-9 Digital output

Description	Channels 2 to 4
Pulse	41.6 $\mu$ s to 5 s pulse duration
Resolution	1 $\mu$ s
Frequency	0 to 10 kHz, 50 % duty cycle, 120 % overscale provision
Resolution	0.2 Hz
Load	< 750 $\Omega$
Time constant (adjustable)	0 to 100 s
Active	0 to 24 V DC, 87 mA, short-circuit-protected
Passive	3 to 30 V DC, 100 mA, short-circuit-protected
Functions	<ul style="list-style-type: none"> <li>• Pulse</li> <li>• Frequency</li> <li>• Alarm class / NAMUR status</li> <li>• Alarm item</li> </ul>

Table 7-10 Relay output

Description	Channels 3 to 4
Type	Change-over voltage-free relay contact
Load	30 V DC (30 V AC peak), 100 mA
Functions	<ul style="list-style-type: none"> <li>• Alarm class / NAMUR status</li> <li>• Alarm item</li> </ul>

## 7.6 Energy limitation parameters FST030

Table 7-11 Output parameters - wallmount enclosure

	External DSL connections	Sensor connections	RTD connections
$U_o$	17.42 V DC	17.43 V DC	4.52 V DC
$I_o$	459 mA	452 mA	13.8 mA
$P_o$	2000 mW	991 mW	26.6 mW
$C_o$			
• Group IIC	• 338 nF	• 169.5 nF	• 4.28 $\mu$ F
• Groups IIB, III	• 1969 nF	• 985 nF	• 139 $\mu$ F
• Group IIA	• 8199 nF	• 1000 nF	• 994 $\mu$ F

7.6 Energy limitation parameters FST030

	External DSL connections	Sensor connections	RTD connections
$L_o$			
• Group IIC	• 134 $\mu$ H	• 67 $\mu$ H	• 1.87 mH
• Groups IIB, III	• 675 $\mu$ H	• 348 $\mu$ H	• 7.47 mH
• Group IIA	• 1.35 $\mu$ H	• 697 $\mu$ H	• 14.9 mH
$L_o/R_o$			
• Group IIC	• 17.8 $\mu$ H/ $\Omega$	• 18.0 $\mu$ H/ $\Omega$	• NA
• Groups IIB, III	• 71.2 $\mu$ H/ $\Omega$	• 72.2 $\mu$ H/ $\Omega$	• NA
• Group IIA	• 142 $\mu$ H/ $\Omega$	• 144 $\mu$ H/ $\Omega$	• NA

Table 7-12 I/O connections active - wallmount enclosure

	HART active	Modbus	I/O 2 active	I/O 3 active	I/O 4 active
Terminals	4, 5	4, 5, 6, 7	8, 9	11, 12	14, 15
$U_o$	28 V DC	4.2 V DC	28 V DC	28 V DC	28 V DC
$I_o$	85 mA	118 mA	87 mA	87 mA	87 mA
$P_o$	584.5 mW	124 mW	601 mW	601 mW	601 mW
$C_o$					
• Group IIC	• 72 nF	• 4200 nF	• 78 nF	• 78 nF	• 78 nF
• Groups IIB, III	• 639 nF	• 10000 nF	• 645 nF	• 645 nF	• 645 nF
• Group IIA	• 2139 nF	• 10000 nF	• 2145 nF	• 2145 nF	• 2145 nF
$L_o$					
• Group IIC	• 1.64 mH	• 2.56 mH	• 1.46 mH	• 1.46 mH	• 1.46 mH
• Groups IIB, III	• 16.4 mH	• 10.2 mH	• 15.7 mH	• 15.7 mH	• 15.7 mH
• Group IIA	• 36.0 mH	• 20.5 mH	• 34.7 mH	• 34.7 mH	• 34.7 mH

Table 7-13 Output parameters - industrial enclosure

External DSL connections	
$U_o$	17.42 V DC
$I_o$	459 mA
$P_o$	2000 mW
$C_o$	
• Group IIC	• 338 nF
• Groups IIB, III	• 1969 nF
$L_o$	
• Group IIC	• 134 $\mu$ H
• Groups IIB, III	• 675 $\mu$ H
$L_o/R_o$	
• Group IIC	• 17.8 $\mu$ H/ $\Omega$

Table 7-14 I/O connections active - industrial enclosure

	HART active	Modbus	I/O 2 active	I/O 3 active	I/O 4 active
<b>Terminals</b>	<b>4, 5</b>	<b>4, 5, 6, 7</b>	<b>8, 9</b>	<b>11, 12</b>	<b>14, 15</b>
$U_o$	28 V DC	4.2 V DC	28 V DC	28 V DC	28 V DC
$I_o$	85 mA	118 mA	87 mA	87 mA	87 mA
$P_o$	584.5 mW	124 mW	601 mW	601 mW	601 mW
$C_o$					
• Group IIC	• 72 nF	• 4200 nF	• 78 nF	• 78 nF	• 78 nF
• Groups IIB, III	• 639 nF	• 1000 $\mu$ F	• 645 nF	• 645 nF	• 645 nF
$L_o$					
• Group IIC	• 1.64 mH	• 2.51 mH	• 1.46 mH	• 1.46 mH	• 1.46 mH
• Groups IIB, III	• 16.4 mH	• 10.2 mH	• 15.7 mH	• 15.7 mH	• 15.7 mH

Table 7-15 I/O connections passive

	HART pas- sive	I/O 2 pas- sive	I/O 3 pas- sive	I/O 3 relay	I/O 4 pas- sive	I/O 4 relay
<b>Terminals</b>	<b>5, 6</b>	<b>9, 10</b>	<b>12, 13</b>	<b>11, 12, 13</b>	<b>15, 16</b>	<b>14, 15, 16</b>
$U_i$	30 V DC	30 V DC	30 V DC	30 V DC	30 V DC	30 V DC
$I_i$	100 mA	100 mA	100 mA	100 mA	100 mA	100 mA
$P_i$	1000 mW	1000 mW	1000 mW	1000 mW	1000 mW	1000 mW
$C_i$	15.8 nF	7.3 nF	7.3 nF	7.3 nF	7.3 nF	7.3 nF
$L_i$	36 $\mu$ H	36 $\mu$ H	36 $\mu$ H	36 $\mu$ H	36 $\mu$ H	36 $\mu$ H

Table 7-16 PROFIBUS - industrial enclosure

	Application with linear	Application according to FISCO (IIB)
PROFIBUS Terminal (4) and (5)	$U_i = 30$ V	$U_i = 17.5$ V
	$I_i = 380$ mA	$I_i = 380$ mA
		$P_i = 5.32$ W
	$C_i = 258$ pF	$C_i = 258$ pF
	$L_i = 2.3$ $\mu$ H	$L_i = 2.3$ $\mu$ H

**Note**

**External capacitance and inductance**

The  $C_o$  and  $L_o$  values already take into consideration the combined effects of external capacitance and inductance. No further reduction of external capacitance and inductance is required.

## 7.7 Energy limitation parameters for external DSL

Table 7-17 Input parameters

	SSL (power & signal)	Analog input I/O 5 Analog input I/O 6
$U_i$	17.42 V DC	30 V DC
$I_i$	459 mA	100 mA
$P_i$	2.0 W	0.75 W
$C_i$	2.52 nF	0 nF
$L_i$	315 nH	105 nH

Table 7-18 Siemens SSL cable capacity

SSL cables	
$C_i$	264.6 pF/m
$L_i$	1.12 $\mu$ H/m

Table 7-19 Output parameters

	RTD 5, RTD 6 (any combination of connections)	Sensor outputs, each (up to 8)
$U_o$	4.52 V DC	17.43 V DC
$I_o$	13.8 mA	452 mA
$P_o$	26.6 mW	991 mW
$C_o$	<ul style="list-style-type: none"> <li>• Group IIC • 4.28 <math>\mu</math>F</li> <li>• Groups IIB, III • 139.5 <math>\mu</math>F</li> <li>• Group IIA • 994 <math>\mu</math>F</li> </ul>	<ul style="list-style-type: none"> <li>• 169.5 nF</li> <li>• 985 nF</li> <li>• 1000 nF</li> </ul>
$L_o$	<ul style="list-style-type: none"> <li>• Group IIC • 1.87 mH</li> <li>• Groups IIB, III • 7.47 mH</li> <li>• Group IIA • 14.9 mH</li> </ul>	<ul style="list-style-type: none"> <li>• 67 <math>\mu</math>H</li> <li>• 348 <math>\mu</math>H</li> <li>• 697 <math>\mu</math>H</li> </ul>
$L_o/R_o$	<ul style="list-style-type: none"> <li>• Group IIC • NA</li> <li>• Groups IIB, III • NA</li> <li>• Group IIA • NA</li> </ul>	<ul style="list-style-type: none"> <li>• 18.0 <math>\mu</math>H/<math>\Omega</math></li> <li>• 72.2 <math>\mu</math>H/<math>\Omega</math></li> <li>• 144 <math>\mu</math>H/<math>\Omega</math></li> </ul>

**Note**

**External capacitance and inductance**

The  $C_o$  and  $L_o$  values already take into consideration the combined effects of external capacitance and inductance. No further reduction of external capacitance and inductance is required.

## 7.8 Construction

Table 7-20 Designated use

Description	Specification
Measurement of process medium	<ul style="list-style-type: none"> <li>Fluid Group 1 (suitable for dangerous fluids)</li> <li>Aggregate state: Paste/light slurry, liquid and gas</li> </ul>

Table 7-21 System design

Description	Specification
Measuring principle	Ultrasonic
System architecture	Wall mount enclosure with internal DSL Wall mount enclosure with external DSL Industrial enclosure with external DSL

### Transmitter design

Table 7-22 Industrial enclosure transmitter design

Description	Specification
Dimension and weight	See Industrial enclosure dimensions (Page 113)
Weight	4.8 kg (10.6 lbs)
Design	Industrial enclosure with external DSL
Material	Aluminum with corrosion-resistant coating EN AC-43400 (AlSi10Mg (Fe))
Ingress protection	IP67/NEMA 4X to EN/IEC 60529 (1 mH <sub>2</sub> O for 30 min.)
Mechanical load	18 to 1000 Hz random, 3.17 g RMS, in all directions, to IEC 68-2-36

7.8 Construction

Table 7-23 Wall mount enclosure transmitter design

Description	Specification
Dimensions	See Transmitter (Page 113)
Weight	Transmitter (with internal DSL): 5.6 kg (12.3 lbs) Transmitter (without internal DSL): 4.9 kg (10.8 lbs) Display module: 0.095 kg (0.2 lbs) Input/output module: 0.090 kg (0.2 lbs)
Design	Wall mount enclosure with or without internal DSL
Material	Aluminum with corrosion-resistant coating EN AC-44300 (AlSi12Mg (Fe))
Ingress protection	IP66/67/NEMA 4X to EN/IEC 60529 (1 meter for 30 min)
Mechanical load	18 to 1000 Hz random, 3.17 g RMS, in all directions, to EN/IEC 68-2-36

Table 7-24 External DSL design

Description	Specification
Dimensions	See External DSL dimensions (Page 114)
Weight	2.5 kg (5.5 lbs)
Design	External DSL for pipe or wall mounting
Material	Aluminum with corrosion-resistant coating EN AC-43400 (AlSi10Mg (Fe))
Ingress protection	IP66/67/NEMA 4X to EN/IEC 60529 (1 meter for 30 min)
Mechanical load	18 to 1000 Hz random, 3.17 g RMS, in all directions, to EN/IEC 68-2-36

**Torques**

Table 7-25 Cable gland to enclosure installation torques (Siemens supplied, metric)

Description	Torque (Nm)
Plastic blind plugs	1.2
Plastic cable glands	4.5
Brass cable glands/blind plugs	10
Stainless steel cable glands/blind plugs	11

Table 7-26 Wall mount enclosure installation torques

Description	Torque (Nm)
Enclosure lid screws	6
Pipe mounting nuts	10

Table 7-27 Industrial enclosure installation torques

Description	Torque (Nm)
Wall bracket screws	10
Transmitter to wall bracket	25
Transmitter pedestal lock screw	10
Pedestal lock screw cap	10

**Note**

**NPT glands on wall mount enclosure**

When using NPT glands, the user must take care to use the supplied NPT thread adaptors.

## 7.9 Operating conditions

Table 7-28 Basic conditions

Description	Specification
Ambient temperature (Humidity max. 90 %)	Operation: Transmitter without display: -40 to +60 °C (-40 to +140 °F) Display: -20 to +60 °C (-4 to +140 °F)
Ambient temperature (Humidity max. 90 %)	Storage: -40 to +70 °C (-40 to +158 °F)
Climate class	DIN 60721-3-4
Altitude	Up to 2000 m (6560 ft)
Pollution wall mount enclosure	Degree 2
Relative humidity	95 %
Mechanical environment resistance class 4M3 for industrial enclosure	<ul style="list-style-type: none"> <li>IEC 60068-2-64 test Fh: Random vibration</li> <li>IEC 60068-2-27 test Ea and guidance: Impact</li> </ul>
Climatic resistance class 4K4H	<ul style="list-style-type: none"> <li>IEC 60068-2-2 test B: Dry heat</li> <li>IEC 60068-2-1 test A: Cold</li> <li>IEC 60068-2-78 test Cab: Damp heat, steady state</li> <li>IEC 60068-2-14 test N: Change of temperature</li> </ul>
EMC performance	<ul style="list-style-type: none"> <li>Emission</li> <li>Immunity</li> </ul>
	<ul style="list-style-type: none"> <li>EN 55011 / CISPR-11</li> <li>EN/IEC 61326-1 (Industry) NAMUR</li> </ul>

7.10 Cables and cable entries

Table 7-29 Process medium conditions

Description	Specification
Process medium temperature within the acceptable temperature range for the sensors	(-40 to 230 °C for High Temperature 991 sensors)
Fluid must be sonically conductive	-
Operation outside the Reynolds transition region for best accuracy	-

Table 7-30 Performance section

Description	Specification
Approvals	<ul style="list-style-type: none"> <li>• ATEX Zone 2</li> <li>• IECEx Zone 2</li> <li>• FM Class I Div. 2</li> <li>• FMc Class I Div. 2</li> </ul>
Accuracy	± 0.5 ... 1 % for velocities above 0.3 m/s and >10 diameters straight run
Repeatability	± 0.25 % (based on ISO 11631)
Pipe size range	12.7 ... 10 m (0.5 ... 394")
Wall Thickness Range	0.64 ... 76.2 mm (0.025 ... 3.0")
Pipe material	Any sonically conductive material (steel, plastic, aluminum, glass, cement, ductile iron, copper)

## 7.10 Cables and cable entries

Table 7-31 SSL cable, basic data

Description	Specification
Number of conductors	4
Square area [mm <sup>2</sup> ]	0.326 (AWG 22/7)
Screen	Yes
Outside color	<ul style="list-style-type: none"> <li>• Standard version: gray (RAL 7001)</li> <li>• Ex version: light-blue (RAL 5015)</li> </ul>
External diameter [mm]	6.5 (standard); 12 (armored)
Maximum length [m (ft.)]	75 (246)
Installation environment	Industrial including chemical processing plants
Insulation material	Special polyolefin
Halogen-free	Yes
RoHS compliant	Yes
Torsional strength	<ul style="list-style-type: none"> <li>• &gt;3 million cycles at ± 180° on 200 mm</li> <li>• Not adapted for garland mounting (festoon)</li> </ul>



Description	Specification
Permissible temperature range [°C (°F)]	-40 to +80 (-40 to +176)
Min. bending radius allowed	Single 5 X $\phi$

Table 7-32 Signal cable recommendations for channels 1 to 4

Description	Specification
Square area [mm <sup>2</sup> ]	0.5 (AWG 20)
Linear resistance [ $\Omega$ /km]	$\leq 120$
Max. length [ $\Omega$ ] (depends on total linear resistance)	< 500
Signal run time [ns/m]	$\leq 5.3$
Insulation resistance [M $\Omega$ *km]	$\geq 200$
Characteristic impedance 1 – 100 MHz [ $\Omega$ ]	100 ( $\pm 5$ )
Attenuation @ 1 MHz	< 2.9 dB/100 m
Operating voltage (peak) [V]	$\leq 300$
Test voltage (wire/wire/screen rms 50 Hz 1 min) [V]	= 700

Electrical data at reference temperature (20 °C)

Table 7-33 Power supply cable recommendations

Description	Specification
Square area [mm <sup>2</sup> ]	1.3 (AWG 16)
Max. length [m]	300 (AWG 16)

**Note**

Size the cable length and diameter to provide 20 V DC at power terminals at load current of 0.75 A

Table 7-34 Transmitter cable glands and entries

Description	Specification
Glands	<ul style="list-style-type: none"> <li>• Material                             <ul style="list-style-type: none"> <li>– Nylon<sup>1)</sup></li> <li>– Brass/Ni plated</li> <li>– Stainless steel AISI 316/1.4404</li> </ul> </li> <li>• Cable cross section                             <ul style="list-style-type: none"> <li>– <math>\phi</math> 8 to 17 mm (0.31" to 0.67")</li> <li>– <math>\phi</math> 5 to 13 mm (0.20" to 0.51")</li> </ul> </li> </ul>
Entries	9 x M20

<sup>1)</sup>: If operating temperature is below -20 °C (-4 °F), use Brass/Ni plated or stainless steel cable glands.

7.12 Approvals

**Cable glands and fittings for use in Explosive Atmospheres**

1. M20 to 1/2 NPT adaptors, M12 connector and plugs supplied by Siemens have been approved as part of the certification.
2. Cable glands shall be rated for a minimum ingress protection rating of IP54 and have an ambient temperature rating suitable for the installation with a safety factor of 5 °K above the maximum ambient.
3. The threads shall be M20 x 1.5. A sealing ring or gasket shall be used. Cable sizes of 5 to 14.3 mm may be used unless otherwise restricted by the manufacturer.
4. Cable glands for use in Zone 2 explosive atmospheres shall be rated Ex e as follows:
  - For use in US Zone 2 explosive atmospheres they shall be rated AEx ex or AEx eb. They shall also be rated for Enclosure Type 4.
  - For Canadian, IECEx or ATEX Zone 2 explosive atmospheres they shall be rated Ex ec or Ex eb.

**7.11 Certificates and approvals**

**Note**

**Device-specific approvals**

Always refer to nameplates on the device for device-specific approvals.

**7.12 Approvals**

Table 7-35 Ratings FST030 wall mount enclosure

<b>"Intrinsic safety" type of protection</b>	
Canada, USA	Class I, Division 2, Groups A, B, C, D
• FM17CA0110X	Class II, Division 2, Groups F, G
• FM17US0219X	Class III, Division 2
• CSA 21CA80072942X	Class I, Zone 2, AEx ia nA [ia Ga] IIC T6...T5 Gc Class I, Zone 2; AEx/Ex ec ia [ia Ga] IIC T6...T5 Gc Class II, Zone 22; AEx/Ex tc [ia Da] IIIC T85°C Dc
ATEX, UKEx, IECEx	II 3(1) G Ex ec ia [ia Ga] IIC T6...T5 Gc
• FM17ATEX0055X	II 3(1) D Ex tc [ia Da] IIIC T85°C Dc
• FM21UKEX0059X	
• IECEx FMG 17.0023X	
Inmetro	Ex ec ia [ia Ga] IIC T6 ... T5 Gc
• BRA 21.GE0021X	Ex tc [ia Da] IIIC T85°C Dc BRA 21.GE0021X
Ambient temperature range	T6 for -40 °C ≤ Ta ≤ 45 °C T5 for -40 °C ≤ Ta ≤ 60 °C T5 85 °C for -40 °C ≤ Ta ≤ 60 °C

Table 7-36 Ratings FST030 industrial enclosure

<b>"Intrinsic safety" type of protection</b>	
Canada, USA	<b>Canada:</b> Ex db eb ia [ia Ga] IIC T6 Gb Ex tb [ia Da] IIIC T85°C
<ul style="list-style-type: none"> <li>• CSA 2508628</li> <li>• FM18US0063X</li> <li>• FM21CA0019X</li> </ul>	<b>USA:</b> Class I, Division 1, Groups A, B, C, D Class II, Division 1, Groups E, F, G Class III, Division 1 Class I, Zone 1: AEx db eb ia [ia Ga] IIC T6 Gb Class II, Zone 21: AEx tb [ia Da] IIIC T85°C
ATEX, UKEx, IECEx	II 2(1) G Ex db eb ia [ia Ga] IIC T6 Gb II 2(1) D Ex tb [ia Da] IIIC T85°C Db
<ul style="list-style-type: none"> <li>• Sira 11ATEX1342X</li> <li>• CSAE 21UKEX1109X</li> <li>• IECEx SIR 11.0150X</li> </ul>	
Inmetro	Ex db eb ia [ia Ga] IIC T6 Gb Ex tb [ia Da] IIIC T85°C Db
<ul style="list-style-type: none"> <li>• BRA 22.GE0008X</li> </ul>	
Ambient temperature range	Ta = -40°C to 60°C

Table 7-37 Ratings FS230 external DSL

<b>"Intrinsic safety" type of protection</b>	
Canada, USA	IS Class I, Division 1, Groups A, B, C, D IS Class II, Division 1, Groups E, F, G IS Class III, Division 1
<ul style="list-style-type: none"> <li>• FM16CA0157X</li> <li>• FM16US0318X</li> <li>• CSA 21CA8007621X</li> </ul>	Class I, Zone 0; AEx/Ex ia IIC T6...T5 Ga Class II, Zone 21; AEx/Ex ib IIIC T64°C...T74°C Db
ATEX, UKEx, IECEx	II 1 G Ex ia IIC T6...T5 Ga II 2 D Ex ib IIIC T <sub>5</sub> 64°C...T <sub>5</sub> 74°C Db
<ul style="list-style-type: none"> <li>• FM16ATEX0094X</li> <li>• FM21UKEX0058X</li> <li>• IECEx FMG 16.0037X</li> </ul>	
Inmetro	Ex ia IIC T6...T5 Ga Ex ib IIIC T5 64°C Db
<ul style="list-style-type: none"> <li>• BRA 21.GE0014X</li> </ul>	
Ambient temperature range	T6: -40 °C ≤ Ta ≤ 50 °C T5: -40 °C ≤ Ta ≤ 60 °C T <sub>5</sub> 64 °C: -40 °C ≤ Ta ≤ 50 °C T <sub>5</sub> 74 °C: -40 °C ≤ Ta ≤ 60 °C

### Division 2, Zone 2, Zone 22 Installations

1. I/O shall be installed as intrinsically safe circuits.
2. Active circuits are associated apparatus to external intrinsically safe apparatus where  $U_i (V_{max}) \geq U_o (V_{oc} \text{ or } V_t)$ ;  $I_i (I_{max}) \geq I_o (I_{sc} \text{ or } I_t)$ ;  $P_i (P_{max}) \geq P_o$ ;  $C_o (C_a) \geq C_i + C_{cable}$ ;  $L_o (L_a) \geq L_i + L_{cable}$
3. Passive circuits and relays shall be connected to external associated apparatus where  $U_i (V_{max}) \geq U_o (V_{oc} \text{ or } V_t)$ ;  $I_i (I_{max}) \geq I_o (I_{sc} \text{ or } I_t)$ ;  $P_i (P_{max}) \geq P_o$ ;  $C_o (C_a) \geq C_i + C_{cable}$ ;  $L_o (L_a) \geq L_i + L_{cable}$

7.13 SensorFlash

**Ratings FSS200 sensor**

<b>"Intrinsic safety" type of protection</b>	
Canada, USA	Class I, Division 1, Groups A, B, C, D
• FM16CA0142X	Class II, Division 1, Groups E, F, G
• FM16US0280X	Class III
• CSA 80083297X	Class I, Zone 0, AEx/ Ex ia IIC T6 ... T4 Ga Class II, Zone 21 AEx/ Ex ib IIIC T70°C ... T110°C Db
ATEX, UKEx, IECEx	II 1G Ex ia IIC T6...T4 Ga
• IECEx FMG 17.0004X	II 2D Ex ib IIIC T70 – 110 °C Db
• FM 16ATEX0090X	
• FM21UKEX0057X	
Inmetro	Ex ia IIC T6...T4 Ga
• BRA 21.GE0013X	Ex ia IIIC T70°C...110°C Da
Temperature code	Varies by sensor and ambient temperature (see Sensor installation in hazardous areas (Page 14))
Dust Temperature class	Tdust = Ta max + 10 °K (T70 °C for Ta = 60 °C, T110 °C for Ta = 100 °C)

**7.13 SensorFlash**

Table 7-38 SensorFlash

<b>Description</b>	<b>Specification</b>
	<b>SD card (S-300u)</b>
Capacity	4 GB
File system support	FAT32 / 8.3
Temperature range	
Operation:	-40 to +85 °C (-40 to 185 °F)
Storage:	-40 to +100 °C (-40 to 212 °F)

**Note**

**SensorFlash functions support**

Only the supplied 4 GB SD cards are supported for backup, restore, logging, and firmware update.

## Dimension drawings

### 8.1 Transmitter

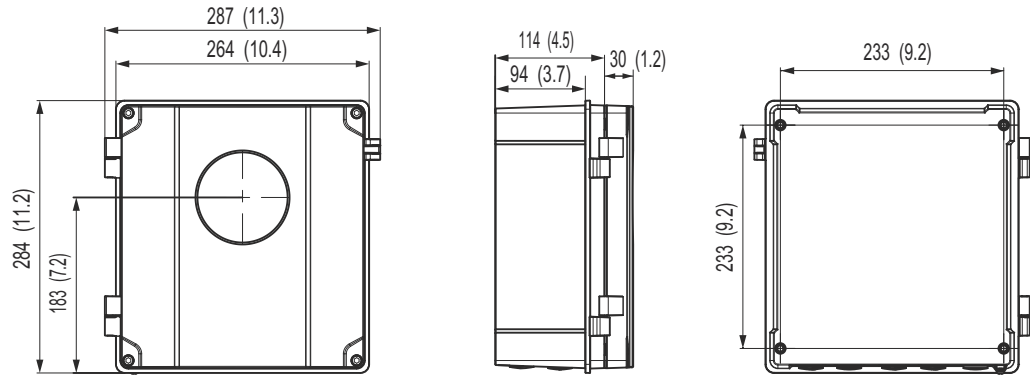
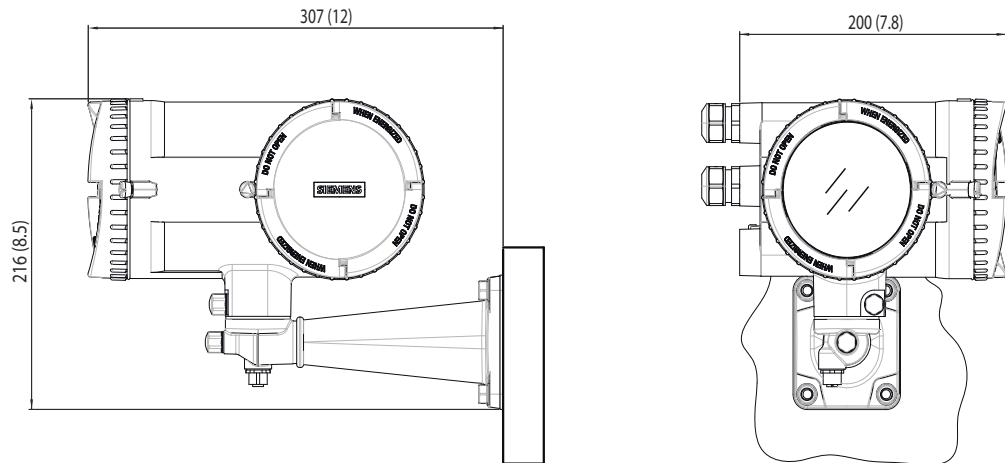

Figure 8-1 Transmitter dimensions in mm (")

#### 8.1.1 Industrial enclosure dimensions

##### Remote version



Dimensions in mm

## 8.2 Mounting bracket dimensions

### Industrial enclosure

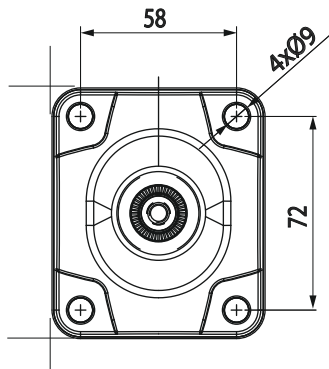

Dimensions in mm

Weight: 4.8 kg (10.6 lbs)

## 8.3 External DSL dimensions

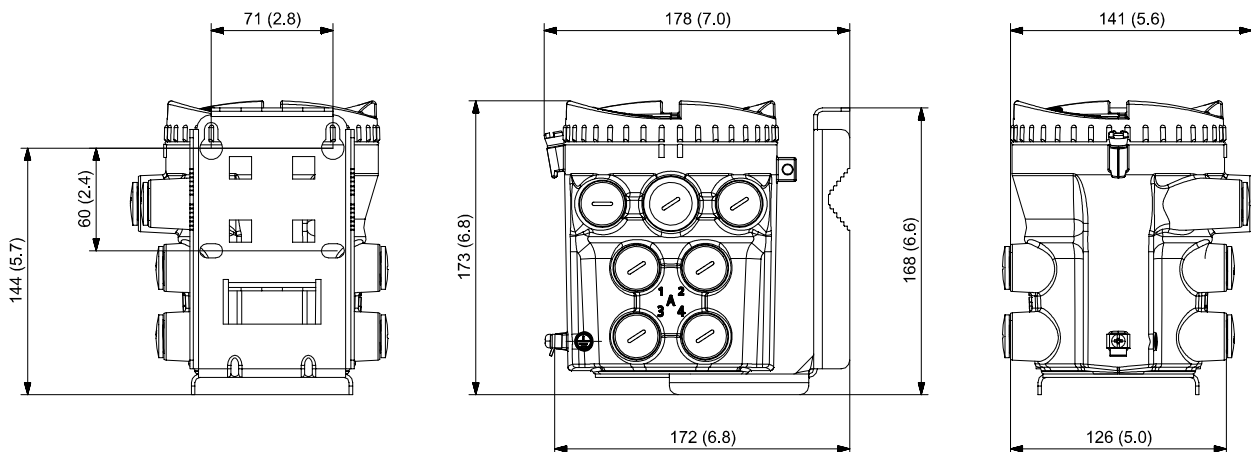

Figure 8-2 DSL dimensions in mm (")

# Product documentation and support

## A.1 Product documentation

Process instrumentation product documentation is available in the following formats:

- Certificates (<http://www.siemens.com/processinstrumentation/certificates>)
- Downloads (firmware, EDDs, software) (<http://www.siemens.com/processinstrumentation/downloads>)
- Catalog and catalog sheets (<http://www.siemens.com/processinstrumentation/catalogs>)
- Manuals (<http://www.siemens.com/processinstrumentation/documentation>)  
You have the option to show, open, save, or configure the manual.
  - "Display": Open the manual in HTML5 format
  - "Configure": Register and configure the documentation specific to your plant
  - "Download": Open or save the manual in PDF format
  - "Download as html5, only PC": Open or save the manual in the HTML5 view on your PC

You can also find manuals with the Mobile app at Industry Online Support (<https://support.industry.siemens.com/cs/ww/en/sc/2067>). Download the app to your mobile device and scan the device ID link.

### Product documentation by serial number

Using the PIA Life Cycle Portal, you can access the serial number-specific product information including technical specifications, spare parts, calibration data, or factory certificates.

#### Entering a serial number

1. Open the PIA Life Cycle Portal (<https://www.pia-portal.automation.siemens.com>).
2. Select the desired language.
3. Enter the serial number of your device. The product documentation relevant for your device is displayed and can be downloaded.

To display factory certificates, if available, log in to the PIA Life Cycle Portal using your login or register.

#### Scanning an ID link

1. Scan the ID link on your device with a mobile device.
2. Click "PIA Portal".

To display factory certificates, if available, log in to the PIA Life Cycle Portal using your login or register.

## A.2 Technical support

### Technical support

If this documentation does not completely answer your technical questions, you can enter a Support Request (<http://www.siemens.com/automation/support-request>).

For help creating a support request, view this video here.

Additional information on our technical support can be found at Technical Support (<http://www.siemens.com/automation/csi/service>).

### Service & support on the Internet

In addition to our technical support, Siemens offers comprehensive online services at service & support (<http://www.siemens.com/automation/service&support>).

### Contact

If you have further questions about the device, contact your local Siemens representative, by doing the following:

1. Visit Contact at Siemens (<http://www.automation.siemens.com/partner>).
2. Select "All Products and Branches" > "Products & Services" > "Industrial automation".
3. Choose either "Process analytics" or "Process instrumentation", depending on your product.
4. Select the product category ("Pressure measurement", for example), then select your product.
5. Click "Search".  
The contacts for your product in all regions display.

Contact address for business unit:

Siemens AG  
Digital Industries  
Process Automation  
Östliche Rheinbrückenstr. 50  
76187 Karlsruhe, Germany



# Index

## A

Approvals, 110, 111, 112

## C

Cable specifications, 108

Catalog

catalog sheets, 115

Certificates, 11, 115

Channels 5 and 6 input, 99

Cleaning, 92

Connecting

Channels 2 to 4, 63

HART, 61

Power supply (Industrial enclosure), 63

Current input, 98

Current output, 99

Customer Support, (Refer to Technical support)

## D

Design

Industrial enclosure transmitter design, 105

Wall mount enclosure transmitter, 106

Designated use, 105

Digital input, 98

Digital output, 101

Disassembly, 34

Disposal, 95

Downloads, 115

## E

Electrical connection

Wiring, 42

## H

HART

connecting, 61

HART communication, 97

Hazardous area

Laws and directives, 11

Qualified personnel, 13

Hazardous locations

Approvals, 14

Hotline, (Refer to Support request)

## I

Installation

Transmitter mounting, 26

Installation torques, 106, 107

Interface

HART communication, 97

Modbus communication, 98

## L

Laws and directives

Disassembly, 11

Personel, 11

Local display

Turning, 27

## M

Mains supply, 38

Maintenance, 94

Manuals, 115

Modbus communication, 98

Modifications

correct usage, 11

improper, 11

## O

Operating conditions

Basic conditions, 107

Performance section, 108

Process medium conditions, 108

## P

Power supply, 97

## Q

Qualified personnel, 13

## R

Reflect Mount, 32  
Relay output, 101  
Return procedure, 94

## S

Scope of delivery, 9  
SensorFlash, 112  
Service, 116  
Service and support  
    Internet, 116  
Support, 116  
Support request, 116  
Symbols, (Refer to warning symbols)  
System design, 105

## T

Technical data, 97, 112  
    Approvals, 110, 111, 112  
    Current input, 98  
    Current output, 99  
    Designated use, 105  
    Digital input, 98  
    Digital output, 101  
    input, 99  
    Installation torques, 106  
    Interface, 97, 98  
    Operating conditions, 107  
    Relay output, 101  
    System design, 105  
Technical support, 116  
    partner, 116  
    personal contact, 116  
Tehcnical data  
    Power supply, 97  
Test certificates, 11  
Transmitter  
    Mounting, 26  
    Pipe mounting, 25  
    Wall mounting, 25, 29

## W

Wall Mounted Transmitter, 41  
Warning symbols, 11  
Warranty, 10