



ENGINEERING **YOUR** SUCCESS.

AQUA DUO – A455C

(2800 – 6800 GPD)

Technical Manual



Parker – Water Purification

2630 E. El Presidio Street

Carson, CA 90810

www.parker.com/waterpurification

REVISION HISTORY

REV	DATE	DESCRIPTION	AUTHOR
-	March, 2022	INITIAL RELEASE	OM
A	October, 2022	DIAGRAM AND DRAWING UPDATES	OM & JT

The following are the types of flags used in this technical manual. They designate safety related items and important operational instructions and should be given special attention when they appear in the text:

WARNING

Text formatted in this manner concerns an operating procedure or practice that, if not strictly observed, can result in injury to personnel or loss of life.

CAUTION

Text formatted in this manner concerns an operating procedure or practice that, if not strictly observed, can result in damage to or destruction of equipment.

NOTE

Text formatted in this manner concerns an operating procedure or condition that warrants special attention.

TABLE OF CONTENTS

Contents

1.0	SYSTEM DESCRIPTION:	5
1.1.	SYSTEM SPECIFICATIONS:.....	5
1.2.	UTILITY REQUIREMENTS	5
1.3.	RECOMMENDED SPARE PARTS LIST	6
1.4.	SPECIAL TOOLS LIST.....	6
1.5.	PHYSICAL CHARACTERISTICS	7
2.0	PRE-INSTALLATION NOTES	9
2.1	PRECAUTIONS.....	9
2.2	RO SYSTEM LOCATION	9
2.3	INSTALLING THE SYSTEM.....	10
2.4	COMPONENTS.....	12
2.5	MOUNTING COMPONENTS	19
2.6	ELECTRICAL CONNECTIONS.....	31
2.7	PLUMBING CONNECTIONS	31
3.0	THEORY OF OPERATION AND GENERAL DESCRIPTION	35
3.1	REVERSE OSMOSIS THEORY	35
3.2	PRODUCT WATER QUALITY STANDARDS.....	36
3.3	FACTORS AFFECTING PERMEATE PRODUCTION.....	37
3.4	TEMPERATURE CORRECTION FACTOR.....	38
3.5	CONTROLS AND INSTRUMENTATION	39
3.6	RO FILTRATION SYSTEM DESCRIPTION	39
3.7	REVERSE OSMOSIS SYSTEM	39
3.8	PRODUCT MONITORING SYSTEM.....	40
3.9	FRESH WATER FLUSH SYSTEM	40
3.10	HUMAN-MACHINE INTERFACE (HMI).....	40
4.0	COMMISSIONING	41
4.1	COMMISSIONING CHECKLIST.....	41
4.2	Pressure Changes.....	44
5.0	OPERATIONS	48

5.1	System Operation Notes.....	48
5.2	Operation Cautions.....	48
5.3	Startup Procedure	49
5.4	High/Low Pressure Fault Lamp Explanation.....	49
5.5	Controller Operations	50
6.0	MAINTENANCE & REPAIR.....	53
6.1	GENERAL	53
6.2	MICRON FILTER ELEMENT REPLACEMENT	53
7.0	TROUBLESHOOTING.....	54
7.1	System Shuts Down During Operation	54
7.2	Product Water Flow and Product Water Quality	56
7.3	3-way Product Water Diversion Valve Abnormalities.....	58
7.4	Booster Pump Abnormalities	60

1.0 SYSTEM DESCRIPTION:

1.1. SYSTEM SPECIFICATIONS:

PART NUMBER	VOLTAGE 50/60 HZ - 1/3PH	PRODUCT CAPACITY GPD/LPD	PRODUCT CAPACITY GPH/LPH	DRY WEIGHT	WET WEIGHT	MEMBRANE P/N
A455C-2800	110/220/380/440 AC	2800 GPD (10599 LPD)	117 GPH (441 LPH)	570 lbs. (258 kg)	591 lbs. (269 kg)	4x 2724011333
A455C-3600	110/220/380/440 AC	3600 GPD (13627LPD)	150 GPH (568 GPH)	601 lbs. (272 kg)	591 lbs. (269 kg)	4x 2724011433
A455C-4400	110/220/380/440 AC	4400 GPD (19684 LPD)	183 GPH (694 GPH)	601 lbs. (272 kg)	623 lbs. (283 kg)	6x 2724011333
A455C-5200	110/220/380/440 AC	5200 GPD (19680 LPD)	217 GPH (820 GPH)	650 lbs. (296 kg)	676 lbs. (307 kg)	6x 2724011433
A455C-5800	110/220/380/440 AC	5800 GPD (21198LPD)	241 GPH (883 GPH)	700 lbs. (319 kg)	728 lbs. (331 kg)	8x 2724011333
A455C-6800	110/220/380/440 AC	6800 GPD (25741LPD)	283 GPH (1073 GPH)	750 lbs. (342 kg)	780 lbs. (355 kg)	8x 2724011433

Table 1.0 - Performance Specification

*Production May Vary +-20% | GPD: Gallons per Day, LPD: Liters per day, GPH: Gallons per Hour, & LPH: Liters per Hour

Parameter for All Aqua Duo Systems	Specification
Sea Water Feed Inlet water quality	Open Ocean
Sea Water Feed TDS:	Less than 42,000 ppm TDS
Product Water TDS:	<500 PPM TDS, WHO standard
Seawater Temperature Range:	0 °C to 32 °C (32-90°F)
Design Product Water Pressure:	2.07 BAR (30 PSI)
Max. Operating Pressure:	70 BAR (1000 PSI)

Table 1.1: Parameter Specification

1.2. UTILITY REQUIREMENTS

TIE	DESCRIPTION	CONNECTION
1001	FEED WATER INLET - UNIT A	3/4"NYLON PVC HOSE BARB
1002	PRODUCT WATER OUTLET – UNIT A	3/8" PP TUBE CONNECT
1003	REJECT OUTLET	3/4" NYLON PVC HOSE BARB
1004	FRESH WATER INLET – UNIT A	3/8" PP TUBE CONNECT
1005	FEED WATER INLET - UNIT B	3/4" NYLON PVC HOSE BARB
1006	PRODUCT WATER OUTLET- UNIT B	3/8" PP TUBE CONNECT
1007	FRESH WATER INLET- UNIT B	3/8" PP TUBE CONNECT
1008	MEDIA FILTER REJECT OUTLET	3/4"NYLON PVC HOSE BARB
1009		

TIE	DESCRIPTION	CONNECTION
1010		
1011		
1012		

Table 1.2: TIE CONNECTIONS

System	Single Unit Operation of HP Pump	Single Unit Operation of Booster Pump
A455C-2800	2.5 HP / 1.84 kW	0.5 HP / 0.37 kW
A455C-3600	2.5 HP / 1.84 kW	2 HP / 1.47 kW
A455C-4400	5 HP / 3.68 kW	2 HP / 1.47 kW
A455C-5200	5 HP / 3.68 kW	2 HP / 1.47 kW
A455C-5800	5 HP / 3.68 kW	2 HP / 1.47 kW
A455C-6800	5 HP / 3.68 kW	2 HP / 1.47 kW

Table 1.3: Pump Horsepower Requirement

NOTE

System contains **two units**. Operating both units simultaneously will require double the Horsepower/Kilowattage.

1.3. RECOMMENDED SPARE PARTS LIST

Spare Parts and Special Tools	Part Number
Filter, 32.5 Ft ² , 5-Micron	0801063357
Filter, 32.5 Ft ² , 20-Micron	0801133257
Carbon Flushing Filter	33-0311
Filter, AIR/OIL & WATER SERPARTOR	08020723KD
Vessel Membrane for 2800, 4400, & 5800 GPD Systems	2724011333
Vessel Membrane for 3600, 5200, & 6800 GPD Systems	2724011333

Table 1.4: Recommended Spare Parts

1.4. SPECIAL TOOLS LIST

SPECIAL TOOLS	Part No.
Solution, Calibration, 30,000 PPM	90-1301
Meter, Ultra, 4p, TDS	3131420156

Table 1.5: Special Tools

1.5. PHYSICAL CHARACTERISTICS: INCHES [MILIMETER]

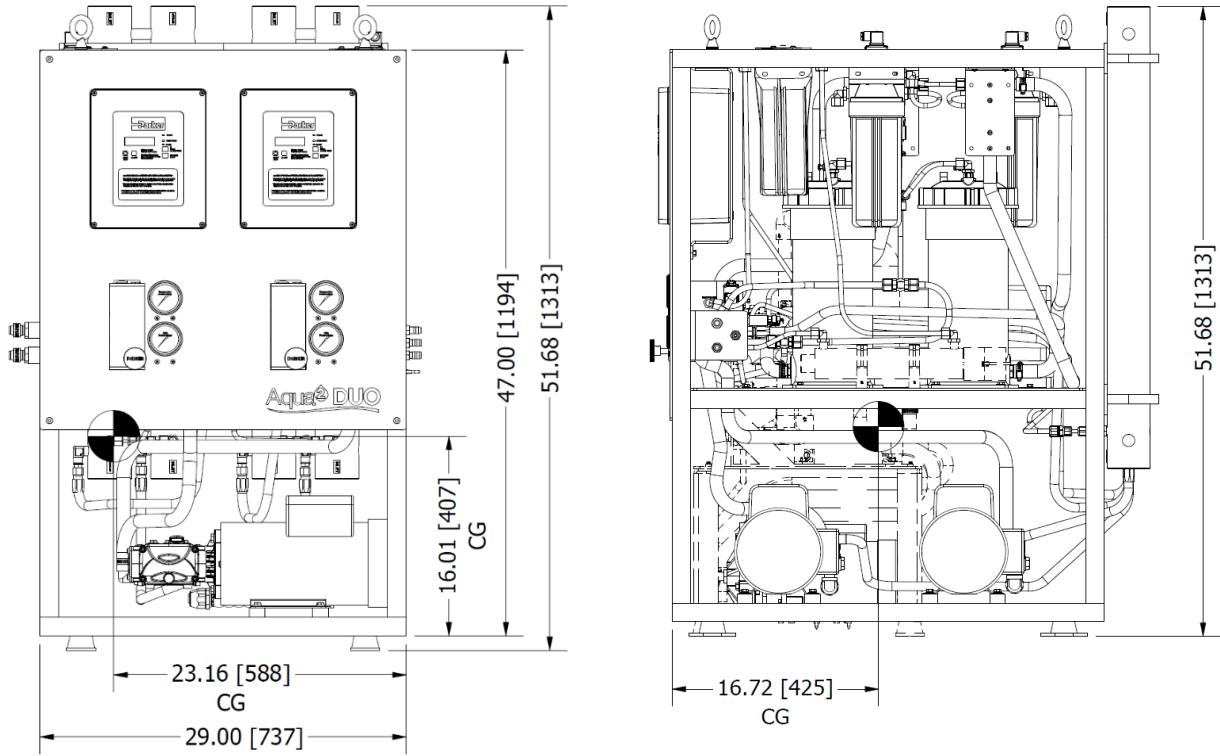

Figure 1.0: 2800-3600 GPD RO System Dimensions

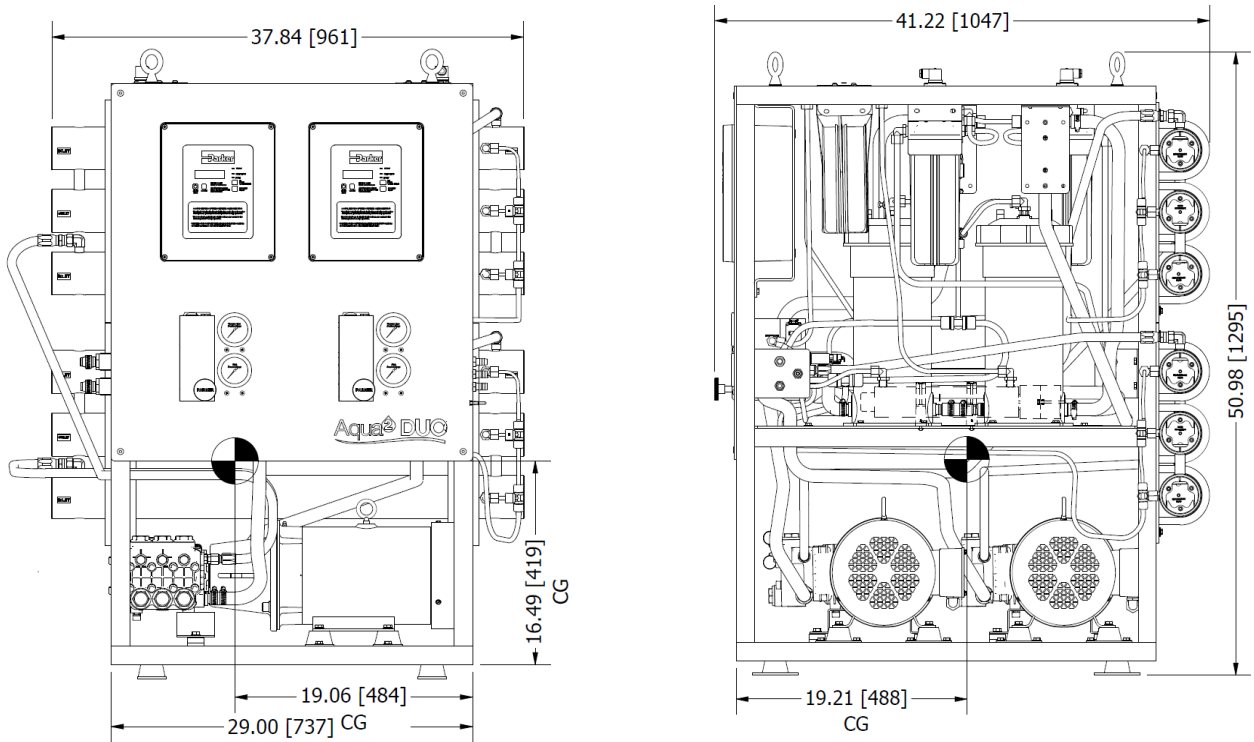

Figure 1.1: 4400 & 5800 GPD RO System Dimensions

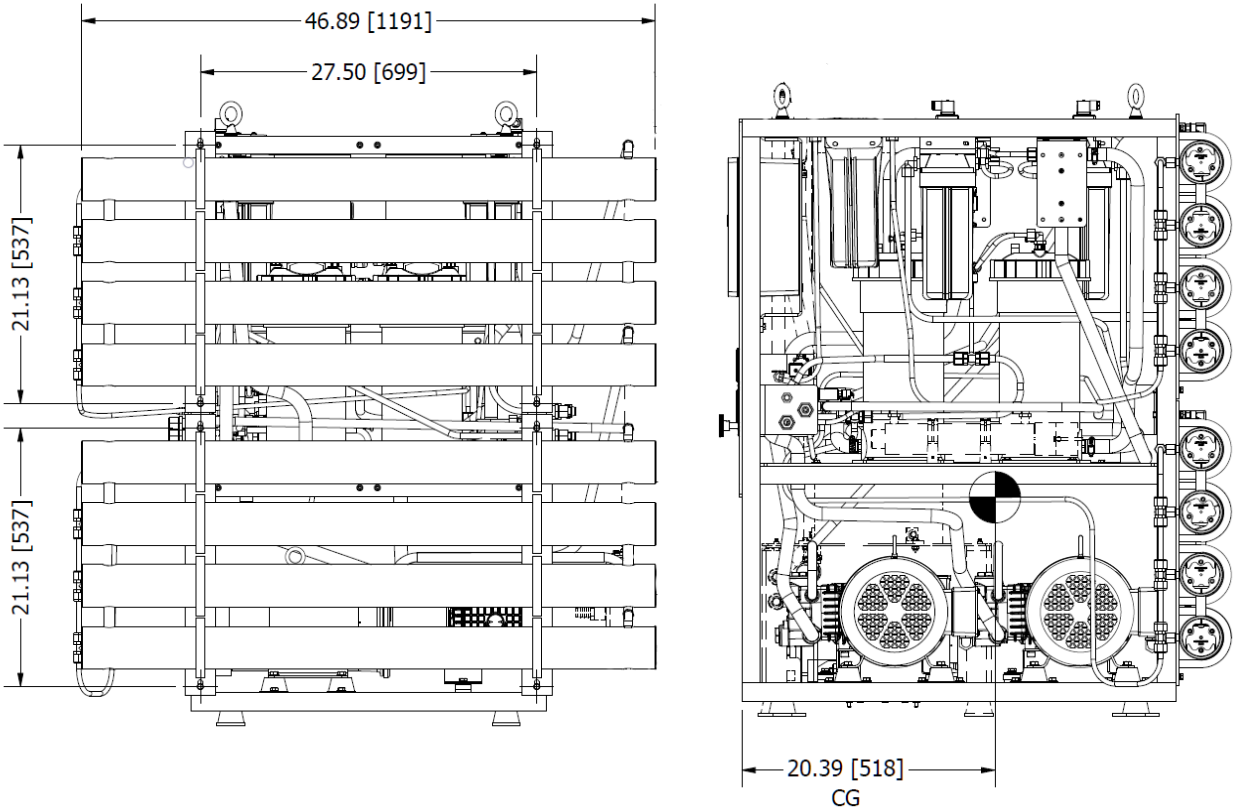

Figure 1.2: 5200 & 6800 GPD RO System Dimensions

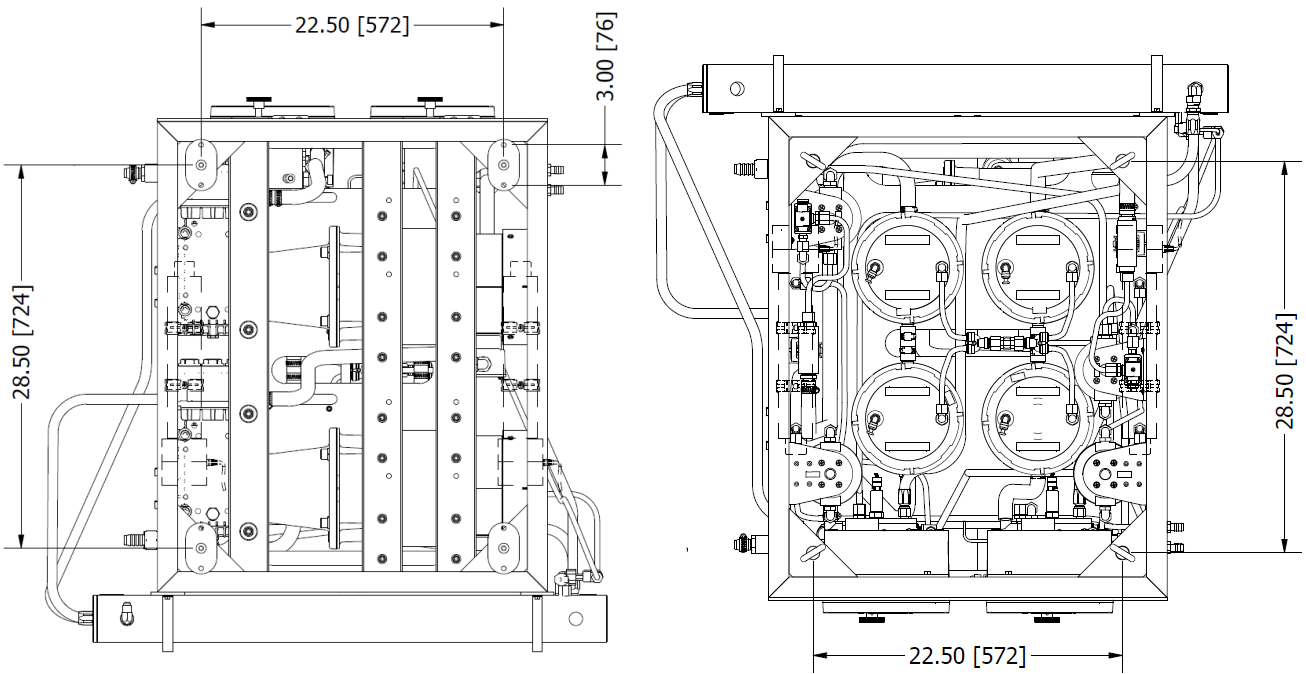

Figure 1.3: Mounting and Lifting lugs Dimensions of RO System

2.0 PRE-INSTALLATION NOTES

2.1 PRECAUTIONS

Reverse Osmosis (RO) System storage prior to uncrating:

CAUTION

DO NOT store in direct sunlight.

DO NOT store above 103 degrees F (39 degrees C).

DO NOT freeze.

CAUTION

If the RO system has been shipped new with Reverse Osmosis Membrane Elements installed, the System must be commissioned within 3 months. This is to avoid drying out or biological fouling of the RO membranes.

2.2 RO SYSTEM LOCATION

The RO unit should be installed in a dry, sheltered location protected from direct weather. Some type of drainage should be provided beneath the RO unit to allow standing water to drain when performing maintenance or repair.

The following two diagrams that show the RO System located relative to the seawater level. The first shows the RO System installation below water line and the second shows the RO System installation above water line.

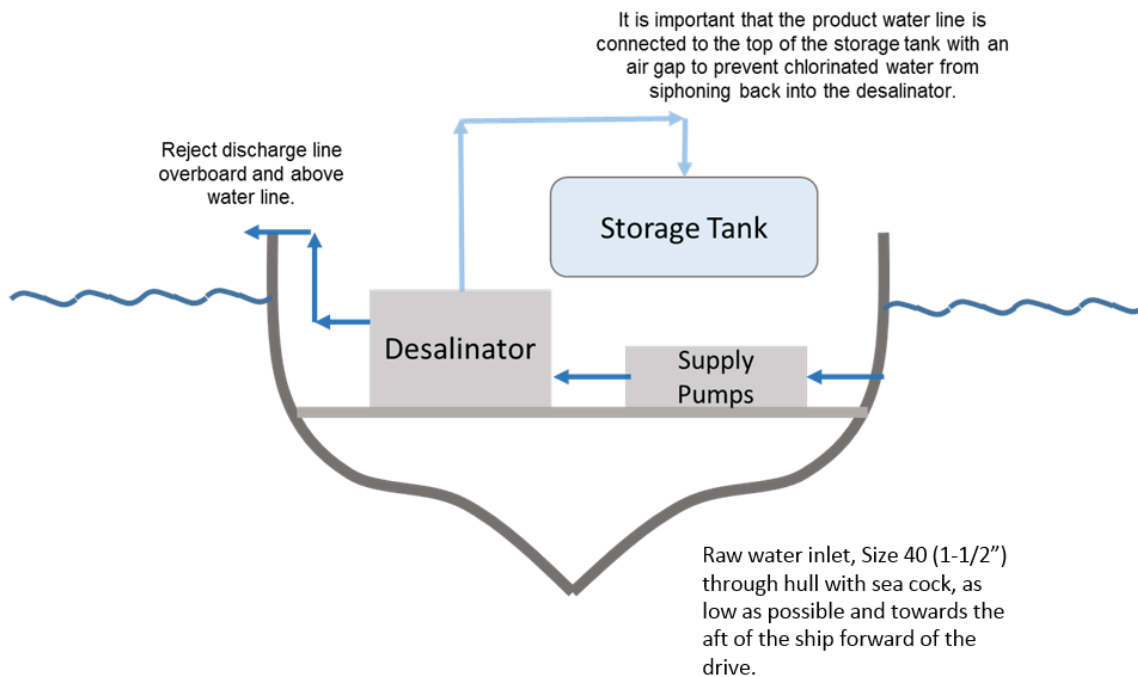

Figure 2.1 – RO Below Water Line

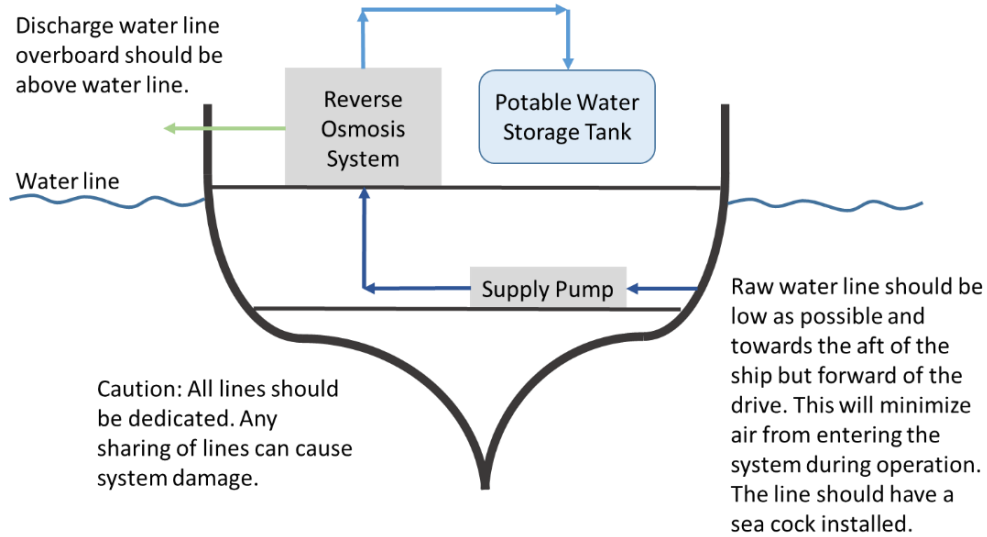

Figure 2.2: RO System Above Water Line

2.3 INSTALLING THE SYSTEM

Since every installation is unique, the mounting instructions are provided for guidance only. It is recommended that you use your own discretion as to the exact method of mounting and placement of any mounting bolts.

- 1) Mount the RO unit securely. Secure each skid in place using vibration isolators as required. Follow the maintenance envelope provided in the General Arrangement drawing.

CAUTION

All mounting surfaces must be flat to avoid warping of brackets and frames. Grind flat or use of appropriate shims on uneven surfaces to ensure that mounting of the system components does not cause bending or warping. Any damage caused by attaching the system or its components to an uneven surface is attributed to improper installation, is the liability of the installer, and is not covered by the Parker Hannifin warranty.

- 2) Make the following plumbing connections to the RO unit's piping interfaces provided on the General Arrangement drawing.

CAUTION

Inlet and discharge interconnecting lines must be constructed of a NON-FERROUS material. Examples of some suitable materials are PVC, copper-nickel, 316 stainless steel pipe or a reinforced non-collapsing hose. Ferrous piping produces rust that will irreversibly foul the membrane and void the RO unit warranty.

- a) Connect the sea water supply to a clean seawater source using a flexible connection to the unit.

CAUTION

Avoid connecting the inlet piping to any water line that services any other piece of equipment. Air could be drawn through the RO unit causing damage to the RO unit's pumps. Any air suction leaks coming into the system feed line may cause the system to shut down due to low feed pressure. If possible, plumb the feed line at the bottom of the Sea Chest. This ensures an uninterrupted supply of air free seawater.

- b) Connect the reject discharge (concentrate flow), to an unobstructed line using a flexible connection. The reject should be discharged overboard above the waterline.

CAUTION

The use of galvanized steel for product piping should be avoided as small amounts of rust may form that can be drawn back into the RO when the system is off.

- c) Connect the product water discharge using a flexible connection to an unobstructed line that is connected to the TOP of the product water storage tank. If the storage tank water is chlorinated, a check valve or air gap should be installed in the product line as a precaution to prevent chlorine damage of the RO membranes. The air gap is often accomplished by teeing the product connection to a tank vent or tank fill line of suitable size.

CAUTION

Exposing the membranes to chlorinated water may cause irreversible damage and will void the RO unit warranty.

- 3) Connect the following RO unit's electrical interfaces:

CAUTION

Strictly observe all applicable electrical codes and regulations governing the installation and wiring of electrical equipment. Never connect the RO unit to a line that services another electrical device. The RO unit should have its own dedicated power supply and breaker.

WARNING

DISCONNECT ELECTRICAL POWER TO RO UNIT AND THE POWER SOURCE BEFORE WORKING ON THE RO UNIT. FAILURE TO DO SO CAN CAUSE SERIOUS INJURY OR DEATH TO PERSONNEL.

- 4) Motor rotation. The Booster Pump and the High-Pressure Pump has proper markings to determine rotation.

CAUTION

Do not run high-pressure pump without water adequate flow and pressure. High-pressure pump will be damaged.

- 5) Connect a suitable ground to the RO unit skid, as determined by the specifics of your installation.

CAUTION

The pumps may be isolated from the ship's bonding system because of the protective coating applied to the pumps and their attached motor. As such, there may be no continuity between the pumps and the ship's bonding system. The path of stray current from the electric motors may be through the Feedwater Line. This is especially true if the electric motor grounding wire is insufficient. If left unbonded, the pumps become sacrificial and corrosion by electrolysis takes effect and destroys the pump manifolds, chambers, and impellers. Such destruction can render these pumps inoperable within just a few short months. The System Warranty does not cover damage resulting from electrolysis or improper or inadequate grounding.

2.4 COMPONENTS

All components supplied by Parker, both standard and optional, are described in this section along with items required or desired by the installer. The location, operation, and purpose of each major component are briefly explained in this section.

Each component in this manual is given an ID-number or "CALLOUT." A components list of the Aqua Duo which details the function and description of each "CALLOUT" can be found in Table 2.1. In addition, a detailed Piping & Instrumentation Diagram of each system capacity can be found in Figure 2.4 through 2.7.

NOTE

THE AQUA DUO IS DESIGNED AS A TWO-UNIT REDUNDANCY SYSTEM. BOTH RO UNITS (A & B) ARE INDEPENDENT OF EACH OTHER AND CAN RUN SIMULTANEOUSLY TOGETHER OR SEPARATELY FROM ONE ANOTHER.

NOTE

TO PRODUCE THE FULL CAPACITY OF THE SYSTEM, THE TWO UNITS (UNIT A & UNIT B) MUST OPERATE SIMULTANEOUSLY.

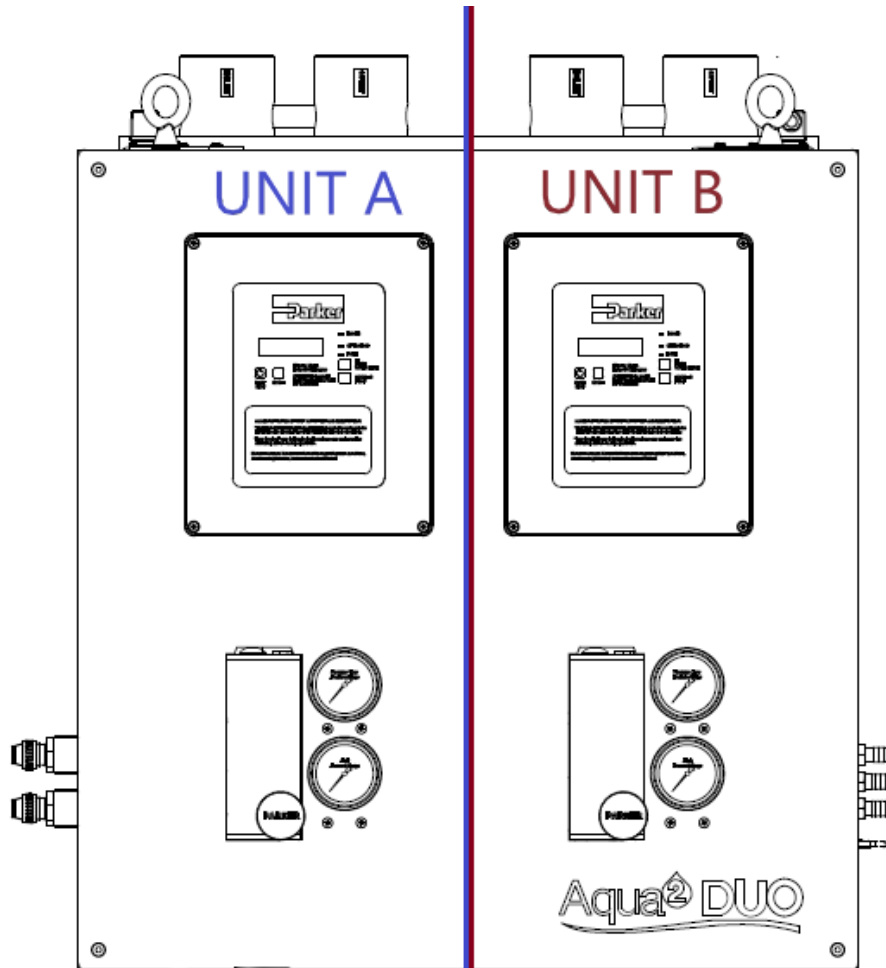

Figure 2.3: Illustration of Unit A and Unit B Controls

Components List:

CALLOUT	DISCRIPTION	FUNCTION
AWPC-1 & AWPC-2	MAIN CONTROLLER	CONTROLS OPERATION OF UNIT
BP-1	BOOSTER PUMP MOTOR ASSY FOR UNIT A	PROVIDES INLET PRESSURE TO UNIT
BP-2	BOOSTER PUMP MOTOR ASSY FOR UNIT B	PROVIDES INLET PRESSURE TO UNIT
CF-1	CHARCOAL FILTER FOR UNIT A	REMOVES CHLORINE AND ORGANIC COMPOUNDS
CF-2	CHARCOAL FILTER FOR UNIT B	REMOVES CHLORINE AND ORGANIC COMPOUNDS
CV-1	CHECK VALVE TEE- FOR UNIT A	STOPS BACK FLOW OR ALLOWS FLOW IN ONE DIRECTION
CV-2	CHECK VALVE TEE- FOR UNIT B	STOPS BACK FLOW OR ALLOWS FLOW IN ONE DIRECTION
FIL-1	5-MICRON PRE-FILTER- FOR UNIT A	REMOVES PARTICLES LARGER THAN 5-MICRONS
FIL-2	5-MICRON PRE-FILTER- FOR UNIT B	REMOVES PARTICLES LARGER THAN 5-MICRONS

FIL-3	Optional 20-MICRON PRE-FILTER- FOR UNIT A	REMOVES PARTICLES LARGER THAN 20-MICRONS
FIL-4	Optional 20-MICRON PRE-FILTER- FOR UNIT B	REMOVES PARTICLES LARGER THAN 20-MICRONS
FWF-1	FRESH WATER FILTER- FOR UNIT A	REMOVES CHLORINE
FWF-2	FRESH WATER FILTER- FOR UNIT B	REMOVES CHLORINE
HP-1	HIGH PRESSURE PUMP MOTOR ASSY- FOR UNIT A	PROVIDES MEMBRANES WITH HIGH PRESSURE
HP-2	HIGH PRESSURE PUMP MOTOR ASSY- FOR UNIT B	PROVIDES MEMBRANES WITH HIGH PRESSURE
M1	HIGH PRESSURE MOTOR FOR UNIT A	ROTATES HIGH PRESSURE PUMP
M2	HIGH PRESSURE MOTOR FOR UNIT B	ROTATES HIGH PRESSURE PUMP
M3	BOOSTER MOTOR FOR UNIT A	ROTATES BOOSTER PUMP
M4	BOOSTER MOTOR FOR UNIT B	ROTATES BOOSTER PUMP
MF-1	MANIFOLD ASSY-1 FOR UNIT A	CONNECTS UNIT PLUMBING AND INSTRUMENTATION
MF-2	MANIFOLD ASSY-2 FOR UNIT B	CONNECTS UNIT PLUMBING AND INSTRUMENTATION
MMF-1	MEDIA FILTER ASSY-1 FOR UNIT A	PROVIDES PREFILTRATION FOR LARGE PARTICLES
MMF-2	MEDIA FILTER ASSY-2 FOR UNIT B	PROVIDES PREFILTRATION FOR LARGE PARTICLES
OWS-1	AIR/OIL WATER SEPARATOR- FOR UNIT A	SEPARATES OIL AND AIR FROM THE INLET WATER
OWS-2	AIR/OIL WATER SEPARATOR- FOR UNIT B	SEPARATES OIL AND AIR FROM THE INLET WATER
P1	HIGH PRESSURE PUMP FOR UNIT A	PROVIDES SYSTEM WITH HIGH PRESSURE
P2	HIGH PRESSURE PUMP FOR UNIT B	PROVIDES SYSTEM WITH HIGH PRESSURE
P3	BOOSTER PUMP FOR UNIT A	PROVIDES SYSTEM WITH INLET PRESSURE
P4	BOOSTER PUMP FOR UNIT B	PROVIDES SYSTEM WITH INLET PRESSURE
PG-1-1 & PG-2-1	LOW PRESSURE GAGE	MEASURES INLET PRESSURE WITH RANGE 0-300 PSI
PG-1-2 & PG-2-2	HIGH PRESSURE GAGE	MEASURES HIGH PRESSURE OF SYSTEM WITH RANGE OF 0-2000
PV-1 & PV-2	PRESSURE VESSELS (ALL CAPACITIES) - FOR UNIT A	PRESSURIZES AND STORES MEMBRANES TO PRODUCE POTABLE WATER
PV-3 & PV-4	PRESSURE VESSELS- FOR UNIT A (4200-6800 GPD SYSTEMS)	PRESSURIZES AND STORES MEMBRANES TO PRODUCE POTABLE WATER
PV-5 & PV-6	PRESSURE VESSELS (ALL CAPACITIES) - FOR UNIT B	PRESSURIZES AND STORES MEMBRANES TO PRODUCE POTABLE WATER
PV-7 & PV-8	PRESSURE VESSELS- FOR UNIT B (4200-6800 GPD SYSTEMS)	PRESSURIZES AND STORES MEMBRANES TO PRODUCE POTABLE WATER
ST-1	STRAINER- FOR UNIT A	STRAINES AWAY THE IMPPURITIES AT THE INITIAL STAGE
ST-2	STRAINER- FOR UNIT B	STRAINES AWAY THE IMPPURITIES AT THE INITIAL STAGE
UV-1	OPTIONAL UV STERILIZER- FOR UNIT A	KILLS BIOLOGICAL GROWTH USING UV RADIATION
UV-2	OPTIONAL UV STERILIZER- FOR UNIT B	KILLS BIOLOGICAL GROWTH USING UV RADIATION

Table 2.1: Components Table List

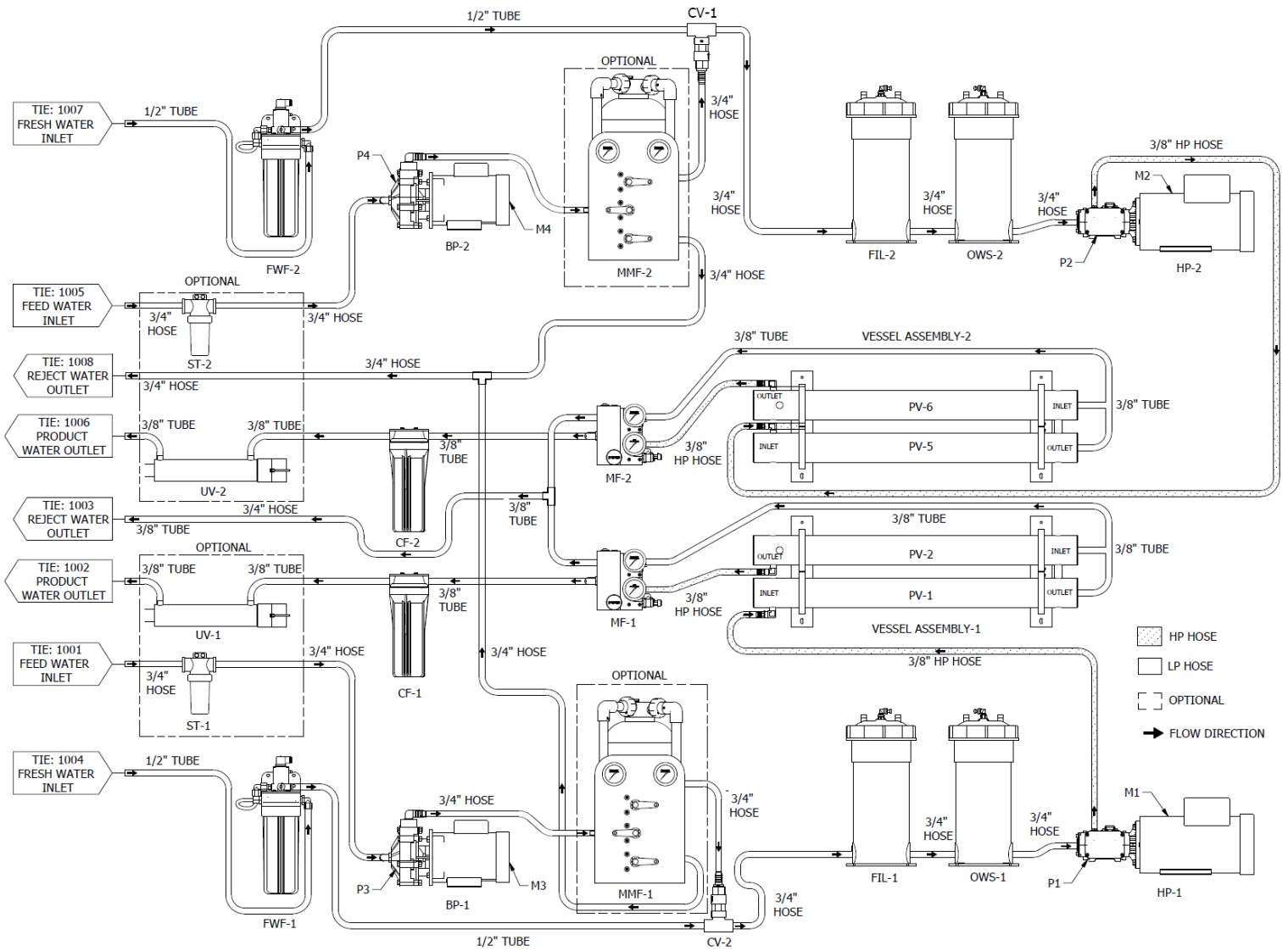

Figure 2.4: Piping and Instrumentation Diagram 2800-3600 GPD

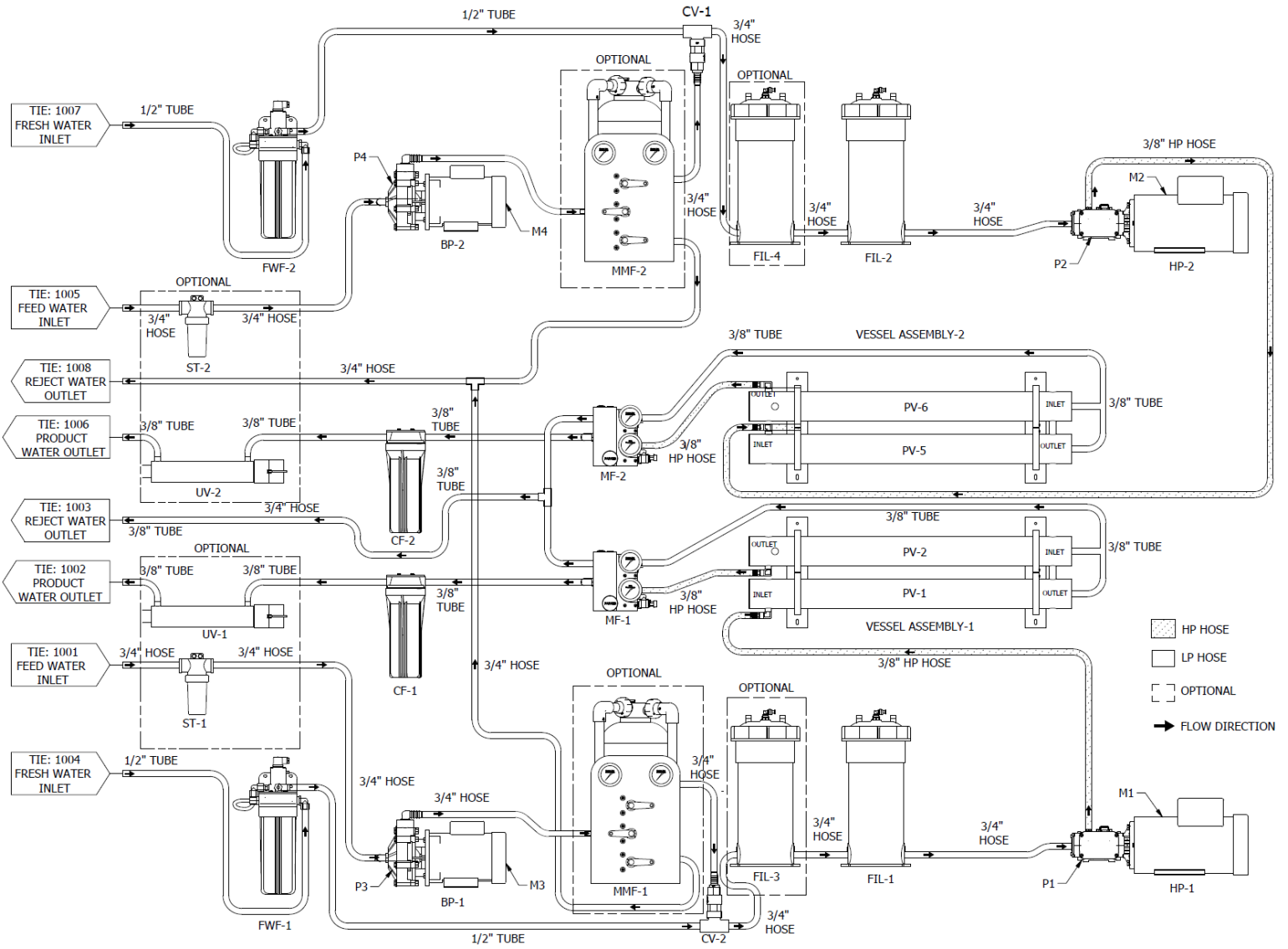

Figure 2.5: Piping and Instrumentation Diagram 2800-3600 GPD (with Optional 20-Micron Prefilter)

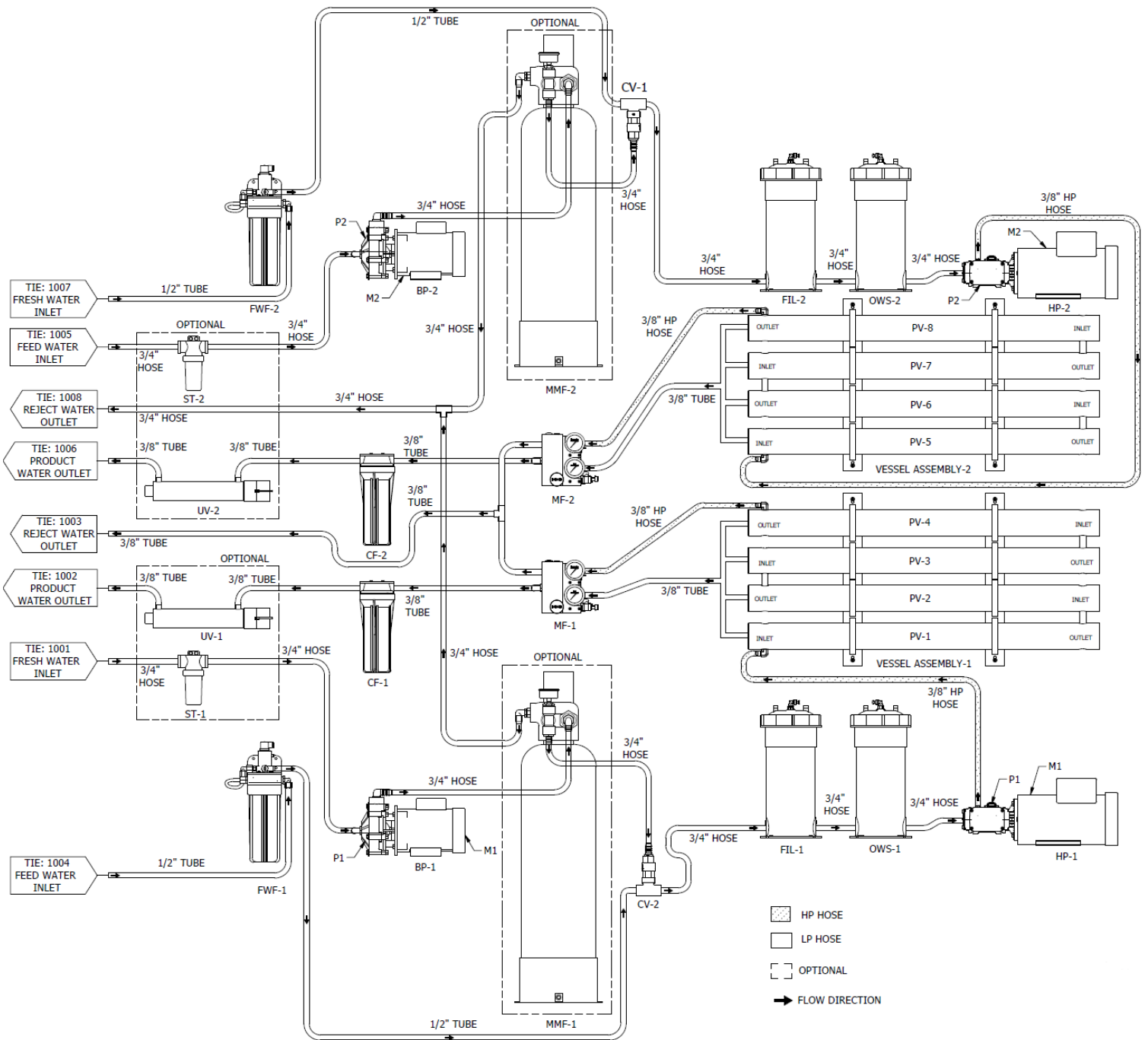

Figure 2.6: Piping and Instrumentation Diagram 4800-6200 GPD

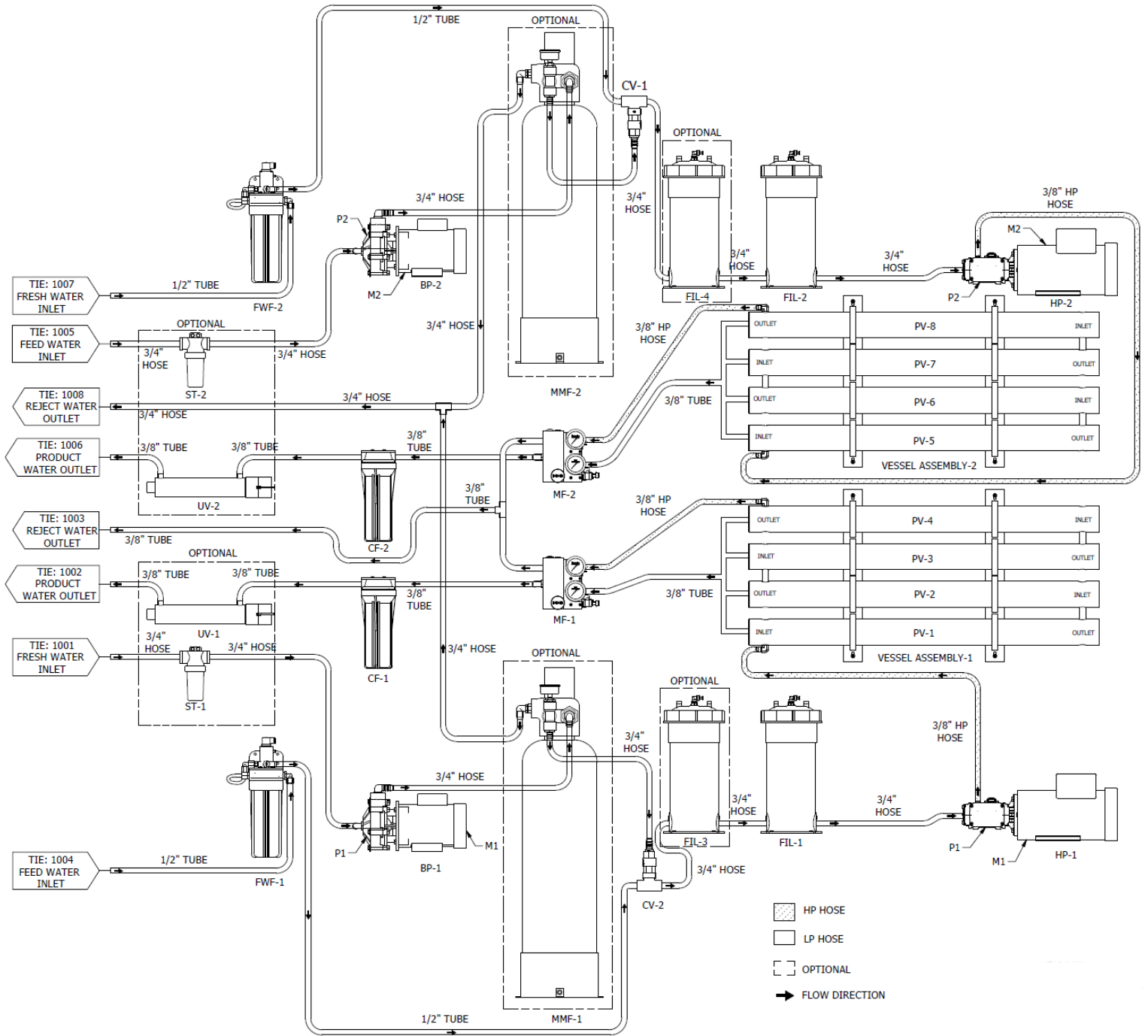
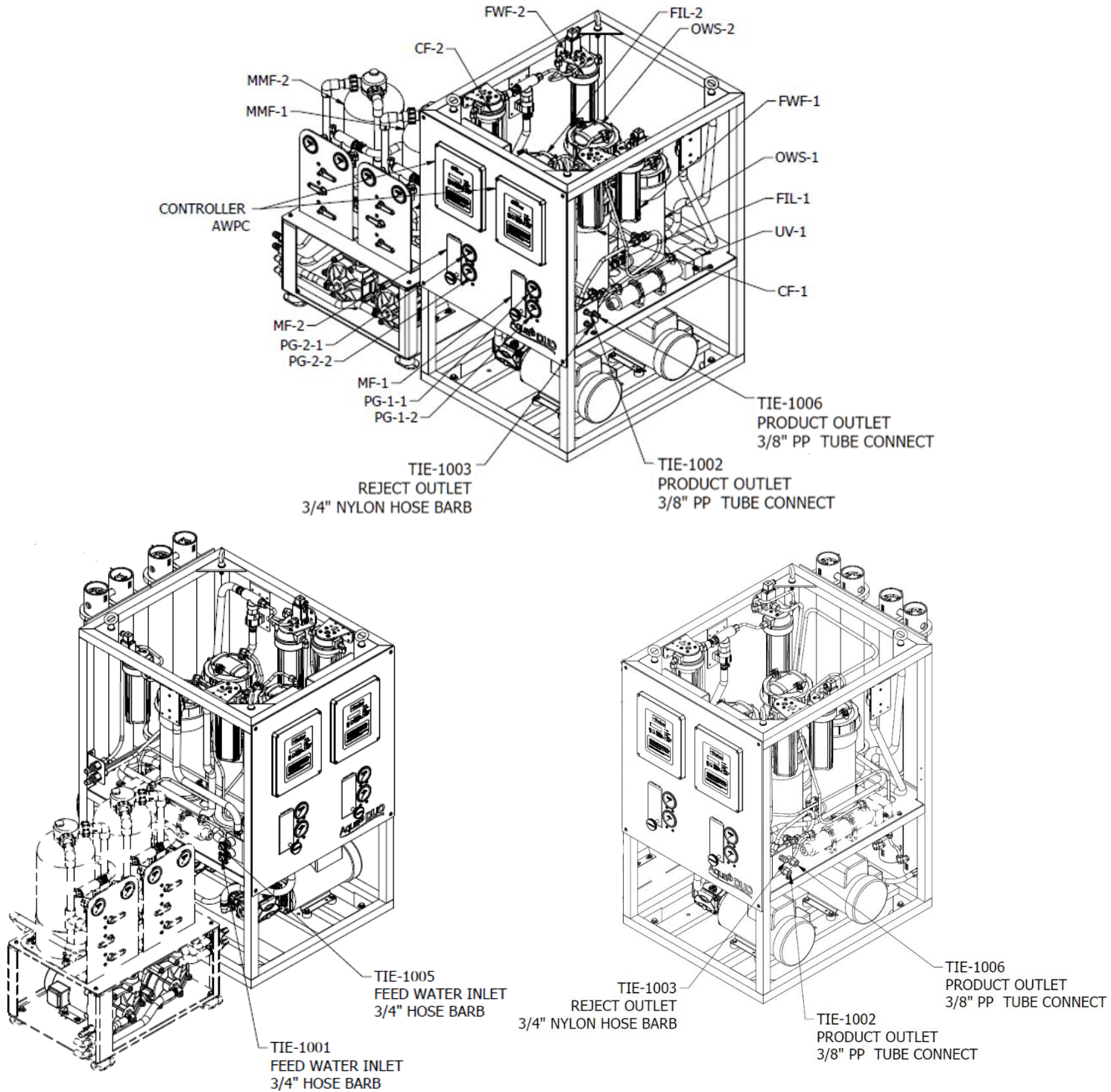
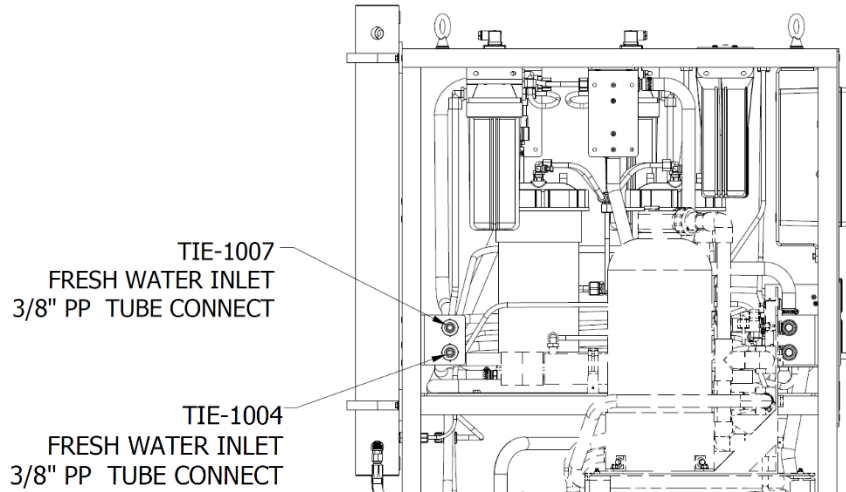

Figure 2.7: Piping and Instrumentation Diagram 4800-6200 GPD (with Optional 20-Micron Prefilter)

2.5 MOUNTING COMPONENTS

Mounting and plumbing components Inlet and discharge interconnecting lines should be constructed of a NON-FERROUS material. Examples of some suitable materials are PVC, copper-nickel, 316 stainless steel pipe or a reinforced non-collapsing hose.





TIE POINT CONNECTION		
TIE	DESCRIPTION	CONNECTION
1001	FEED WATER INLET	3/4" NYLON HOSE BARB
1002	PRODUCT WATER OUTLET	3/8" PP TUBE CONNECT
1003	REJECT OUTLET	3/4" NYLON HOSE BARB
1004	FRESH WATER INLET	3/8" PP TUBE CONNECT
1005	FEED WATER INLET	3/4" NYLON HOSE BARB
1006	PRODUCT WATER OUTLET	3/8" PP TUBE CONNECT
1007	FRESH WATER INLET	3/8" PP TUBE CONNECT

Figure 2.9: Tie Point Connection Callouts

- 1) **Sea Strainer (ST-1 & ST-2) - Optional:** This filter helps protect the RO system by removing large particles and debris coming in from seawater. Parker recommends mounting a sea strainer **BELOW** the vessel's waterline. The strainer can be installed before or after the Feed Water Inlet as long as it is below the waterline.

KIT	PART NUMBER
INSTALLATION KIT 2800-6800 GPD	61012126

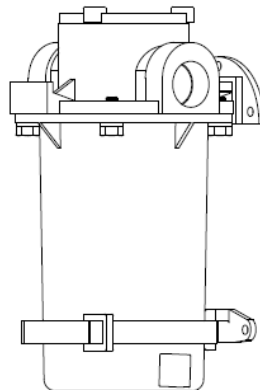

Figure 2.10: Optional Strainer (ST-1 & ST-2) included in Installation KIT

2) **Media Filter (MMF-1 & MMF-2) - Optional:** Parker Recommends installation of the Optional Media filters to remove larger and unwanted particles, thus increasing the system’s lifespan. The location of the Media Filter assembly is installed after the booster pump. The media filter assembly Kit includes the Media filters, the media filter skid/frame, and the plumbing required to plumb with the booster pump. The Kit allows the user to install the booster pumps and the Media filters on the same skid (see Figure below).

KIT	PART NUMBER
MEDIA FILTER ASSYEMBLY KIT 2800-3600 GPD	0151010
MEDIA FILTER ASSYEMBLY KIT 4400-6800 GPD	0151009

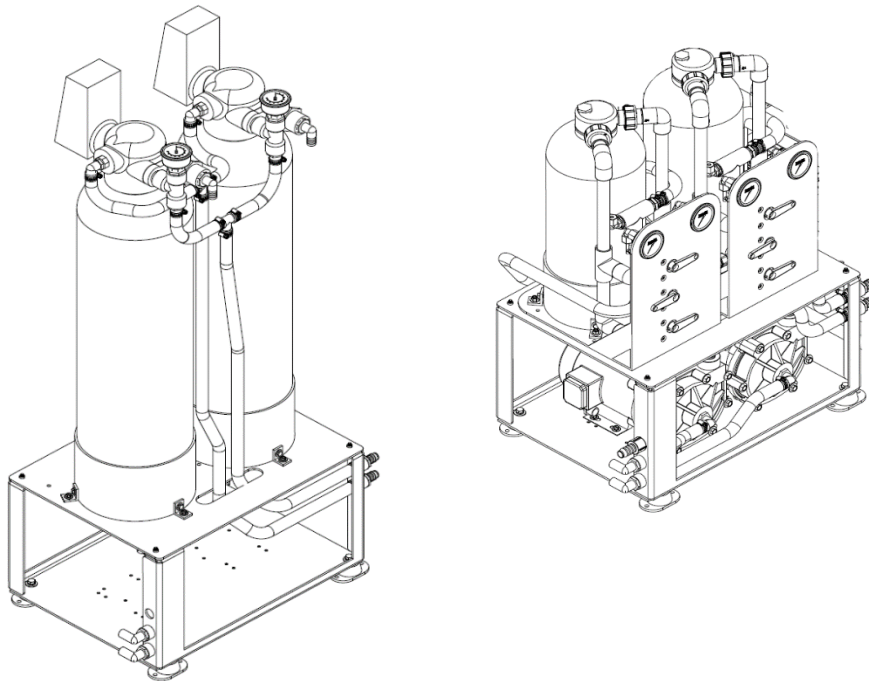

Figure 2.11: Optional Media Filter Assembly (Booster Pumps not included in KIT)

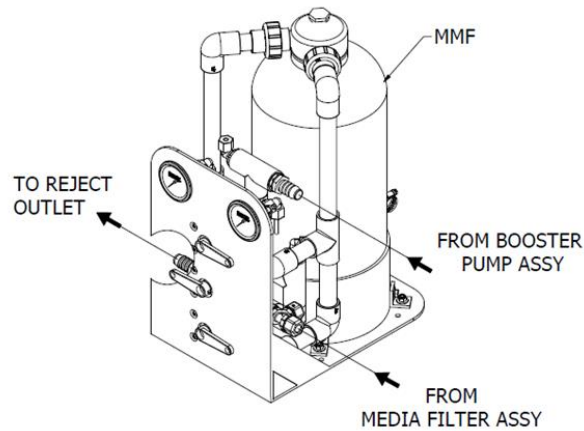

Figure 2.12: Optional Media Filter Assembly (MMF-1 & MMF-2)

3) **Aqua Duo Frame:** The frame holds all the major components of unit A & B .

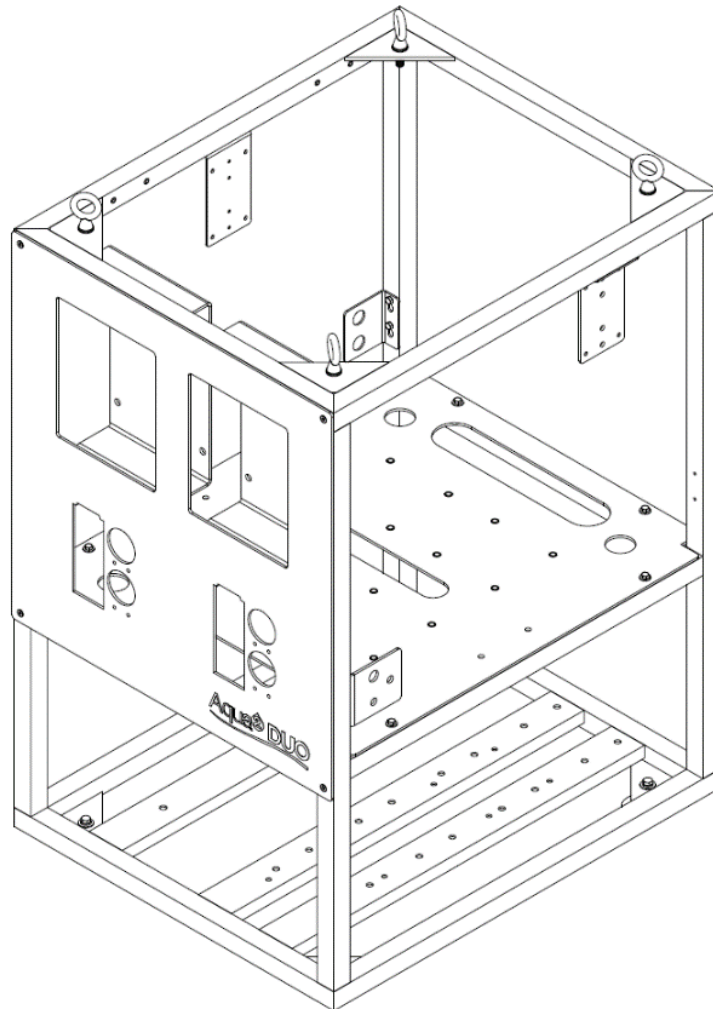

Figure 2.13: Main frame Assembly

4) **Automatic Fresh Water Flush (FWF-1 & FWF-2) :** This assembly includes a Carbon Filter and an automatic, motor-actuated flapper style Valve that automatically flushes the System with Fresh Water. This process occurs automatically every time the System shuts down and repeats on a preset frequency (in days). Fresh Water Flushing replaces the sea water in the System with less corrosive fresh water, which also reduces the biological growth and subsequent decay that naturally occurs if the sea water is not flushed from the System with fresh water. The FWF filters on the Aqua DUO have their own special inlet connections (TIE 1004 & 1007) and they are plumbed with the Check Valve Tee assembly (CV-1 & CV-2).

KIT	PART NUMBER
CARBON FILTER ELEMENT FOR FWF-1 & FWF-2	33-0311

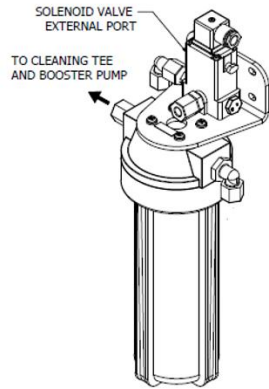

Figure 2.14: Freshwater Flush Filter (FWF-1 & FWF-2)

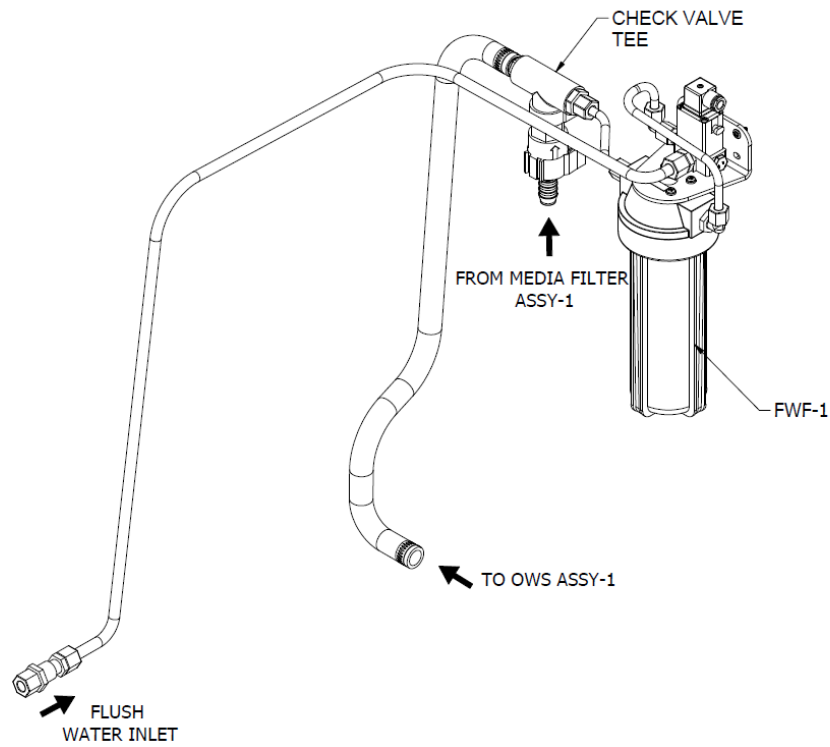

Figure 2.15: Freshwater Flush & Check Valve Assemblies

- Fresh Water Flush 2-way Solenoid Valve : Automatically actuates at System shut down (and at a preset frequency, in days) to flush the system with Fresh Water.

- Fresh Water Flush Check Valve (CV-1 & CV-2) : Prevents Feed Water from entering the freshwater line.

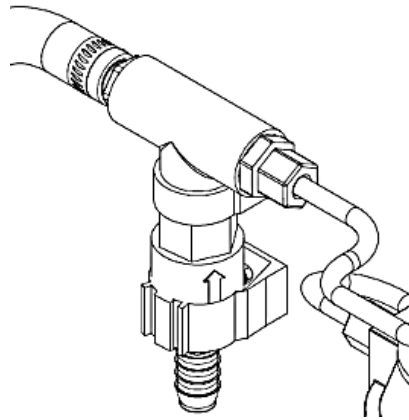

Figure 2.16: Check Valve (CV-1 & CV-2) Assembly

- Fresh Water Flush Carbon Filter : Removes chlorine (if present) in the Fresh Water, prior to flowing through the RO Membrane Element.
- Rinse Clean Valves (optional) : Mounted separately on singular individual plates or together on a double plate. The Rinse Clean Inlet Valve (used in conjunction with the Rinse Clean Outlet Valve) simplifies the storage and cleaning procedures by allowing the Operator to turn a valve, rather than disconnect a hose. Also used for manual Fresh Water Flush if the Automatic Fresh Water Flush System is not installed. Note that the Rinse Clean Valves are available on single or double valve mounting plates

5) **Booster Pump (Two Included with System)**: Provides Inlet water pressure for system. Mount boost pump below the water line. Booster Pumps can also be mounted on Media Filter Assembly KIT.

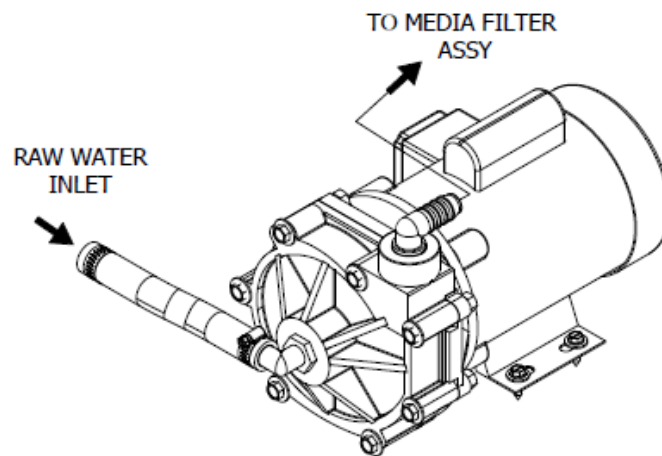

Figure 2.17: Boost Pump Assembly (BP-1 & BP-2)

SINGLE/THREE PHASE	PERMEATE GPD	VOLTAGE	BOOSTER PUMP PART NUMBER
SINGLE	2800 - 3600 GPD	110/230 AC/50/60 Hz	B016080026
THREE PHASE	2800 - 3600 GPD	208/460 AC/50/60 Hz	B016080027
SINGLE	4400 - 6200 GPD	115/230 AC/50/60 Hz	B016600005
THREE PHASE	4400 - 6200 GPD	380/460 AC/50/60 Hz	B016510001

Table 2.2: Booster Pump Spec

- 6) **Oil and Water Separator Filter (included):** This filter separates any unwanted particles, oils, and air bubbles before prefiltration. The OWS Filter Housing 32.5 sqft assembly is located on the skid to allow the operator to conveniently change filters. An optional upgrade to a 20-micron filter is available for enhanced prefiltration.

KIT	PART NUMBER
OWS Filter Element	08020723KD
20-Micron Filter Element	0801133257

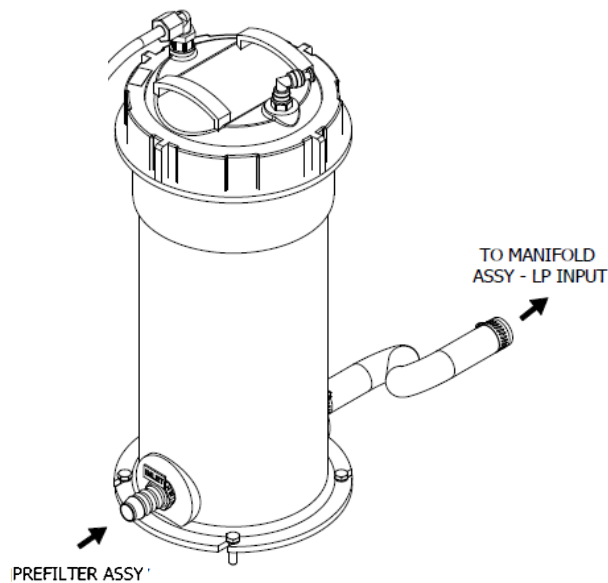

Figure 2.18: Oil & Water Separator (OWS-1 & OWS-2) Assembly

- 7) **5- Micron Filter (included):** Prefiltration that removes particles larger than 5-microns. The 5-micron prefilter assembly is located conveniently on the skid.

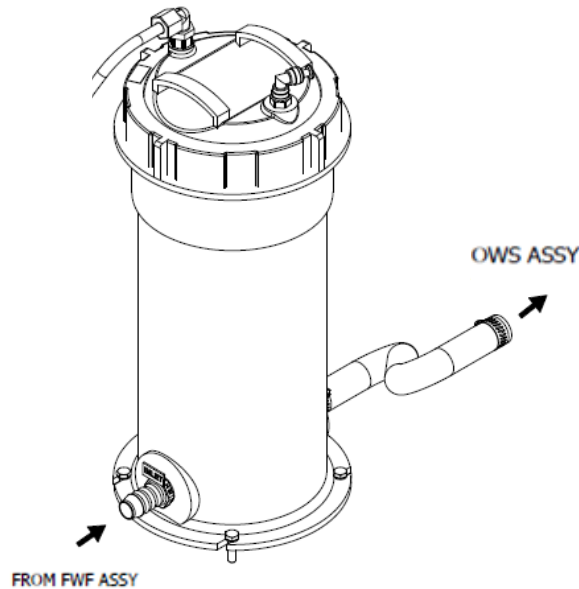

Figure 2.19: 5-Micron Prefilter Assembly

⊘ Caution: Do not use third party prefilter elements; use only PARKER Prefilter Elements. Third party prefilter elements on the market do not properly fit, the seams fall apart, they will allow by-pass, and will allow the R.O. Membrane Element to foul prematurely. Use of third party prefilter elements will void any and all Parker warranty to the High-Pressure Pump and the RO Membrane Element.

The Prefilter Pleated Cartridge Element may be cleaned with water spray once or twice. After cleaning the expected life will be reduced by half. Attempts to clean the element more than twice will result in a very short life and will damage the element rendering it useless. Change the element after the first or second cleaning. Clean or replace the element when plugged to the extent that the Low-Pressure Gauge at the control panel reads 10 to 6 psi. At slightly below 6 PSI, the Low-Pressure Switch shuts the system off.

🔍 Important: Do not use “string wound” or “fiber” prefilter elements. These types of elements are designed for the Photographic Film Developing industry. When used in sea water, they will plug up rapidly in 1/10th or less the time causing frequent shut down of the system and very frequent changing which will also lead to very high cost of maintenance. Use of String Wound or Fiber type elements will only lead to user frustration and very high maintenance costs. Use of third party prefilter elements will void any and all Sea Recovery warranty to the High-Pressure Pump and the RO Membrane Element.

KIT	PART NUMBER
5-Micron filter Element	0801063357

- 8) **Charcoal Filter (Included)** : Helps Removes organic compounds and orders (if present) from Product Water. The water flows directly from the product output at the Manifold to the filter.

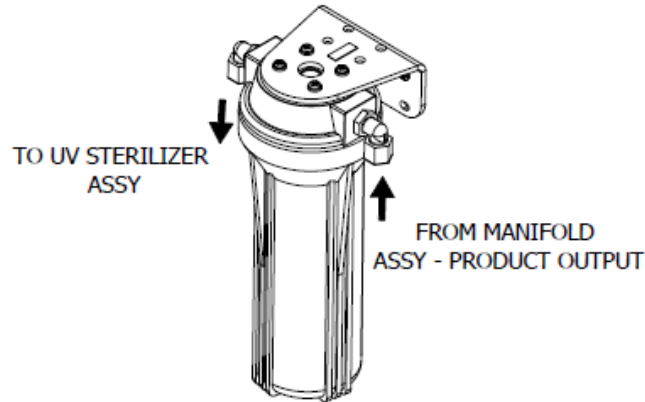

Figure 2.20 : Charcoal Filter (CF1 & CF2) assembly

The charcoal filter should be replaced every 3 to 4 months. If a sulfurous (rotten egg) odor is found in the product water or while changing the filter, increase the replacement frequency.

KIT	PART NUMBER
Charcoal filter Element	0803004773

- 9) **Ultraviolet Sterilizer (Optional)**: The UV Sterilizer is a device that kills bacteria and other microbes using UV radiation. Plumbing of this device should be located after the charcoal filter, conveniently on the skid.

The UV Sterilizer lamp emits a low frequency form of light. This light degrades and loses intensity and the ability to sterilize biological matter over approximately 4,000 hours of use. Therefore, the lamp may remain lit, but requires replacement every 4000-8000 hour.

⊘ Caution: System power must be turned off before beginning sterilizer maintenance. UV light is harmful to eyes and skin.

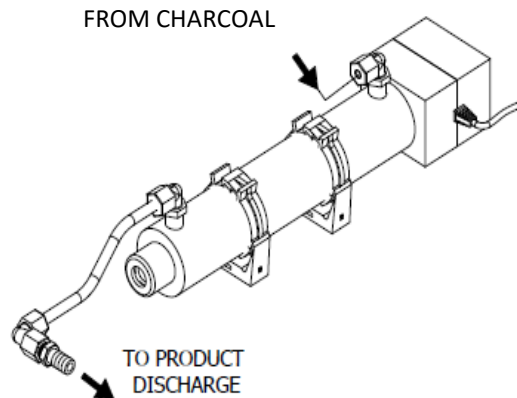

Figure 2.21: Ultraviolet Sterilizer

10) **High Pressure Pump and Motor Assembly (Included):** The High-Pressure Pump Assembly provides high pressure to the vessel membranes to produce potable water.

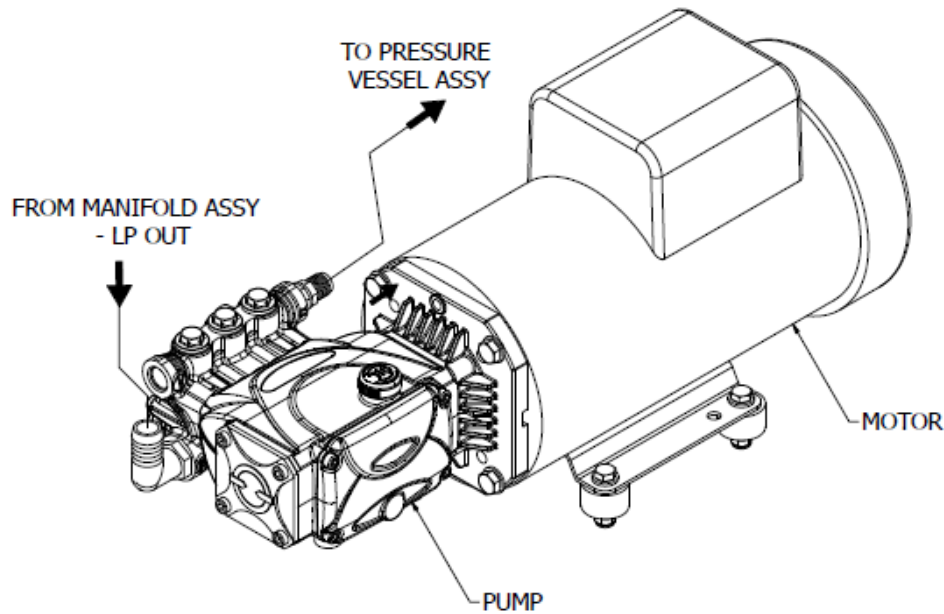

Figure 2.22: High Pressure Pump and Motor Assembly

High Pressure Pumps:

SINGLE/THREE PHASE	PERMEATE GPD	VOLTAGE	HIGH PRESSURE PUMP PART NUMBER	SINGLE/THREE PHASE
SINGLE	2800 - 3600 GPD	110/230 AC/50/60 Hz	B016080026	SINGLE
THREE PHASE	2800 - 3600 GPD	208/460 AC/50/60 Hz	B016080027	THREE PHASE
SINGLE	4400 - 6200 GPD	115/230 AC/50/60 Hz	B016600005	SINGLE
THREE PHASE	4400 - 6200 GPD	380/460 AC/50/60 Hz	B016510001	THREE PHASE
SINGLE	2800 - 3600 GPD	110/230 AC/50/60 Hz	B016080026	SINGLE

Table 2.3: High Pressure Pump and Motor Assembly

11) **Manifold Assembly:** The manifold connects all the necessary plumbing and displays the instrumentation for the system.

The low-pressure and high-pressure transducers for the systems are directly connected to the manifold, they make sure the system operate at safe conditions and are needed for the controller to operate.

The Flowmeter valve controls the product flow of the system, this also directly affects the pressure. The flowmeter valve is used to incrementally adjust the unit pressure during the initial setup or maintenance of the system.

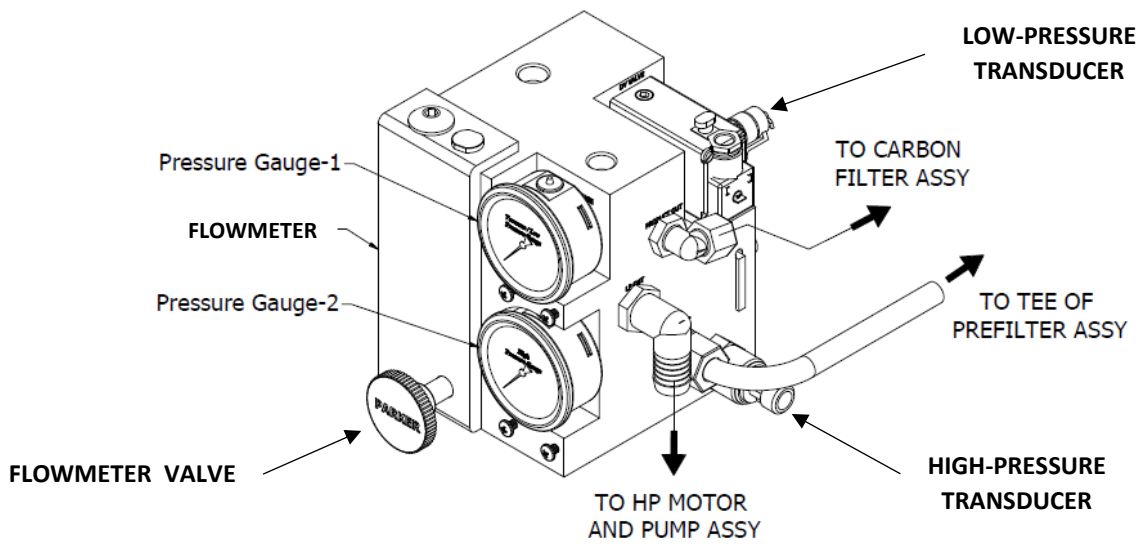

Figure 2.23: Manifold Assembly

12) **Vessel assembly:** Located at the back of the frame. The vessel assembly allows the membrane filters to be pressurized to create potable water. The vessel assembly can be relocated from the frame and mounted separately. Keep in mind, longer High-pressure hoses will be needed for remote assembly of the vessels. Contact your local distributor to purchase additional length High Pressure hose.

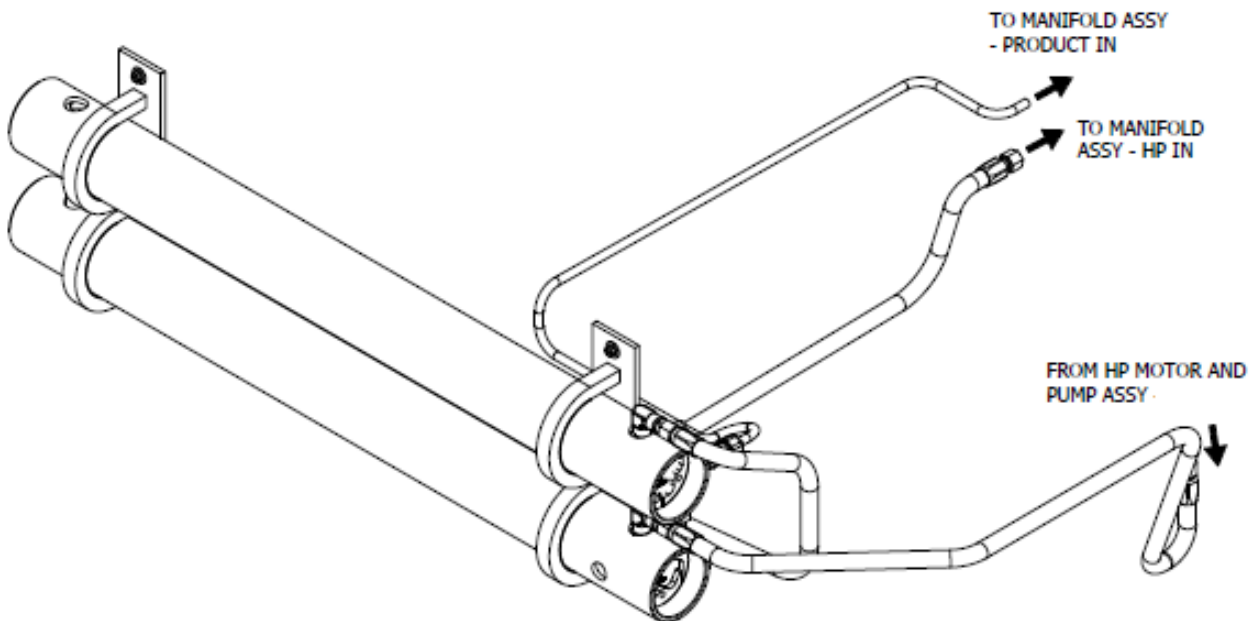

Figure 2.24: Two Vessel Assembly

- 13) **Power Panel Assembly:** Provides necessary voltage and power to the control panel and motors of a unit. The power panel assembly is located on the side of the frame. It is only apparent on higher capacity systems (4400-6800 GPD). A high-capacity Aqua Duo system contains two separate Power panel assemblies for each unit (A & B).



Figure 2.25: Power Panel Position

- 14) **Emergency-STOP Button:** Located at the side of the frame, the E-STOP is an emergency button that allows the user to shut down both units of the Aqua Duo system at any time.

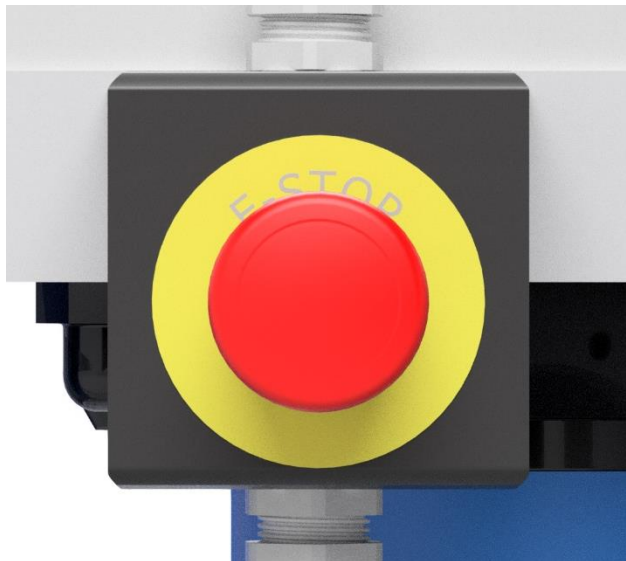

Figure 2.26: Emergency Stop Button

2.6 ELECTRICAL CONNECTIONS

CAUTION

DISCONNECT ELECTRICAL POWER TO THE RO UNIT PRIOR TO CONNECTING OR SERVICING TO THE RO UNIT. FAILURE TO DO SO MAY RESULT IN SERIOUS INJURY OR DEATH TO PERSONS HANDLING THE UNIT.

Strictly observe all applicable electrical codes and regulations governing the installation and wiring of electrical equipment. Typical codes specify the type and size of conduit, wire diameter and class of wire insulation depending upon the amperage and environment. The power supply should always be of a greater service rating than the requirements of the RO unit. Never connect the RO unit to a line that services another electrical device, the RO unit should have its own breaker.

THE RO SYSTEM SHOULD HAVE ITS OWN INDEPENDENT POWER SUPPLY.

Note

The power supply should always be of greater service rating than the requirements of the RO unit. This will assure proper voltage even if power supply voltage is slightly less than required.

Note

110 VAC or 220VAC, single phase, 60/50 hertz units need a three-wire supply, black, white, and green for hot, neutral, and ground, respectively.

240 or 480 VAC, 3 phase, 60/50 hertz units need a four-wire supply, black, red, blue, and green for L1, L2, L3, and ground respectively - bring a separate neutral from the generator if necessary.

Connect power to the main terminal block in the power panel enclosure following the above wire colors.

1. Before connecting electrical power to the water maker. Select the circuit breaker size of at least 50% more than the operating amps shown on the serial number tag.
2. Verify all power switches and power sources are in the OFF position.
3. AC POWERED 110V/220V: Connect RO unit motor to vessel circuit breaker. Parker recommends use of an amp fuse or circuit breaker.

2.7 PLUMBING CONNECTIONS

⊘ **Caution:** Always allow slack in water lines. Allow the line to enter or leave from the fitting in a straight manner for several inches to ensure proper connection, to relieve stress to the fitting and tube or hose, and to allow ease of detachment and re-attachment during maintenance or repair. If water lines are pulled tight (causing them to bend at the fitting), they will leak, take in air, fail prematurely, and/or break the attached fitting.

Connect all inlet feed lines with the supplied Inlet Suction Hose:

Outlet of	To	Inlet of
Sea Cock Valve	➔	Sea Strainer (Optional)
Sea Strainer (Optional)	➔	Inlet 3-Way Clean/Rinse Valve (Optional)
Inlet 3-Way Clean/Rinse Valve (Optional)	➔	Rinse/Clean bucket or container
Inlet 3-Way Clean/Rinse Valve (Optional)	➔	Booster Pump
Booster Pump	➔	Media Filter (Optional)
Media Filter (Optional)	➔	Fresh Water Flush & Check Valve Inlets
Fresh Water Flush & Check Valve Inlets (TIE	➔	TIE 1001 & TIE 1005

Tube Fitting Connections Assembly

1. Cut tube end square and clean.
2. Loosen nut on fitting three turns.
3. Insert tube into fitting until it bottoms. Loosen nut completely and remove tube with attached parts from body. Check to ensure that the O-Ring is seated onto the tube under the spacer (and not pinched into the body). Insert tube with attached parts into the body and tighten nut finger tight.

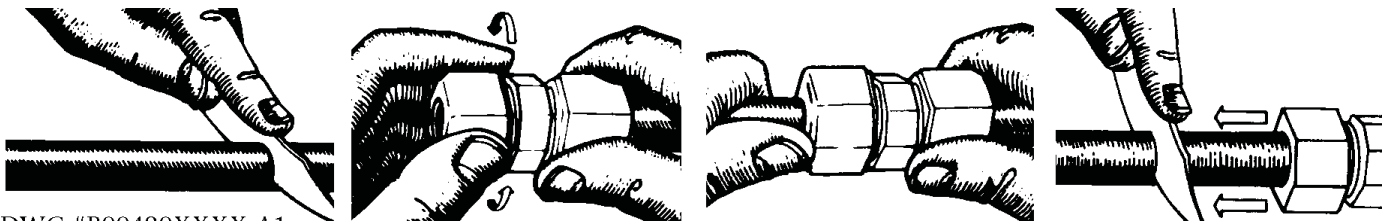

Figure 2.27: Tubing Assembly Instructions

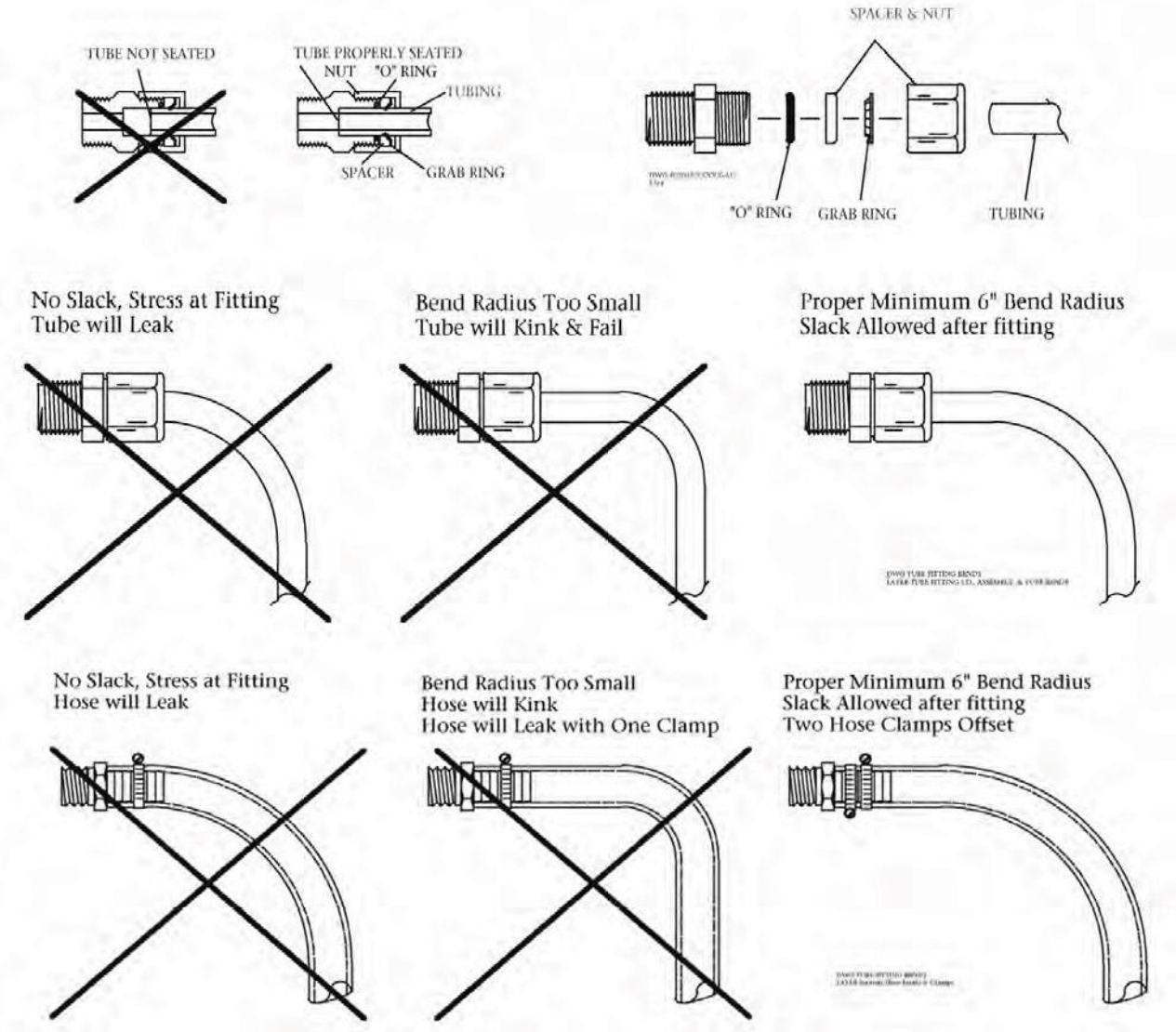

Figure 2.28: Hose & Tube Connection Instructions

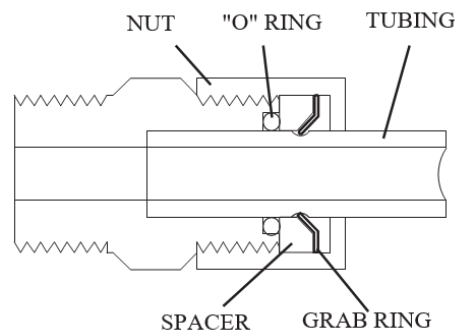

Figure 2.29: Tubing Fitting Internals

4. Connect Brine Discharge line with the supplied Brine Discharge tubing:

Outlet of	to	Inlet of
System Brine Discharge - TIE 1003	➔	Thru Hull Discharge fitting

5. Connect Product Water line with the supplied nylon tubing:

Outlet of	to	Inlet of
Potable Product Water from System – TIE 1002 & 1006	➔	Potable Water Storage Tank

Note

Refer to Piping and Instrumentation Diagram for more details on plumbing.

Component Mounting Instructions

The mounting surfaces must be flat in order to avoid warping of brackets and frames. Use appropriate shims on uneven surfaces to ensure that mounting of the system components does not cause bending or warping.

1. The Optional Sea Strainer is mounted below water level between the Inlet Sea Cock Valve and Booster Pump. Allow at least 4 inches (10 cm) of clearance below the bowl to access the mesh screen for cleaning or replacement.
2. The Fresh Water Flush Filters Canister are mounted to the skid of the system. Allow at least 4 inches (10 cm) of clearance below the bowl for element replacement. Mount the Booster Pumps near the system.
3. The Booster Pump is mounted to a flat surface using the 4 supplied #10 x 1 1/4" long Type "A" screws. The Booster Pump is mounted below water level to assist priming, and in an accessible location to allow access for maintenance. Mount Booster Pump close to the Inlet Thru Hull/ Sea Cock Valve and the Sea Strainer (if purchased). If the booster pump is mounted vertically, mount the motor up and pump head down. Do not mount the pump head above the motor else motor damage will occur if the pump or its fittings should develop a leak. The booster pump can also be mounted on the Media filter Skid if purchased.
4. The Pre-filter are mounted to the skid of the system.
5. Ensure the Charcoal Filter are mounted to the skid of the system
6. The system is mounted to a flat surface using four 1/4" x 2" Type "A" screws.
7. Ensure the UV Sterilizer is plumbed directly after the Charcoal Filter if purchased.
8. Attach the supplied tubing from the Brine/Reject Outlet (TIE 1003) to the boat's Overboard Discharge.
9. Attach the supplied tubing from the Product Outlets (TIE 1002 & 1006) to the Product Water Tank, use a TEE connection if necessary.

3.0 THEORY OF OPERATION AND GENERAL DESCRIPTION

3.1 REVERSE OSMOSIS THEORY

Reverse osmosis, like many other practical scientific methods, has been developed from processes first observed in nature. Osmosis is a naturally occurring phenomenon in which a semi-permeable membrane separates a pure and a concentrated solution (a semi-permeable membrane is defined as one that preferentially passes a substance). Every fluid has an inherent potential that is directly related to the type and number of solids in solution. This potential, referred to as osmotic pressure, increases in proportion to relative concentration of a solution. A concentrated solution, therefore, has an osmotic pressure that is higher than that of a pure solution.

In a desalination system, the less concentrated solution will equalize the concentrations of both solutions by migrating across the membrane. When enough pure solution migrates across the membrane such that the inherent potential difference between the solutions is no longer higher than the osmotic pressure of the membrane, the purer solution will stop flowing. If the pressure on the concentrated solution is increased to above the osmotic pressure, fluid flow will be reversed. This condition, called Reverse Osmosis, can be established by artificially pressurizing the more concentrated solution using a high-pressure pump. In this type of system, the concentrated solution (normally referred to as feedwater) will become more concentrated as pure water flows out of the solution and across the membrane to the permeate side. Discounting the effects of feedwater temperature and salinity, the operating pressure normally required to produce significant amounts of pure water is at least twice the osmotic pressure of the membrane being used.

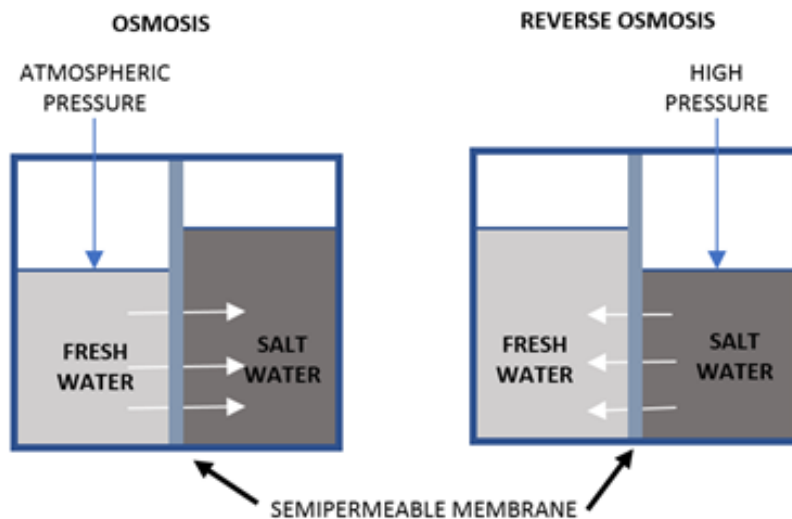

Figure 3.1: Simple (Reverse) Osmotic System

Seawater contains many kinds of solids dissolved in solution. The most prevalent is common table salt (sodium chloride). Other minerals that may be present in solution are substances that usually contain various compounds of calcium and sulfate. The sum of all of the solids dissolved in a particular sample of water is referred to as *Total Dissolved Solids* or TDS. Seawater normally averages 32,000 to

35,000 ppm (parts per million) TDS, although variations of 5000 ppm are common in various parts of the world. The fundamental goal any desalination process is a significant reduction in the number of dissolved solids in water.

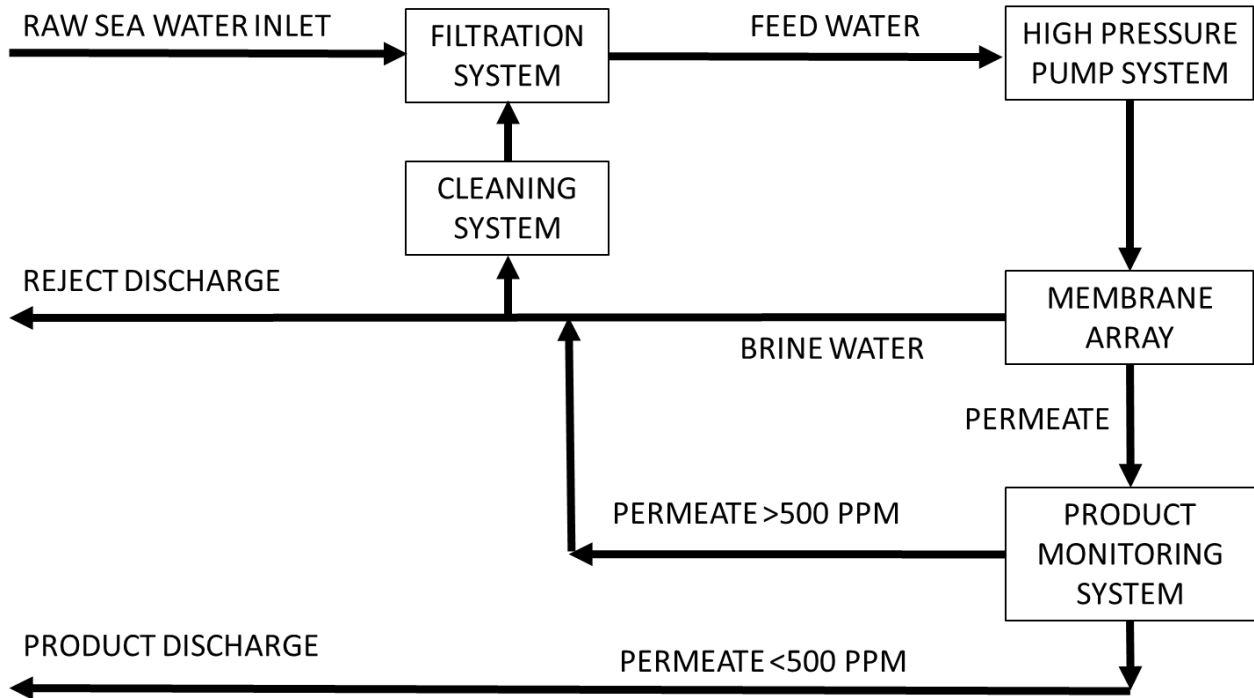

Figure 3.2: Simplified Schematic of a RO System

It should be noted that no system can remove all the dissolved solids from seawater. The system is designed to reject approximately 99% of the TDS or, in other words, to allow 1% of the 35,000 ppm TDS in the seawater to pass into the product water. This yields water of less than 500 ppm, the recommended TDS for drinking water. A system such as this is said to have a salt passage percentage of 1% or a salt rejection of 99%.

3.2 PRODUCT WATER QUALITY STANDARDS

This RO unit will produce permeate (product water) with a quality of < 500 ppm TDS and in accordance with World Health Organization (WHO) standards for drinking water. General specifications for acceptable drinking water quality are as follows:

Constituent Ion/Molecule	Maximum Limits (ppm)
Nitrate	10
Fluorine	.1
Sulfate	100

Constituent Ion/Molecule	Maximum Limits (ppm)
Magnesium	30
Calcium	75
Calcium Carbonate	100
Iron	.1
Manganese	.05
Total Dissolved Solids	500
Turbidity	5
Oil	.1
Detergents (anionic)	.2
Phenols	.001
Bacteria - E Coli (per 100 ml)	0

Table 3.0 - Drinking Water Standards

3.3 FACTORS AFFECTING PERMEATE PRODUCTION

VARIATIONS IN TEMPERATURE, PRESSURE AND SALINITY: The following table illustrates how the quality and quantity of permeate produced by the RO system is affected by changes in temperature, salinity, and pressure:

With constant....	And increasing....	Permeate	
		TDS	Capacity
Salinity and Pressure	Temperature	Increases	Increases
Temperature and Pressure	Salinity	Increases	Decreases
Temperature and Salinity	Pressure	Decreases	Increases

Table 3.1: Factors Affecting Permeate Quality

Note

If feedwater salt concentration decreases, the product water flow rate should not be allowed to increase more than 20% above rated flow. Membrane Reject pressure will need to be lowered to maintain rated flow in brackish water or freshwater applications.

The RO system can be adjusted to maintain a constant permeate output when feedwater salinity is below nominal (near river mouths or in estuaries). The operator can do this by controlling system pressure manually via the back-pressure regulator valve, located in the system brine piping. For long pump life and low membrane fouling, Parker recommends that 9 psi is not exceeded except in situations of extreme low temperature feed water.

CAUTION

Operating the unit at more than 120% of rated capacity in low salinity water can damage the membranes and will void the RO unit warranty.

3.4 TEMPERATURE CORRECTION FACTOR

As previously described, the output capacity of any RO unit is highly dependent on feedwater temperature. To quantify this relationship, theoretical data has been utilized to develop Temperature Correction Factors (TCF) to compensate measured flowrate to calculated flowrate at 25°C/77°F. This allows the operator to establish the baseline flow for a given temperature, allowing more accurate troubleshooting. The procedure for calculating the temperature compensated flow is as follows:

°C	Factor	°C	Factor	°F	Factor	°F	Factor
1	3.64	26	0.97	34	3.47	84	0.88
2	3.23	26	0.94	36	3.18	86	0.82
3	3.03	28	0.91	38	3.18	88	0.79
4	2.78	29	0.88	40	2.68	90	0.79
5	2.58	30	0.85	42	2.47	92	0.77
6	2.38	31	0.83	44	2.29	94	0.75
7	2.22	32	0.80	46	2.14	96	0.73
8	2.11	33	0.77	48	2.01	98	0.70
9	2.00	34	0.75	50	1.88	100	0.68
10	1.89	35	0.73	52	1.77	102	0.65
11	1.78	36	0.71	54	1.68	104	0.63
12	1.68	37	0.69	56	1.59	106	0.61
13	1.61	38	0.67	58	1.51	108	0.59
14	1.54	39	0.65	60	1.44	110	0.57
15	1.47	40	0.63	62	1.36	112	0.55
16	1.39	41	0.61	64	1.30	114	0.53
17	1.34	42	0.60	66	1.24	116	0.51
18	1.29	43	0.58	68	1.17	118	0.49
19	1.24	44	0.56	70	1.12	120	0.47
20	1.19	45	0.54	72	1.08	122	0.45
21	1.15	46	0.53	74	1.05		
22	1.11	47	0.51	76	1.02		
23	1.08	48	0.49	78	1.00		
24	1.04	49	0.47	80	0.93		
25	1.00	50	0.46	82	0.90		

Table 3.2: Temperature Correction Factors (TCF)

- 1) Measure raw water temperature and determine the corresponding correction factor from Table 4.2 based on the measured temperature.
- 2) Note the actual product flow rate at the *Product Flow* meter or digital product readout. Multiply the actual product flow meter flow rate by the correction factor from Table 4.2 to give theoretical temperature compensated flow under standard conditions (25°C).

Example:

Raw Water Temperature:	15°C
TCF (Temperature Correction Factor):	1.47
Actual Product Flow:	113.5 (gph)
Calculation:	$113.5 \times 1.47 = 167$ (gph)

Temperature Corrected

Flow: 167 (gph)

3.5 CONTROLS AND INSTRUMENTATION

The following table provides a brief description of each individual component along with an explanation of its function. It is intended as a supplement to the more detailed information contained in the System/Equipment Drawings and Diagrams.

3.6 RO FILTRATION SYSTEM DESCRIPTION

The raw seawater supplied flows to the booster pump where the pressure is increased to flow through the filtration section of the system.

The fresh water passes through the Freshwater Flush Filter, which is designed to reduce chlorine of the fresh water entering the unit when flushing. The filter housing consists of one carbon filter cartridge (see section 1.4). The automatic valve for the freshwater flush filter, located on the top of the filter housing, diverges water coming to the unit. The raw seawater is bypassed through the valve to skip the freshwater flush filter and enter the unit.

Next the raw sea water passes through the 5-micron pre-filter, which is designed to reduce raw water turbidity to a nominal 5-microns in diameter. The micron filter consists of one 5-micron filter cartridge. The inlet and discharge pressure from the filter housing are monitored by the pressure gage & transducer, which allows the operator to determine when the filter element requires replacement.

3.7 REVERSE OSMOSIS SYSTEM

The clean and filtered raw water (now referred to as feedwater) is supplied to the inlet of the high-pressure pump. This pump raises feedwater pressure to 56-65 BAR (800 - 950 psi), the nominal

pressure required for optimal system recovery. The pressurized feedwater then flows directly into the membrane pressure vessels (array). The membrane array is an arrangement of fiberglass pressure vessels each containing RO membrane elements.

The pressurized feedwater flows along the membrane elements where reverse osmosis takes place. The feedwater flow is divided into two streams - the high purity product stream (referred to as the *product*) and the increasingly concentrated reject stream (referred to as the *reject*).

3.8 PRODUCT MONITORING SYSTEM

The product water stream flows past a conductivity sensor, which provides a signal to the water quality monitor. Depending on the concentration of total of dissolved solids (TDS) in the permeate stream, the following occurs:

If permeate TDS is > 500 ppm, indicating poor quality water, a signal is sent to divert the product water to the reject line.

If permeate TDS is < 500 ppm, indicating good quality water, a signal is sent to divert the product water to the product line.

In addition, there is a product water flow meter and transducer to allow the operator to determine how much water is being made.

3.9 FRESH WATER FLUSH SYSTEM

This RO unit includes a freshwater flush system which provides a means for removing the sea water from the RO system. By using the freshwater flush cartridge housing with carbon filter installed and the automatic feed inlet valve the system will automatically freshwater flush upon system shutdown. Complete information of the freshwater flush procedures can be found in Section 6.4.

3.10 HUMAN-MACHINE INTERFACE (HMI)

The HMI/Controller monitors and displays system health and conditions like permeate salinity, temperature, pressure, and accumulated unit operating hours. It also provides operational mode control of the system.

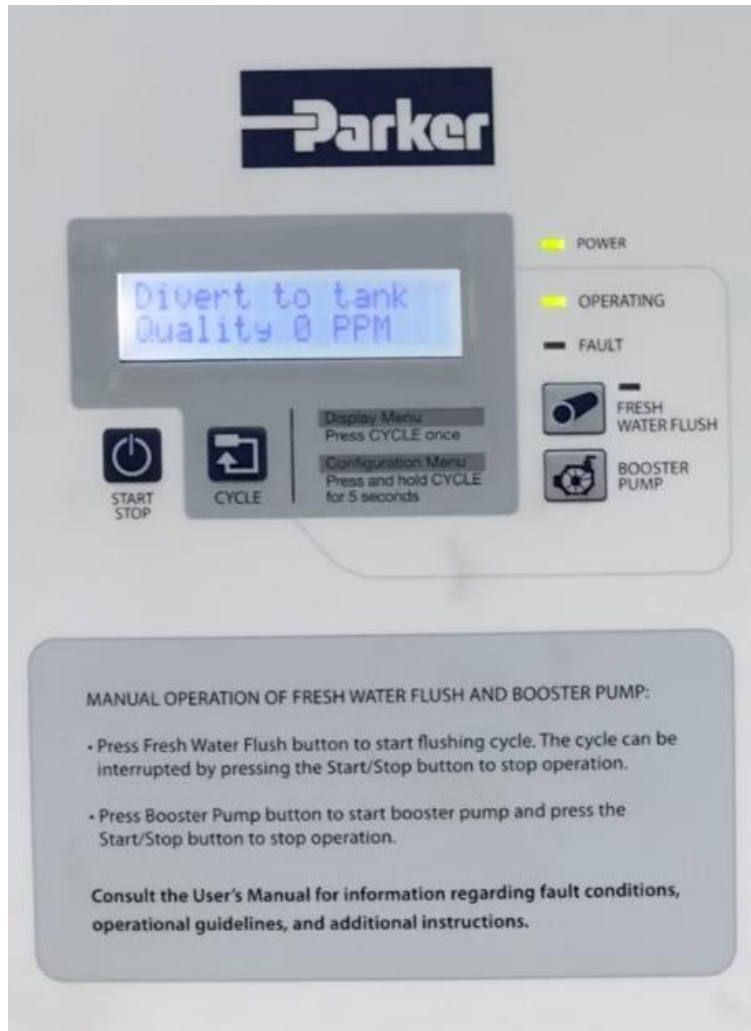

Figure 3.3 – Human-Machine Interface (HMI)/Controller

4.0 COMMISSIONING

4.1 COMMISSIONING CHECKLIST

1. Inspect - Make sure all external plumbing connections are made per the P&ID diagram. Make sure all electrical connections to all external devices are connected properly per the electrical schematics.
2. Install micron filters.
3. Install Fresh Water Flushing Filter.
4. Install Membranes.
5. Valve Alignment
6. Ensure that the installation has been properly performed.
7. Check the RO Membrane Element as described below.
8. Check the oil level in the HP pump. Be sure it is at the proper level.

NOTE

Some systems are shipped WITHOUT the RO Membrane Element. This is to accommodate, for example, boat builders who install the system well in advance of commissioning the boat and the Parker Hannifin System.

If the RO Membrane Element has been installed, there will be an Element Serial Number tag attached to the RO Membrane/Vessel Assembly. Find this serial number tag to ensure that the RO Membrane Element has been installed.

If the RO Membrane Element Serial Number tag is missing or does not contain a serial number and date, then immediately contact the company that sold the system to you or Parker Hannifin. Provide Parker Hannifin with the system serial number and model number of Aqua Duo System.

CAUTION

DO NOT attempt to operate the system without a RO Membrane Element installed in the system, as extensive damage will result.

9. Ensure that the manual bypass lever located on the side of the 3-Way Product Water Solenoid Diversion Valve is positioned outward (away from the coil body).
10. Check each hose and tube connection to the system to ensure that the installer has properly connected and routed each hose and tube. Ensure that there are no kinks or blockages in any of the hoses or tubes leading to and from the Aqua Duo. Improper routing and any blockage in any line causes damage to the system. *Do not rely on the installer's word; check it yourself.*
11. Make sure that the electrical power source, the boat's circuit breaker, to the system is switched "OFF."
12. Open the front panel of the Main Power Enclosure. Check all electrical and electronic connections for proper wiring and attachment.
13. Ensure that the installer has used the proper-sized power wire and Booster Pump wire.
14. Close the Main Power Enclosure front panel.
15. Open the Sea Cock Valve.
16. Open any auxiliary valve within the incoming feed line, Outgoing Brine Discharge Line and Outgoing Product Water Line.

CAUTION

Caution: Any auxiliary valve in these lines damages the Parker Hannifin System if left closed during starting and/or operation of the system.

17. If the optional Clean Rinse Valves are installed, ensure that they are positioned properly for normal operation.
18. Switch the electrical power source to the "ON" position, the boat's circuit breaker.

19. On three phase systems, perform a Feed pump motor rotational check. Ask an assistant to view the fan chapter of the Feed Water Pump Motor while “jogging” this electric motor.

NOTE

On three phase systems Press the “START/STOP” button; then immediately after the booster pump starts, press the “START/STOP” button. Ensure that the Feed Water Pump Electric Motor is turning in the proper rotation.

23. To start the system, press, the “START/STOP” button. If the system automatically shuts off immediately or after 20 seconds of operation, this may be due to a system fault. Look at the Controller to confirm whether a fault has occurred. If Error ID 2 or 3 (High /Low Pressure Error) appears on the screen, ensure that the system feed line is primed and that there is no air in the feed water line. Then, restart the system. Initial new system commissioning may require priming of the feed water up to the Feed Pump inlet and through the pre-filtration to build sufficient feed water pressure to maintain operation. Refer to the Troubleshooting Section of this manual.
24. Although the system is producing “product water,” the “product water” may not be “potable” for up to 30 minutes. New RO Membrane Elements require operating time to flush storage chemical from the product water channel. Daily operation requires operating time to flush dissolved solids from the product water channel. The operating time required to flush the product water channel is normal for reverse osmosis systems. The salinity of the product water diminishes gradually and is measured by the salinity probe. When the salinity of the product water has diminished to the factory setting, the salinity controller will energize the 3-Way Product Water Diversion Valve. At that instant, product water will be routed to the charcoal filter, and optional UV sterilizer onward to the potable water storage tank.
25. Check for the following:
 - a) Constant feed water flow.
 - b) Consistent system pressures.
 - c) Leaks in the system.
 - d) Unusual noises or other occurrences.
26. Complete the “**NEW SYSTEM INITIAL READINGS**” form at the end of this chapter.
27. Prior to stopping the system, determine if the system will be stored for a period of time or if it will be turned over to the owner and operated regularly. Failure to properly flush and/or store the system will lead to premature fouling or drying out of the RO Membrane Element, which is not covered by the Parker Hannifin Warranty and is the liability of the person commissioning the system.
 - a) If the system will be operated within the next two weeks, no action is necessary. However, if the system will be exposed to freezing temperatures, you must perform winterizing procedures. Freezing temperatures will cause extensive damage if the system is not properly protected.
 - b) If the system will not be operated within the next two weeks, perform a freshwater flush. If the Parker Hannifin Automatic Freshwater Flush is installed, ensure that the potable water storage tank has potable water for the freshwater flush to utilize in rinsing the system. If the system does not include an automatic freshwater flush, then perform a manual freshwater flush.

- c) If the system will not be operated within the next two months or longer, perform a long-term storage operation.
29. The freshwater flush cycle will last for approximately 10 minutes. After the freshwater flush cycle is complete, the freshwater flush lamp will illuminate and intermittently blink in the stand-by mode. Every 7 days, the freshwater flush rinse cycle will repeat automatically.
- If the "START/STOP" button is pressed twice, the automatic freshwater flush cycle will be cancelled, and the freshwater flush lamp will not be illuminated.
30. Close the Inlet Sea Cock Valve. This is a safeguard for vessel installations.
31. If the freshwater flush is installed and activated, do not interrupt power. If the freshwater flush is not installed or is not activated, turn off the electrical power source (circuit breaker) to the system. This eliminates the chance of inadvertently starting the system. If the power source has been turned off, the freshwater flush will not cycle every 7 days.

4.2 Pressure Changes

The system operating pressure (the pressure applied to the RO Membrane Element) varies with the feed water temperature, the feed water salinity, and the condition of the RO Membrane Element. The system design specifications are based on feed water temperature of 77° F / 25° C and a feed water salinity of 35,000 PPM-TDS (parts per million-total dissolved solids). Each RO membrane element can vary +/- 15%, which will cause the final operating pressure to decrease or increase accordingly. However, assuming the "perfect RO Membrane," at this temperature and salinity the system will operate at the standard system pressure listed within the specifications at the beginning of this Owner's Manual.

If the feed water salinity increases or if the feed water temperature decreases, the system operating pressure will increase. Inversely, if the feed water salinity decreases or if the feed water temperature increases, the system operating pressure will decrease. Furthermore, if the RO Membrane Element is new or old and fouled, the system operating pressure must be adjusted to decrease or increase accordingly to overcome the RO Membrane Element condition using the manifold regulator valve located at front of system.

NOTE

Operating amperage and operating pressure will increase if:

1. The feed water temperature is lower than 77° F / 25° C.
2. The feed water salinity is greater than 35,000 PPM TDS (3.5% Total Dissolved Solids).
3. The RO Membrane Element becomes fouled.
4. The RO Membrane Element is new and on the minus 15% side of the specifications.

Operating amperage and operating pressure will decrease if:

1. The feed water temperature is higher than 77° F/ 25° C.
2. The feed water salinity is less than 35,000 PPM TDS (3.5% Total Dissolved Solids).
3. The RO Membrane Element is new and on the plus 15% side of the specifications.

By monitoring feed water salinity, temperature and resulting system operating pressure, it is possible to measure and monitor the fouling of the RO Membrane Element over time and use. As the feed water vane pump becomes worn from normal use, it will lose flow and the ability to build up pressure.

PARKER HANNIFIN AQUA DUO UNIT A INITIAL READINGS

At the time of commissioning the NEW system, record the following information after one hour of continuous proper operation of the system. Retain this form in the Owner's Manual for future reference and troubleshooting. This information is valuable to the servicing technicians in providing technical support to the owner and future operators of the AQUA DUO SYSTEM. Provide this information to service technicians when requesting technical assistance. **KEEP IN MIND THE AQUA DUO HAS TWO OPERATIONAL UNITS IN ONE FRAME:**

Serial Number: _____

Model Number: _____

System GPD _____

Name of Operator: _____

Date: _____

Installer Information: _____

Company: _____

Street Address: _____

City, State: _____

Country, Postal Code: _____

Telephone Number: _____

Name of Installer: _____

System Power: _____ Volts AC, _____ Hz

Feed Water Temperature: _____ Fahrenheit or _____ Celsius

Hour Meter Reading: _____ Hours

PRESSURE GAUGE READINGS:

Inlet Low Pressure Gauge Reading: _____ PSI, _____ Bar, _____ KPa, or _____ Kg/Cm²

RO Membrane/Vessel Assy Outlet High Pressure Gauge Reading:

_____ PSI, _____ Bar, _____ KPa, or _____ Kg/Cm

WATER FLOW METER READINGS:

Product Water Flow Meter: _____ US Gallons Per Hour, or _____ Liters Per Hour

Brine Water Flow Meter: _____ US Gallons Per Hour, or _____ Liters Per Hour

WATER QUALITY:

Feed Water Salinity: _____ ppm or Location of Use: _____ ; **Product Water Salinity:** _____ ppm

Unusual Occurrences or Noises:

PARKER HANNIFIN AQUA DUO UNIT B INITIAL READINGS

At the time of commissioning the NEW system, record the following information after one hour of continuous proper operation of the system. Retain this form in the Owner's Manual for future reference and troubleshooting. This information is valuable to the servicing technicians in providing technical support to the owner and future operators of the AQUA DUO SYSTEM. Provide this information to service technicians when requesting technical assistance. **KEEP IN MIND THE AQUA DUO HAS TWO OPERATIONAL UNITS IN ONE FRAME:**

Serial Number: _____

Model Number: _____

System GPD _____

Name of Operator: _____

Date: _____

Installer Information: _____

Company: _____

Street Address: _____

City, State: _____

Country, Postal Code: _____

Telephone Number: _____

Name of Installer: _____

System Power: _____ Volts AC, _____ Hz

Feed Water Temperature: _____ Fahrenheit or _____ Celsius

Hour Meter Reading: _____ Hours

PRESSURE GAUGE READINGS:

Inlet Low Pressure Gauge Reading: _____ PSI, _____ Bar, _____ KPa, or _____ Kg/Cm²

RO Membrane/Vessel Assy Outlet High Pressure Gauge Reading:

_____ PSI, _____ Bar, _____ KPa, or _____ Kg/Cm

WATER FLOW METER READINGS:

Product Water Flow Meter: _____ US Gallons Per Hour, or _____ Liters Per Hour

Brine Water Flow Meter: _____ US Gallons Per Hour, or _____ Liters Per Hour

WATER QUALITY:

Feed Water Salinity: _____ ppm or Location of Use:

Product Water Salinity: _____ ppm

Unusual Occurrences or Noises:

5.0 OPERATIONS

5.1 System Operation Notes

The freshwater production of the Aqua DUO Desalination System models depends on six factors:

- Feed Water Temperature
- Feed Water Salinity
- Feed Water Flow Rate
- Operating Pressure
- Characteristics of the individual RO Membrane Element
- Condition of the individual RO Membrane Element

Feed water temperature and salinity vary depending upon location of operation. Feed water flow is fixed on the Aqua Duo System at 4.3 gallon per minute (19.5 liters per minute) by design. The only operator adjustment that remains is the operating pressure, which is adjusted at startup by the operator. Two parameters are controlled by this single operator adjustment: Operating Pressure and resulting Product Water Flow.

The Operating Pressure is adjusted upward until the Aqua DUO Desalination System produces the following:

System	One Unit Turned ON (GPH/LPH)	Two Units Turned ON Simultaneously (GPH/LPH)
A455C-2800	58.3/265	116.6/530
A455C-3600	75.0/341	150/682
A455C-4400	91.7/417	183.4/834
A455C-5200	108.3/492	216.6/984
A455C-5800	120.8/549	241.6/1098
A455C-6800	141.7/644	283.4/1288

Table 5.0: System Capacity with one Unit & Two Units in function

⊘ Caution: The maximum Operating Pressure allowed is 950 psi. Do not exceed 950 psi even if the system does not produce the specified amount of product water. The system automatically shuts down if the maximum Operating Pressure exceeds 950 psi. External factors, such as Feed Water Temperature, Feed Water Salinity, or condition of the RO Membrane Element may cause the system to produce less than specified even though the Operating Pressure is at 950 psi.

5.2 Operation Cautions

- Open all valves on the piping or hoses leading to and from the system.
- Check the Oil level in the High-Pressure Pump.
- Check for any abnormalities such as leaks, damaged hoses, wires, etc.

5.3 Startup Procedure

1. Open the Sea Cock Valve fully.
2. Switch the electrical power to the system on at the circuit breaker. The “POWER” lamp on the system TouchPad will illuminate.
3. Ensure that the back-pressure regulator valve is fully open (counterclockwise). This is not required and is commonly skipped on systems equipped with a Remote Control. Performing this step reduces wear and tear on the mechanical and electrical components.
4. Press the “Start” switch. This initiates the automatic start sequence. The automatic start sequence begins with the booster pump starting immediately and the high-pressure pump following after a brief delay.

or

Press the “Booster Pump” switch then press “Start” switch. Pressing the booster pump switch starts just the booster pump. It continues running by itself until the start switch is pressed.

5.4 High/Low Pressure Fault Lamp Explanation

Low Pressure fault: When the inlet pressure to the high-pressure pump falls below 6 psi, the “High/Low Pressure” lamp blinks. If the condition is not corrected, the system shuts down after 20 seconds. The Low-Pressure switch monitors this condition caused by a dirty pre-filter, a closed Inlet Sea Cock Valve, or restriction at the Inlet Thru-Hull fitting or in the inlet feed line.

High Pressure fault: The High-Pressure switch stops the system if pressure exceeds 950 psi.

1. After the cause of the fault condition has been corrected, press “Fault Reset” and repeat the steps in Startup Procedure (Section 5.3).
2. Slowly adjust the backpressure regulator until the system produces the specified product water gallon per hour flow at the Product Flow meter (DO NOT exceed 950 psi).

See “Temperature Effects” and “Salinity Effects” in Chapter 3 for expected pressure settings and production.

Colder Water: At sea water temperatures below 77°F, the Aqua DUO RO Desalination System must operate at a higher pressure to produce the specified amount of fresh water. As water temperature drops, the individual H₂O molecules are less active and higher pressure is required to drive them through the membrane surface. Another result of lower temperature feed water is that the fresh water produced has a lower salt content. Do not operate with feed water below 33°F / 1°C because the product water will freeze and cause mechanical failure and rupture of components within the system.

Warmer Water: At water temperatures above 77°F, the Aqua DUO RO Desalination System operates at a lower pressure to produce the specified amount of fresh water. As water temperature rises, the individual H₂O molecules are more active and pass through the RO Membrane Element with less pressure. Higher temperatures also allow more salt to make its way into the fresh water. Do not operate with feed water that exceeds

122°F / 50°C. High temperatures will cause structural damage to the RO Membrane Element.

3. If any abnormality develops, turn off the unit and troubleshoot the problem.
4. Check for unusual noises or other occurrences.

5.5 Controller Operations

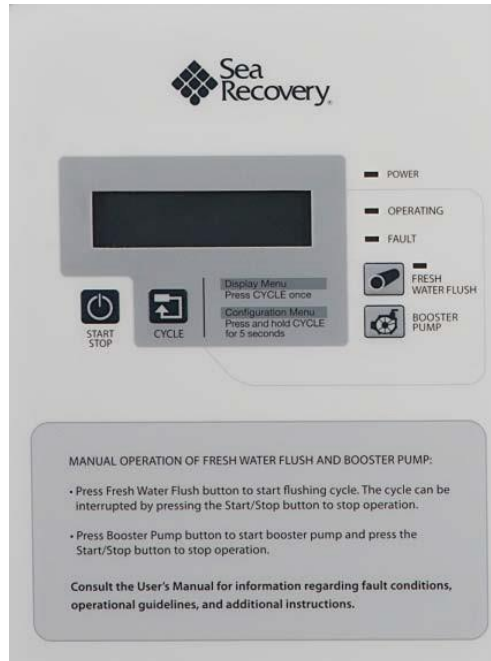

Figure 5.1: Controller Interface

Start/Stop button

1. Powers on and sets the system in its initial state.
2. When the system is producing water and the START/STOP button is pushed, the system stops all pumps and diverts water into the sea.
3. Resets all faults.

Note that this button performs its designated action, regardless of whether or not you are browsing a menu.

Cycle button

This button allows the operator to cycle through the process and configuration parameters.

- Press the CYCLE button once to view to view the Display Menu.
- Press and hold CYCLE for 5 seconds to view the Configuration Menu.

Display Menu

This menu monitors measured values (e.g. pressure, and salinity); system states (e.g.

FWF, running, FWP); and timers. Press the CYCLE button once to view this menu and CYCLE again to scroll through the menu items.

Every time CYCLE is pressed, the next item is shown. If you release, and do not push the CYCLE button for more than 5 seconds, you will return to the main screen.

1. Pre-Filter Press – Inlet pressure in Bar or PSI (pre-filter inlet)
2. HP Inlet Press – Inlet pressure in Bar or PSI (high pressure pump inlet)
3. Membrane Press – Membrane pressure in Bar or PSI
4. Product Flow – Product water flow in l/min or GPM
5. Brine Flow – Brine flow in l/min or GPM
6. Water Quality – Salinity (water status) in ppm
7. Total Hours – High pressure pump/ETD hour meter (counted in seconds but shown in whole hours)
8. Tank Full – Yes or no
9. Tank Empty – Yes or no
10. Booster Relay - Booster pump on or off
11. FWF Relay – Fresh Water Flush on or off
12. HP Relay – High pressure pump on or off
13. DV Relay – Diversion valve on or off
14. UV Relay – Ultraviolet on or off
15. Supply Voltage – volts (used only for diagnostics)
16. Version – software version

Configuration (Change) Menu

This menu shows a list of configuration parameters that can be changed by the operator. Press the CYCLE button and hold for 5 seconds to view this menu and CYCLE again to scroll through the menu items. Every time CYCLE is pressed, the next item is shown. Holding the CYCLE button for more than 5 seconds selects the displayed menu item. Note that this menu does not allow the operator to monitor the state of these configuration parameters. Please use the Configuration (Read) Menu to do so.

1. Unit – units (metric or US)
2. Low Pressure 1 Inst – S1 Lo pressure sensor installed (yes or no)
3. Low Press 2 Inst – S2 Lo pressure sensor installed (yes or no)
4. Prod Flow Inst – Product flow meter installed (yes or no)
5. Brine Flow Inst – Brine flow meter installed (yes or no)
6. Tank Full Inst – Tank level full sensor installed (yes or no)
7. Tank Empty Inst – Tank level empty sensor installed (yes or no)
8. FWF Delay – High pressure pump stop to FWF delay (HH:mm:ss)
9. Time to AutoShut – Auto shutdown after X hours in state FWP (HH:mm:ss)
10. AutoShut Time – Auto shutdown after time (yes or no)
11. AutoShut Tank – Auto shutdown on tank full (yes or no)
12. FWF Duration – FWF duration time (HH:mm:ss)

- 13.FWF Interval – FWF interval time (HH:mm:ss)
- 14.PassiveUVoff – Time from leaving freshwater production to turning UV off (HH:mm:ss)
- 15.UV off delay – Time from UV on to diversion valve to tank (HH:mm:ss)
- 16.AutoStart Tank – Autostart on tank empty (yes or no)
- 17.BP Delay – Time from feed pump to high pressure pump/ETD (HH:mm:ss)
- 18.Salinity Level – Salinity error level (ppm)
- 19.Min Pressure – minimum pressure (Bar or PSI)
- 20.Min Pressure Time – Min pressure measure time (HH:mm:ss)
- 21.Max Pressure – Maximum pressure (Bar or PSI)
- 22.Sol. Valve Time – Solenoid valve time (seconds)

Configuration (Read) Menu

This menu monitors a selected list of configuration parameters, which may be of interest to the operator (e.g. units are metric or US, FWF time interval, etc.). This menu is appended to the Display Menu.

1. Unit – units (metric or US)
2. Low Pressure 1 Inst – S1 Lo pressure sensor installed (yes or no)
3. Low Press 2 Inst – S2 Lo pressure sensor installed (yes or no)
4. Prod Flow Inst – Product flow meter installed (yes or no)
5. Brine Flow Inst – Brine flow meter installed (yes or no)
6. Tank Full Inst – Tank level full sensor installed (yes or no)
7. Tank Empty Inst – Tank level empty sensor installed (yes or no)
8. Time to AutoShut – Auto shutdown after X hours in state FWP (HH:mm:ss)
9. AutoShut Time – Auto shutdown after time (yes or no)
- 10.AutoShut Tank – Auto shutdown on tank full (yes or no)
- 11.FWF Duration – FWF duration time (HH:mm:ss)
- 12.FWF Interval – FWF interval time (HH:mm:ss)
- 13.AutoStart Tank – Autostart on tank empty (yes or no)
- 14.Salinity Level – Salinity error level (ppm)
- 15.Min Pressure – minimum pressure (Bar or PSI)
- 16.Max Pressure – Maximum pressure (Bar or PSI)
- 17.Sol. Valve Time – Solenoid valve time (seconds)

Fresh Water Flush button

This button initiates the Fresh Water Flush (FWF) cycle. The cycle can be interrupted by pressing it again to stop operation. Note that this button starts the FWF cycle, regardless of whether or not you are browsing a menu.

Booster Pump button

Start the booster pump. Press the Start/Stop button to stop operation. Note that this button starts the booster pump, regardless of whether or not you are browsing a menu.

6.0 MAINTENANCE & REPAIR

6.1 GENERAL

The service life of most of the system equipment is directly related to the raw water inlet conditions. Improper maintenance will also significantly reduce the life expectancy of the major unit components (such as the membranes, filters, and pumps) as well as the reliability of the unit. Under normal conditions, and with proper maintenance, a reverse osmosis membrane (which is the major consumable item) should have an effective service life somewhere between 3 to 5 years.

	Daily	Weekly	Monthly	Quarterly	Semi-Annually	Annually (300 HRS)	As Required	Labor Hours (approximate)
Fresh Water Flush		•						0.1
Replace micron filter(s)							•	0.5
Fresh Flush Charcoal Filter Replacement					•			0.2
Air/Oil Separator						•		0.5
Sea Strainer		•						0.2
Inspect High-Pressure Pumps for leakage						•		0.1
Replace membranes							•	1.0
Clean membranes							•	2.0
Transducer							•	0.5
High Pressure Pump Oil							•	0.1
Replace Pump Seal Kit							•	0.5
Replace Pump Valve Kit							•	0.5
UV Sterilizer – Clean Quarts Sleeve							•	0.2

Table 6.0 - Maintenance Task Chart

6.2 MICRON FILTER ELEMENT REPLACEMENT

The 5-micron Prefilter elements (FIL-1 & FIL-2) should be replaced when the differential pressure across the filter and inlet of the system exceeds 20 psi (1.4 BAR). A shutdown alarm will occur on the

inlet of the unit when pressure is under 6 psi (0.35 BAR).

7 TROUBLESHOOTING

7.1 System Shuts Down During Operation

NUMBER ONE REPORTED PROBLEM IS "THE SYSTEM DOESN'T WORK!"

Detail and record everything happening with the system. Read Chapter 7 of the manual, see if some of the problems listed and the solutions applies to the commissioned system. Parker's technical support team can help you if there are any further questions.

NUMBER TWO REPORTED PROBLEM IS "System Shuts Down by Itself" with "ERROR ID 2" or "ERROR ID 3" (High/LowPressure Fault)

1. To clear the alarm or "fault" Press Start/Stop Button
2. While observing Low- and High-Pressure Gauges Start System:
 - a. **ERROR ID 2:** If the High-Pressure Sensor increases beyond 950 PSI and the unit shuts down, Start the unit again and check the Brine Discharge Section as well as the Product Line Section, make sure:
 - No kinks or blockages are in the Brine Discharge Line
 - No kinks or blockages are in the Product Water Line
 - b. **ERROR ID 3:** If the Low-Pressure sensor decreases to near or below 6 PSI, check the inlet line and associated components prior to the High-Pressure Pump Inlet:
 - Sea cock valve must be fully open.
 - Check for air suction leaks at all components and fittings prior to the Boost Pump
 - Check sea strainer screen and clean/clear debris. Check for any suction leaks.
 - Check the prefilter Element clean manufacturing or installation debris.
 - Check the plankton Filter Element clean manufacturing or installation debris.
 - No kinks or blockages in the inlet line and check for air suction leaks.
 - Ensure that the boost Pump is operational and delivering flow and pressure.
 - Check Inlet Thru-Hull Fitting clean manufacturing or installation debris and check for air suction leaks.
 - Check if there is any caulking compound in the thru hull opening, and that all shipping covers and tape on the hull has been removed. Shipping cover or tape below the hull in the water.
 - Check for a Plastic bag or other debris in the water below the hull in the water.
3. Please read this carefully: Debris may plug up the Prefilter Element causing the system to shut down. After shutdown, that same debris may settle off of the prefilter element and down into the prefilter housing bowl. Re-starting of the system may initially give normal readings. However, after a short period of time, the debris will stir up and once again clog the prefilter element causing the system to shut down due to low pressure.

Another cause may be an air suction leak at or prior to the Booster Pump (suction line at or prior to the Inlet of the Booster Pump). Within up to 10 minutes of operation, if the Low-Pressure Gauge gradually decreases to near or below 6 PSI, check the inlet line and associated components prior to the Boost Pump Inlet:

- Sea strainer Mesh Screen (clean all debris and check for air suction leak).
 - Prefilter Elements (may need to be cleaned or replaced).
 - Plankton Filter Element (clean all debris from screen).
 - Inlet Thru-Hull Fitting for debris, underneath the boat, and check for air suction leaks.
 - Sea cock Valve must be fully opened and checked for air suction leaks
 - No kinks or blockages in the inlet line
 - Check for air suction leaks from each fitting.
 - Ensure that the Booster Pump is operational and delivering flow and pressure
4. If system shuts down due to low or high pressure prematurely, then either the Low-Pressure or the High-Pressure transducer may require adjustment or replacement. Refer to High- and Low-Pressure transducer Troubleshooting as well as High- and Low-Pressure Gauge Troubleshooting.

5. System Shuts Down By Itself

- Voltage may have been interrupted causing the system to shut down. Check Voltage at the system inside the Control Panel. The system must receive adequate voltage at start up and during operation in order for it to operate normally.
- AC systems shut down by design when the voltage falls below 10% of the set voltage
- Check power cable wire size from the power source to the system to ensure that it is not undersized and causing voltage drop to the system. Check power cable wire connections from the power source to the system to ensure that they are tight.

6. System Shuts Down by Itself and does not Start when the "Start" switch is pressed

Check power source circuit breaker.

- If the breaker has tripped and if this is a continual problem, check circuit breaker amperage rating to ensure that the proper circuit breaker has been installed.
- Occasionally a circuit breaker can be "weak" or defective causing premature trip.
- Have a qualified electrician check the circuit breaker with a full rated load to test its integrity.
- Check Power Wire Size to ensure that it is proper for the amperage rating of the system. Undersize wire will cause voltage drop and increased current.

7. System Shuts Down when the Operating pressure is less than 950 PSI

Inspect the pressure gauge orifice inside the High-Pressure Gauge port and dislodge debris within the orifice by cleaning or opening the hole with a small drill bit 1/32-inch (1 mm) diameter. Replace Gauge if necessary.

7.2 Product Water Flow and Product Water Quality

“The system is operating at 850 psi and is not producing specified product water flow.”

1. **Feed Water salinity is greater than 35,000 PPM:** Higher salinity Feed Water Requires higher pressure to make rated flow. Refer to Salinity Effects in Chapter 3 to identify expected pressure for Higher salinity feed waters. Do not exceed 950 psi operating pressure.
2. **System Feed Water temperature is lower than 77°F / 25°C:** Lower temperature feed water requires higher operating pressure to make rated flow. Refer to Temperature Effects chart in this manual to identify expected pressure for lower temperature Feed Waters. Do not exceed 950 psi operating pressure.
3. **NEW System Initial Commissioning:** The RO Membrane Element may have dried out between the time of installation and the time of commissioning. Contact the factory if this time period is uncertain. If this may be the situation, then operate system pressurized for 48 hours continuous to saturate and hydrate the RO Membrane Element. Only do this if it is known that the system was shipped months prior to installation and commissioning was performed months after installation, or if it is known that the RO Membrane Element has dried out.
4. **RO Membrane Element has been in use for a period of time and is fouled from use:** If RO Membrane Element has been stored improperly without proper flushing and/or storage solution or if it has simply slowly degraded over time and use, then the membrane may be fouled and cleaning may restore performance. If not, membrane should be replaced.
5. **Membrane has chemical fouling:** If RO Membrane Element has been performing normally and the drop in production was sudden over one or two times of use it may be chemically fouled by petroleum or other pollutants.
6. **Membrane has dried out:** If it is known that the RO Membrane Element has dried out operate system pressurized for 48 hours continuous to saturate and hydrate the RO Membrane Element.
7. **RO Membrane Element has been exposed to temperatures in excess of 140°F / 60°C:** Replace RO Membrane Element.
8. **There may be a restriction in the product water line:** Ensure that any valve in the product water line is fully open. Note: It is preferred and recommended that there are no valves in the Product Water Line. Ensure that any valve in the product water line is tight, a loose or easily turning valve handle will move and reposition itself due to the movement and pounding of the boat.

System produces more than rated product water flow when operating from full seawater salinity of 35,000 ppm or higher and the operating pressure is 400 PSI or lower and the Product Water Quality Lamp is illuminated “red.”

1. A mechanical failure exists in the RO Membrane Element and/or High-Pressure Vessel.
2. Cracked or broken RO Membrane Element product water tube which is caused by a

blockage in the Product Water Line during operation

3. Cracked End Plug in the High-Pressure Vessel allowing seawater to mix with Product Water which is caused by over tightening of tapered pipe fittings into the End Plug
4. Damaged or worn Product Water O-ring in the High-Pressure Vessel End Plug
5. Lamination failure within the RO Membrane Element which is caused by a blockage in the Product Water Line and/or air entrapment in the High-Pressure Vessel is normally associated with mounting the High-Pressure Vessels vertically rather than horizontally.

ERROR ID 1: System produces expected rated product water flow with normal operating pressure after compensating for Feed Water Salinity and Temperature and the Product Water salinity is above 1000 ppm for more than 10 consecutive seconds.

1. It is helpful to use a portable TDS meter to determine if the problem is with the RO Membrane Element or with the Salinity Probe and Electronic monitoring system.
2. Damaged or worn Product Water O-ring at one of the End Plugs within the High-Pressure Vessel is allowing Feed Water to mix with Product Water. This would usually result in higher than normal Product Water Flow. However, a small nick in the O-ring may allow enough Feed Water to mix with the Product Water to cause the condition without resulting in a noticeable increase in Product Water Flow.
3. Crack in one of the End Plugs within the High-Pressure Vessel is allowing Feed Water to mix with Product Water. This would usually also result in higher than normal Product Water Flow. However, a small crack may allow enough Feed Water to mix with the Product Water to cause the condition without resulting in a noticeable increase in Product Water Flow.
4. RO Membrane Element is fouled due to normal use and requires cleaning.
5. Salinity Probe has debris on the probe causing the system to read poor water quality. Clean the Salinity Probe with a toothbrush.
6. Salinity Monitor out of calibration. Test the actual Salinity of the product water using a portable TDS meter. The system switches from potable water to un-potable water at 800 PPM TDS. If the salinity of the Product Water is less than 800 PPM TDS, then calibrate the Salinity Monitor.

"The Water Quality is less than 1000ppm, but the water has a definite salt taste."

1. Blockage or pressure in excess of 55 psi is present in the brine discharge line.
 - A blocked brine discharge line causes brine water to mix with product at the Diversion Valve. Flow through the flow meter will be normal because the flow meter is prior to the 3-way product water diversion valve.
 - Ensure that the brine discharge line is free from kinks and that any valves installed in the brine discharge line are fully open.
2. Salinity Probe has debris on the probe causing the system to read good water quality. Clean the Salinity Probe with a toothbrush.

Product Water is leaking from the Product Tubing when the Water Quality is less than 1000ppm. Blockage or pressure in excess of 55 psi is present in the product outlet line from the system.

- Check all components and check for kinks or closed valves at and after the point of leakage.

- Charcoal Filter element is fouled, replace element
- pH Neutralizer element is fouled, replace element.
- 3-way Product Water Diversion Valve is blocked, or inner ports are out of adjustment, adjust inner ports.

There is a Sulfurous odor (rotten eggs) in the product tank.

1. Dirty Pre-Filtration Element.
 - Dirty Pre-Filtration Elements allow biological matter to decay. When this biological matter decomposes, sulfurgas is released as a byproduct.
 - Check and replace as necessary Prefiltration and Post Filtration Elements.
2. Charcoal Filter Element requires replacement. Change the Charcoal Filter Element every 3 months.
3. Product Tank is dirty or has biological growth in it. Clean and Chlorinate product tank.

The UV sterilizer is flickering or does not light. (Ultraviolet light will damage skin and eyes. Do not look directly at theUV lamp!)

1. UV lamp is weak due to length of time in use, in excess of 1,000 hours. Replace the UV lamp.
2. The UV ballast is very sensitive to voltage changes. Ensure that the voltage supplied to the UV sterilizer is within 11.5 VDC to 13 VDC.

7.3 3-way Product Water Diversion Valve Abnormalities

When the system is producing “unpotable” water and the Water Quality lamp is illuminated “red” the 3-way Product Water Diversion Valve coil will not receive voltage from the controller. This allows the 3-way Product Water Diversion Valve to divert the “unpotable” water to the Brine Discharge.

When the system is producing “potable” water and the Water Quality lamp is illuminated “green”, the 3-way Product Water Diversion Valve coil will receive 12 VDC from the controller. This allows the 3-way Product Water Diversion Valve to divert the “potable” water to the post filtration section and on to the boat’s potable water storage tank.

The Water Quality is less than 1000ppm, however, the Diversion Valve does not divert potable water to the post filtration section and on to the boat’s potable water storage tank.

The Diversion Valve is not energizing, and the valve’s coil is cool to the touch after several minutes of operation with the Water Quality is less than 1000ppm.

- The 3-way Product Water Diversion Valve may have a defective solenoid coil.
- There may be a loose wire connection at the Control Printed Circuit Board or the solenoid’s din connector.
- The Control Printed Circuit Board may not be delivering 12 VDC to the solenoid.

The 3-way Diversion Valve is receiving 12 VDC when the Water Quality less than 1000ppm safe

water and the valve's solenoid coil is not defective, the valve's solenoid coil is warm or hot to the touch, however the Diversion Valve does not divert potable water to the post filtration section and on to the boat's potable water storage tank.

The Diversion Valve internal ports may have been moved by over tightening of the black tube fittings causing blockage internally and require adjustment. Remove Diversion Valve from the system and adjust ports.

High Pressure Pump & Motor Abnormalities

Troubleshoot electric motor failure to ensure that any abnormality from the power, wiring, wiring connections, contactor, or control circuit are not at fault or at cause. If the electric motor has failed, it will require replacement. Depending upon failure, replacement may be more cost effective than repair. If failure of the motor is due to external source, not the motor itself, then correct the cause or else the replacement or repaired motor will fail again.

*Failures of the electric motor may be:

- Bearing failure: Replace motor.
- Winding failure: Generally caused by low or high power, below or above the specified voltage requirements of the system and feeding the motor. This is NOT economically repairable.
- Capacitor failure: Generally caused by low power feeding the motor. Also caused by rapidly repeating starting and stopping of the motor. Replace motor.

Potential Scenarios:

High Pressure Pump flow is normal when the system operating pressure is below 100 PSI, but the flow drops or becomes erratic and pulsates as pressure is applied.

- Worn High Pressure Seals from normal use require replacement.
- Worn High Pressure Pump valves, valve seats, valve springs and/or valve seat "O" rings are broken or worn due to normal use and are allowing internal by-passing. Repair the pump with a Valve and Seal Kit.

Pump is noisier than usual, and pulsations are observed in hoses and gauges.

- Worn or broken Valve, Valve Spring, or Valve Seat. Repair the pump with a Valve and Seal Kit.
- Pump is cavitating and not receiving sufficient feed water at its inlet due to blockage prior to the pump's inlet port. Clear the blockage in the feed water line.

High Pressure Pump Leaks Oil

Determine source of leak and replace appropriate associated seal.

High Pressure Pump leaks water between manifold and Drive End

- Worn Inlet Packings due to normal use.
- Worn Inlet Packings due to operation under a vacuum condition.
- Worn Inlet Packings because pump has been operated dry, without inlet feed water.

- Repair the pump with a Seal Kit.

If the High-Pressure Pump electric motor fails to operate, follow these steps to isolate the problem:

1. Ensure that the system is receiving proper power from the power source.
2. Press “Start” switch to activate the motor. It will take approximately 10 seconds before the High-Pressure Pump Motor starts. Do not press any other switch.
3. Measure the AC voltage between terminals 4 and 5 (AC Systems) on the main terminal strip.
4. If the voltage measured in the step 3 above matches the system voltage, then problems may be in the power cable attached to the motor or the motor internal wiring or windings.
5. If low or no voltage is present in step 3 above, then check for proper operation of the High-Pressure Pump Contactor. To deactivate the contactor, press the “Stop” switch twice. To activate the contactor again, press the “Start” switch.
6. If the contactor is mechanically operating, but no voltage is present at the motor terminal (step 3 above), then the High-Pressure Pump Motor contactor may be at fault.
7. If the contactor does not operate mechanically, then measure the DC voltage between A1 and A2 terminals on the High-Pressure Pump Motor contactor coil. It should read 12V DC when activated.
8. If the contactor coil is receiving 12V DC but inoperative then the contactor’s coil may be bad. Replace the contactor.
9. If 12V DC is not present when the High-Pressure Pump is activated, trace the orange and orange/black wires to the main circuit board and measure the DC voltage at the terminals. It should read 12V when activated.

7.4 Booster Pump Abnormalities

If the Booster Pump electric motor fails to operate, follow these steps to isolate the problem:

1. Ensure that the system is receiving proper power from the power source.
2. Press “Booster Pump” switch to activate the motor. Do not press any other switch.
3. Measure the AC voltage between Terminals 1 and 2 on the main terminal strip in the controller.
4. If the voltage measured in the step 3 above matches the system voltage, then problems may be in the power cable attached to the motor or the motor internal wiring or windings.
5. If low or no voltage is present in step 3 above, then check for proper operation of the Booster Pump Contactor. To deactivate the contactor, press the “Stop” switch twice. To activate the contactor again, press the “Booster Pump” switch.
6. If the contactor is mechanically operating, but no voltage is present at the motor terminal (step 3 above), then the Booster Pump Motor contactor may be at fault.
7. If the contactor does not operate mechanically, then measure the DC voltage between A1 and A2 terminals on the Booster Pump Motor contactor coil. It should read 12V DC when activated.
8. If the contactor coil is receiving 12V DC but inoperative then the contactor’s coil

may be bad. Replace the contactor.

9. If 12V DC is not present when the Booster Pump is activated, trace the yellow and yellow/black wires to the Control Printed Circuit Board and measure the DC voltage at the terminals. It should read 12V when activated.

7.5 Electrical and Electronic Circuit Abnormalities

The Start Switch is pressed, but the system does not attempt to start.

1. System is in Fresh Water Flush Mode. Press Stop to exit Fresh Water Flush Mode. Press Start to operate the system.
2. The LCD on the Touch Pad is not illuminated.
 - Reset the system circuit breaker.
 - There is no main Power to the system from the Power Source, investigate, and correct.
3. Improper wiring. Ensure that system is wired correctly and that there are no loose wire connections.
4. Inadequate power source to the system.
 - Ensure that the voltage does not drop below the industry standard of 10% of the full operating voltage set for the system. If the voltage drops below this standard during the system startup, the system will not start. High current is necessary to “excite” the electric motors. At the time of attempting to start the electric motors, they will consume high current. This may cause the voltage from the Power Source to drop dramatically for a fraction of a second which can be enough to cause the electronic circuit to shut off.
 - Provide adequate power to the system.
5. Defective Start Switch on Touch Pad.
 - Test with Substitute Touch Pad.
 - Replace Touch Pad if one or more lamps or switches are found to be inoperable.

The Stop Switch is pressed, but the system does not stop.

1. Microprocessor has locked up. Turn main power off to the system at the power source circuit breaker for a minimum of 30 seconds to reset the microprocessor.
2. Defective Stop Switch on Touch Pad.
 - Test with Substitute Touch Pad.
 - Replace Touch Pad if one or more lamps or switches are found to be inoperable.
3. Water damage to printed circuit board.
 - Inspect Printed Circuit board for presence of water or corrosion from water.
 - If board had water spilled on it remove board from system, flush with distilled water, and thoroughly dry with hair dryer. Place board in low humidity area for minimum 24 hours. Shake the board to ensure that no water is left on the board. Reinstall and attempt to operate the system. If there is any sign of corrosion from water damage,

replace it.

Product Water 3-way Diversion Valve does not switch to “safe water,” potable water.

1. First see "3-WAY PRODUCT WATER DIVERSION VALVE ABNORMALITIES" in part C, Chapter 7.
2. The Water Quality greater than 1000ppm the 3-way Product Water Diversion Valve is not energized; it is sending the Product Water to Brine Discharge overboard. Using a handheld TDS Meter check the salinity of the Product Water. If the Salinity of the Product Water is greater than 800 PPM TDS, then the Salinity controller is reading properly and diverting the “unpotable water” Product Water by not energizing the 3-way Diversion Valve. This is normal and the problem lies in the RO Membrane Element. See "PRODUCT WATER FLOW AND PRODUCT WATER QUALITY," section 7.2.
3. The 3-way Product Water Diversion Valve is not energized; it is sending the Product Water to Brine Discharge overboard.



Danger: ELECTRICAL SHOCK HAZARD. A Volt / Ohm Meter will be necessary. The following procedures expose the technician to High Voltage and electrical shock hazard. Only attempt this if you are a qualified electrician and only if surrounding conditions are safe.

- With the system in operation and The Water Quality less than 1000ppm , remove the Controller Enclosure front panel to expose the inside of the controller box components.
- With the system in operation and The Water Quality less than 1000ppm, measure the voltage at the terminals labeled 3-Way Product Water Diversion Valve. The voltage should be 12 VDC.
- If no voltage is present replace the Control Printed Circuit Board.
- If 12 VDC is present, see "PRODUCT WATER FLOW AND PRODUCT WATER QUALITY" in Part B, Chapter 7.

Product Water salinity is confirmed (verified with a handheld TDS meter) to be less than 800 PPM TDS, however the water quality LED is illuminated RED “unpotable water.”

7.6 Maintenance and Repair

Are you mechanically inclined?

Troubleshooting and subsequent correction or repair will require understanding of:

- Electrical Circuits
- Electronic Circuits
- Electric Motors
- Hydraulic Systems
- Liquid Pressures and Flows
- Electromechanical Systems
- Mechanical knowledge and skills

Do not attempt troubleshooting and/or subsequent correction or repair if you are not familiar

with or are not proficient in the above fields of expertise.

USE CAUTION WHEN TROUBLESHOOTING. DO NOT PERFORM MAINTENANCE UNLESS:

1. The system Feed Water Sea Cock Valve [2] is closed.
2. The system main electrical disconnect switch is switched "OFF", LOCKED, and TAGGED
3. The "EXPLODED PARTS VIEWS" of this manual is available.

 **Caution:** ELECTRICAL SHOCK HAZARD. A Volt / Ohm Meter will be necessary. The following procedure expose the technician to High Voltage and electrical shock hazard. Only attempt this if you are a qualified electrician and only if surrounding conditions are safe.

7.7 Weekly Quick Check

The following steps ensure that potential problems are resolved preventing major repairs:

1. Inspect all fasteners for tightness including brackets, screws, nuts, and bolts. Pay special attention to the High-Pressure Pump and Electric Motor since they are subject to increased vibration.
2. Ensure that Sea Strainer, if installed, is clean and does not restrict flow.
3. Check the level of the High-Pressure Pump crankcase oil. The minimum oil level is the center of the sightglass, located at the side of the High-Pressure Pump; the maximum oil level is at the top of the sight glass window. Use only Parker High Pressure Pump oil. **DO NOT USE MOTOR OR OTHER HYDRAULIC OIL.**
4. Clean any salt water or salt deposits from the system with a wet rag.
5. Check for fluid leaks; either oil from the High-Pressure Pump or water from anywhere in the system.
6. Check all tubing and high-pressure hoses for wear and friction against abrasive surfaces. The hoses should not contact heated or abrasive surfaces.
7. Check Inlet Pressure to the High-Pressure Pump. If pressure is below 10 psi after 5 minutes of operation, replace Pre-Filter element.

7.8 Operator Maintenance Intervals

The frequency of required maintenance is dependent on the regularity of usage, the condition of the intake water (the location of use), the length of time the system is exposed to water, the total running time and, in some cases, the manner in which the system is installed or operated. Use Table 6 in chapter 6 as a general guideline for maintenance timeline

8. DRAWINGS & DIAGRAMS

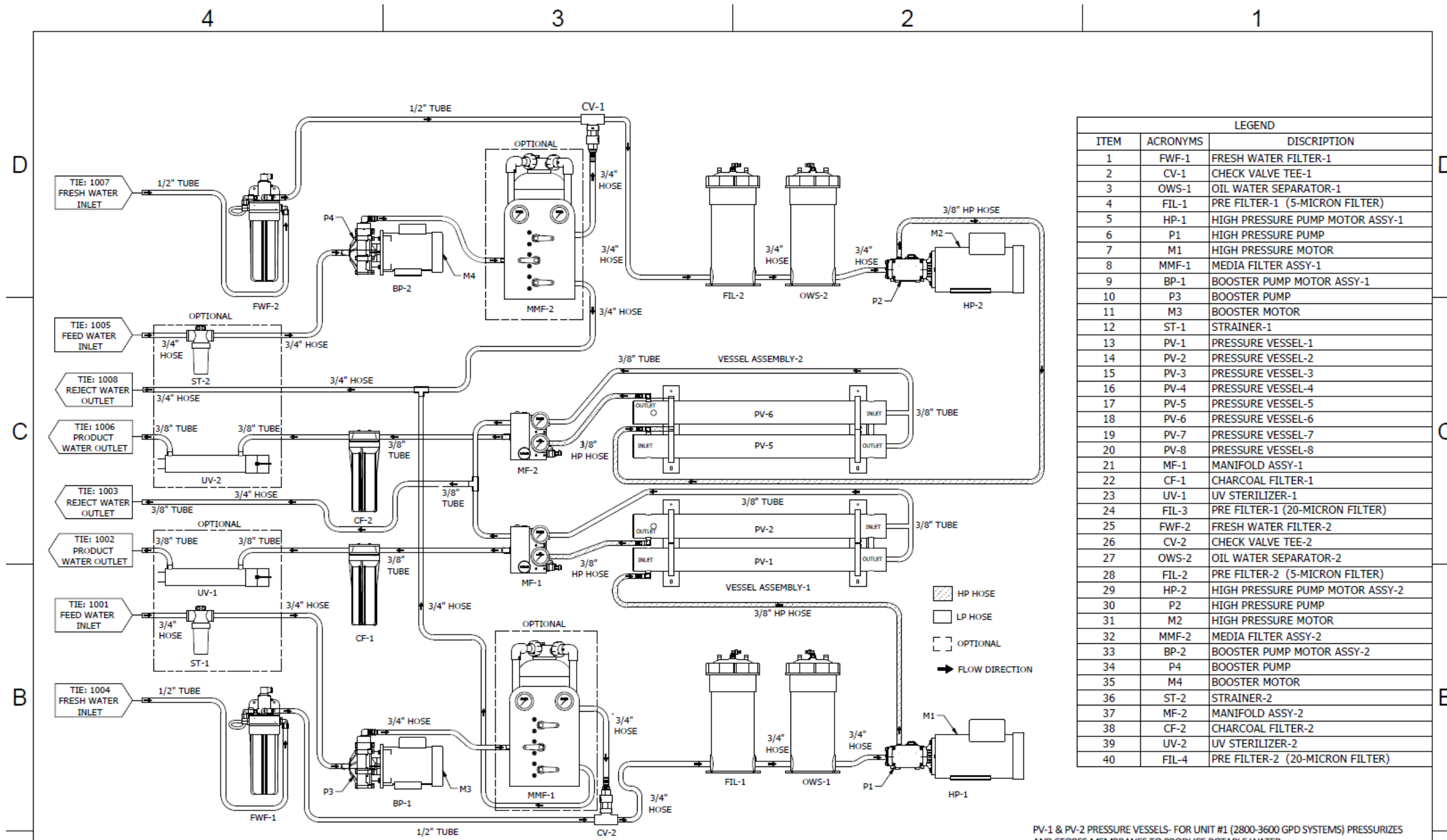

LEGEND		
ITEM	ACRONYMS	DISCRIPTION
1	FWF-1	FRESH WATER FILTER-1
2	CV-1	CHECK VALVE TEE-1
3	OWS-1	OIL WATER SEPARATOR-1
4	FIL-1	PRE FILTER-1 (5-MICRON FILTER)
5	HP-1	HIGH PRESSURE PUMP MOTOR ASSY-1
6	P1	HIGH PRESSURE PUMP
7	M1	HIGH PRESSURE MOTOR
8	MMF-1	MEDIA FILTER ASSY-1
9	BP-1	BOOSTER PUMP MOTOR ASSY-1
10	P3	BOOSTER PUMP
11	M3	BOOSTER MOTOR
12	ST-1	STRAINER-1
13	PV-1	PRESSURE VESSEL-1
14	PV-2	PRESSURE VESSEL-2
15	PV-3	PRESSURE VESSEL-3
16	PV-4	PRESSURE VESSEL-4
17	PV-5	PRESSURE VESSEL-5
18	PV-6	PRESSURE VESSEL-6
19	PV-7	PRESSURE VESSEL-7
20	PV-8	PRESSURE VESSEL-8
21	MF-1	MANIFOLD ASSY-1
22	CF-1	CHARCOAL FILTER-1
23	UV-1	UV STERILIZER-1
24	FIL-3	PRE FILTER-1 (20-MICRON FILTER)
25	FWF-2	FRESH WATER FILTER-2
26	CV-2	CHECK VALVE TEE-2
27	OWS-2	OIL WATER SEPARATOR-2
28	FIL-2	PRE FILTER-2 (5-MICRON FILTER)
29	HP-2	HIGH PRESSURE PUMP MOTOR ASSY-2
30	P2	HIGH PRESSURE PUMP
31	M2	HIGH PRESSURE MOTOR
32	MMF-2	MEDIA FILTER ASSY-2
33	BP-2	BOOSTER PUMP MOTOR ASSY-2
34	P4	BOOSTER PUMP
35	M4	BOOSTER MOTOR
36	ST-2	STRAINER-2
37	MF-2	MANIFOLD ASSY-2
38	CF-2	CHARCOAL FILTER-2
39	UV-2	UV STERILIZER-2
40	FIL-4	PRE FILTER-2 (20-MICRON FILTER)

PLUMBING DIAGRAM FOR 2800-3600 GPD SYSTEM

PV-1 & PV-2 PRESSURE VESSELS- FOR UNIT #1 (2800-3600 GPD SYSTEMS) PRESSURIZES AND STORES MEMBRANES TO PRODUCE POTABLE WATER
 PV-5 & PV-6 PRESSURE VESSELS- FOR UNIT #1 (2800-3600 GPD SYSTEMS) PRESSURIZES AND STORES MEMBRANES TO PRODUCE POTABLE WATER

NOTE : OPTIONAL PARTS

DISCRIPTION	PART NUMBER
20 MICRON PRE FILTER (PF)	07620310
U.V. STERILIZER (UV)	40000300CV
STRAINER ASSY (ST)	33-0340
MEDIA FILTER SMALLER ASSEMBLY UNIT	0151010
MEDIA FILTER LARGER ASSEMBLY UNIT	0151009

TIE POINT CONNECTION

TIE	DESCRIPTION	CONNECTION
1001	FEED WATER INLET	3/4" NYLON HOSE BARB
1002	PRODUCT WATER OUTLET	3/8" PP TUBE CONNECT
1003	REJECT WATER OUTLET	3/4" NYLON HOSE BARB
1004	FRESH WATER INLET	3/8" PP TUBE CONNECT
1005	FEED WATER INLET	3/4" NYLON HOSE BARB
1006	PRODUCT WATER OUTLET	3/8" PP TUBE CONNECT
1007	FRESH WATER INLET	3/8" PP TUBE CONNECT
1008	MEDIA FILTER REJECT OUTLET	3/4" NYLON HOSE BARB

PROPRIETARY STATEMENT
 THIS DOCUMENT CONTAINS INFORMATION THAT IS CONFIDENTIAL AND PROPRIETARY TO PARKER WATER PURIFICATION ("PARKER"). THIS DOCUMENT IS FURNISHED ON THE UNDERSTANDING THAT THE DOCUMENT AND THE INFORMATION IT CONTAINS WILL NOT BE COPIED OR DISCLOSED TO OTHERS OR USED FOR ANY PURPOSE OTHER THAN CONDUCTING BUSINESS WITH PARKER, AND WILL BE RETURNED AND ALL FURTHER USE DISCONTINUED UPON REQUEST BY PARKER. THE RECIPIENT OF THIS DOCUMENT THROUGH ITS OWN ANALYSIS AND TESTING IS SOLELY RESPONSIBLE FOR MAKING THE FINAL SELECTION OF THE APPLICABLE SYSTEMS AND COMPONENTS AND ASSURING THAT ALL PERFORMANCE, ENDURANCE, MAINTENANCE, SAFETY AND WARNING REQUIREMENTS OF THE APPLICATION ARE MET. COPYRIGHT PARKER, YEAR OF COPYRIGHT IS FIRST YEAR INDICATED ON THIS DOCUMENT. ALL RIGHTS RESERVED.

DIMENSIONAL TOLERANCES - UNLESS OTHERWISE SPECIFIED		CUSTOMER -	
FRACTION	MACHINED	WELDMENT	PROJECT -
X	±.1"	±.2mm	DATE - 12/14/2021
XX	±.01"	±.25mm	CHECKED - DATE -
XXX	±.005"	±.025mm	APPROVED - DATE -
ANGULAR ± 1°		DRY WT:	REV -
UNLESS OTHERWISE SPECIFIED		WET WT:	SCALE NTS
		CONTRACT NO:	1 OF 4

Parker
 Parker Hannifin Corporation
 Filtration Group / Water Purification
 2635 E. El Prado Street
 Carson, CA 90810
 Contact: 310-804-6600
 Fax: 310-804-6892
 www.parker.com

PLUMBING DIAGRAM FOR 2800 GPD - 6800 GPD
 A455C-PD

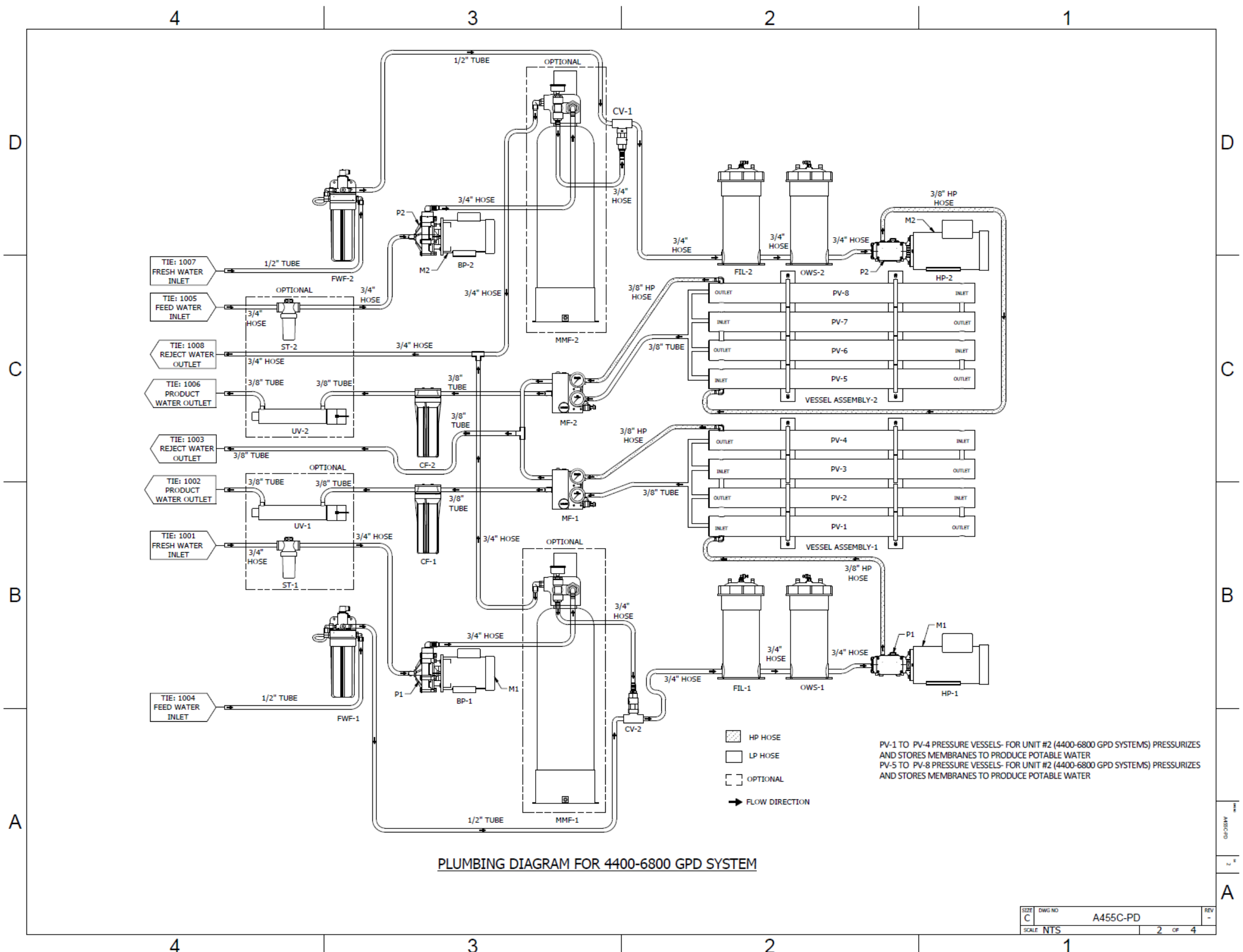

PLUMBING DIAGRAM FOR 4400-6800 GPD SYSTEM

SIZE	DWG NO	REV
C	A455C-PD	-
SCALE	NTS	2 OF 4

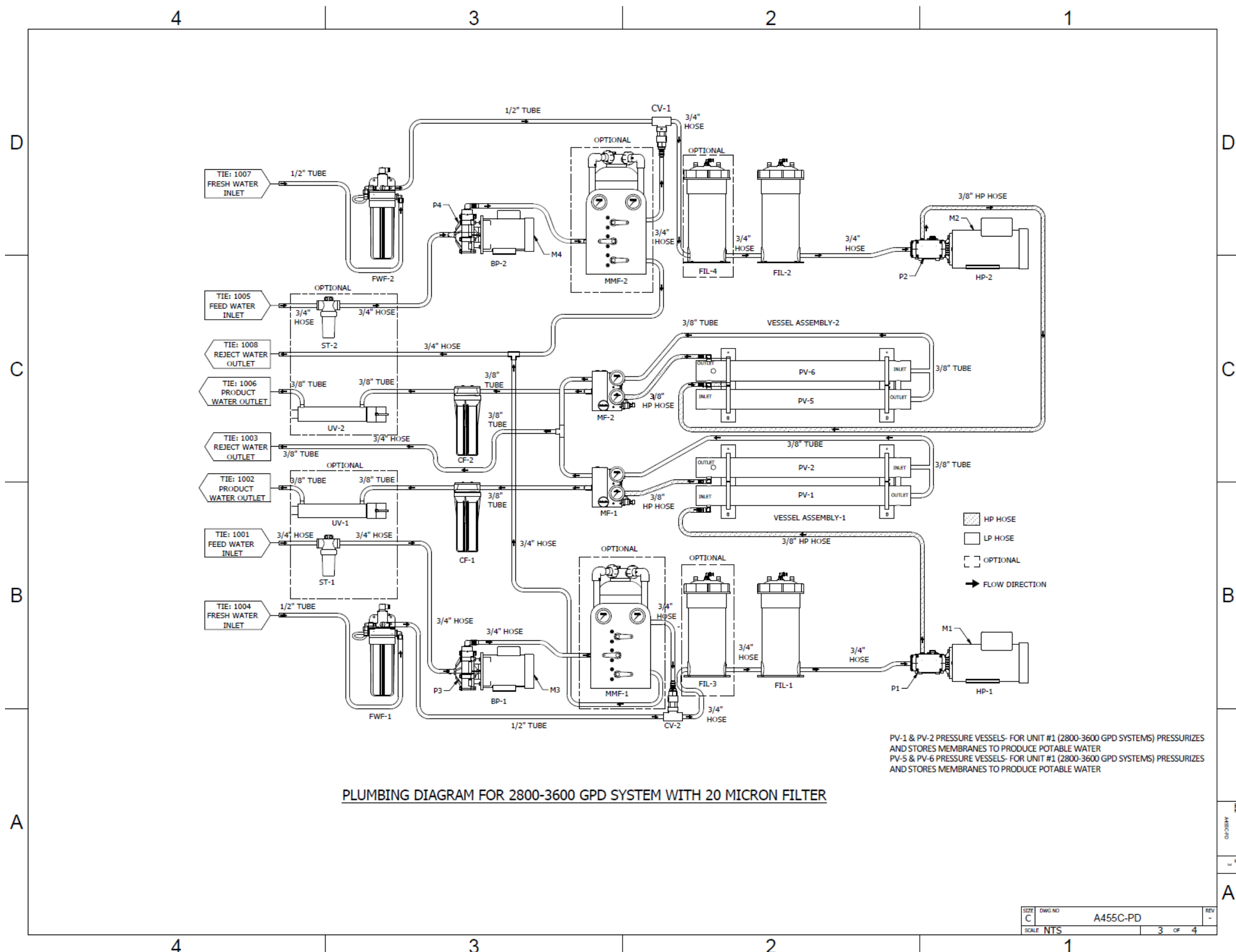

SIZE	DWG NO	REV
C	A455C-PD	-
SCALE	NTS	3 OF 4

2- GA Drawing:

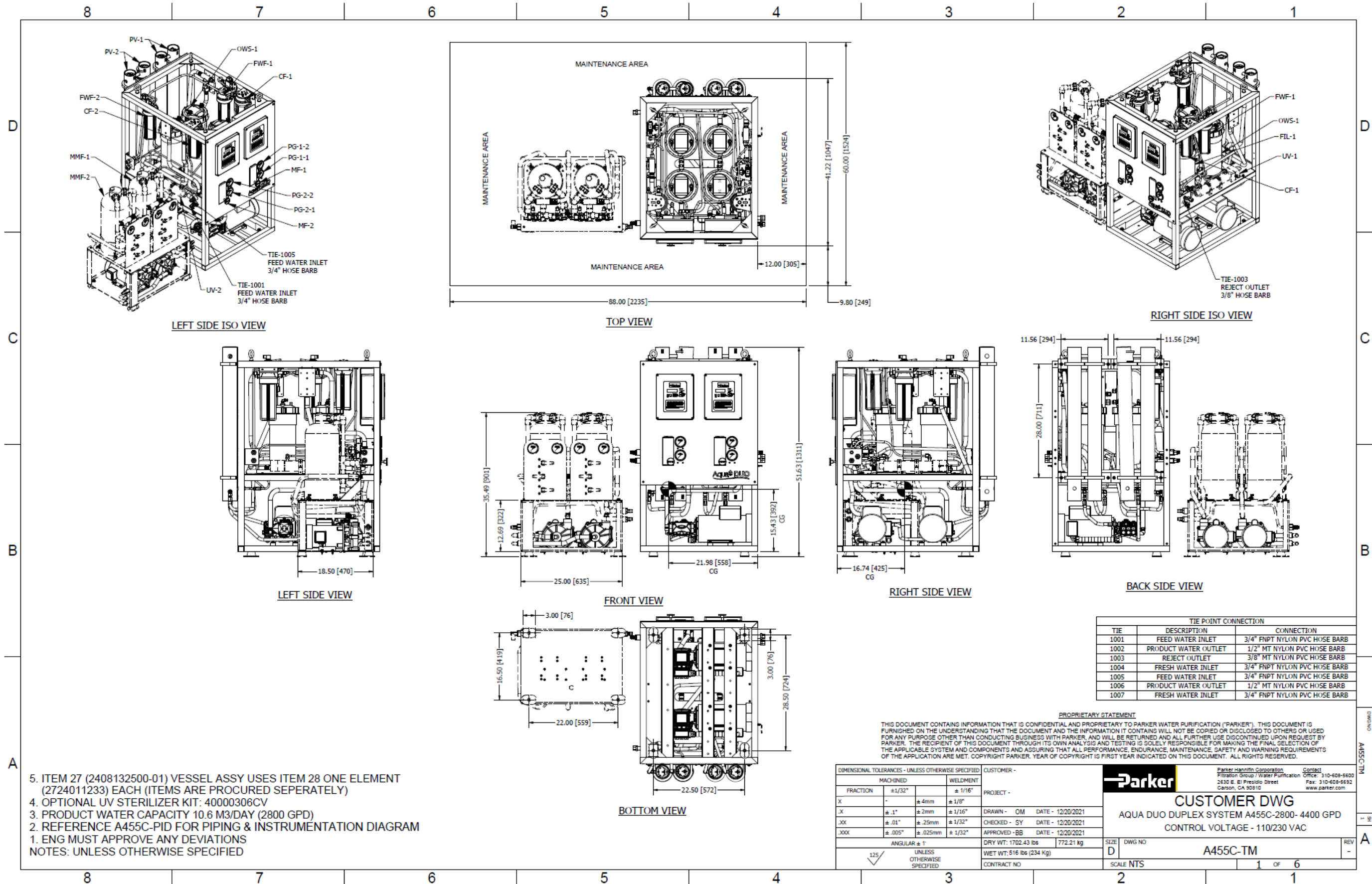

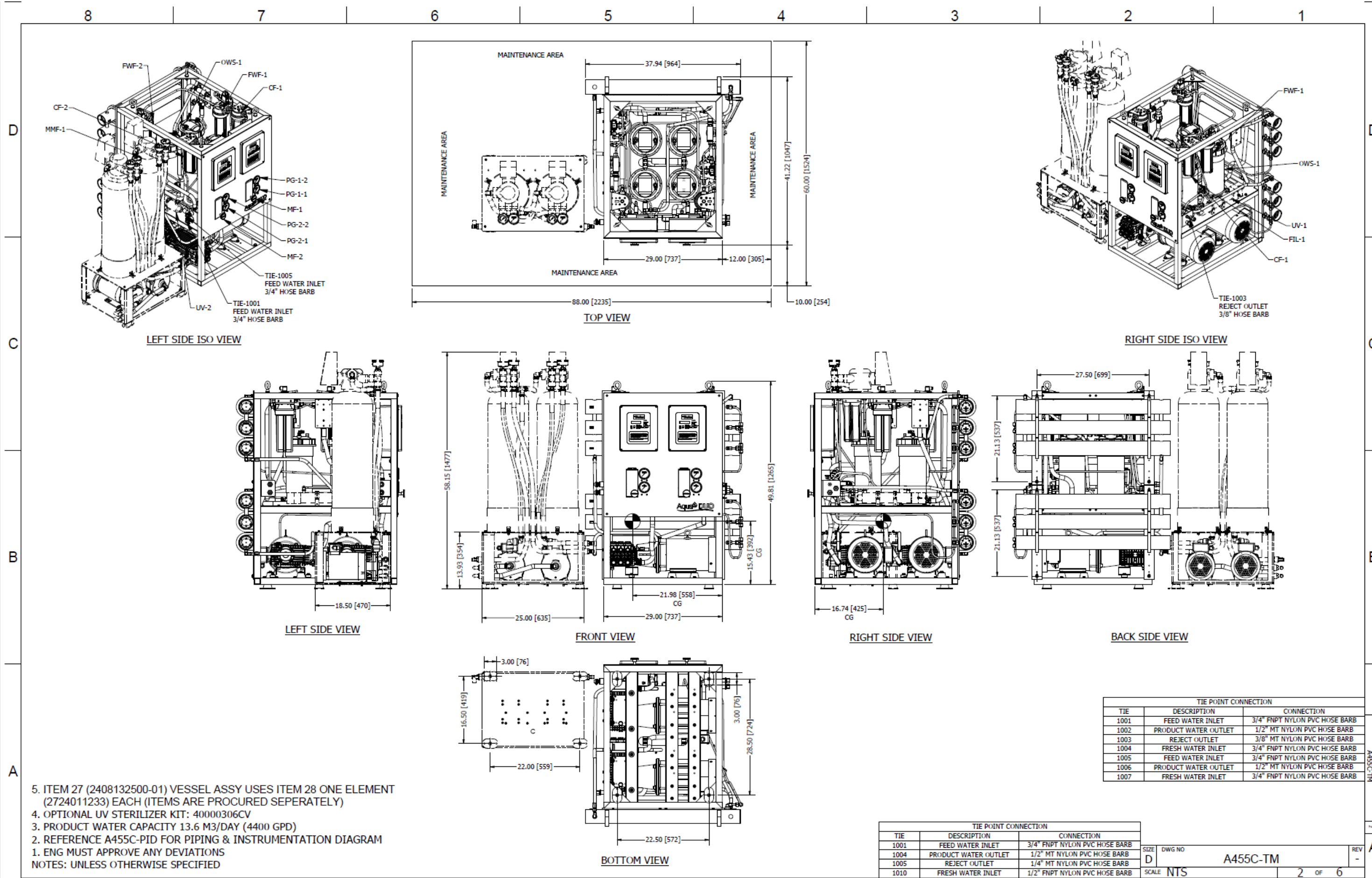

- 5. ITEM 27 (2408132500-01) VESSEL ASSY USES ITEM 28 ONE ELEMENT (2724011233) EACH (ITEMS ARE PROCURED SEPERATELY)
 - 4. OPTIONAL UV STERILIZER KIT: 40000306CV
 - 3. PRODUCT WATER CAPACITY 13.6 M3/DAY (4400 GPD)
 - 2. REFERENCE A455C-PID FOR PIPING & INSTRUMENTATION DIAGRAM
 - 1. ENG MUST APPROVE ANY DEVIATIONS
- NOTES: UNLESS OTHERWISE SPECIFIED

TIE POINT CONNECTION		
TIE	DESCRIPTION	CONNECTION
1001	FEED WATER INLET	3/4" FNPT NYLON PVC HOSE BARB
1002	PRODUCT WATER OUTLET	1/2" MT NYLON PVC HOSE BARB
1003	REJECT OUTLET	3/8" MT NYLON PVC HOSE BARB
1004	FRESH WATER INLET	3/4" FNPT NYLON PVC HOSE BARB
1005	FEED WATER INLET	3/4" FNPT NYLON PVC HOSE BARB
1006	PRODUCT WATER OUTLET	1/2" MT NYLON PVC HOSE BARB
1007	FRESH WATER INLET	3/4" FNPT NYLON PVC HOSE BARB

TIE POINT CONNECTION		
TIE	DESCRIPTION	CONNECTION
1001	FEED WATER INLET	3/4" FNPT NYLON PVC HOSE BARB
1004	PRODUCT WATER OUTLET	1/2" MT NYLON PVC HOSE BARB
1005	REJECT OUTLET	1/4" MT NYLON PVC HOSE BARB
1010	FRESH WATER INLET	1/2" FNPT NYLON PVC HOSE BARB

SIZE	DWG NO	REV
D	A455C-TM	-
SCALE	NTS	2 OF 6

DWG NO: A455C-TM
 REV: -
 SCALE: NTS
 SHEET: 2 OF 6

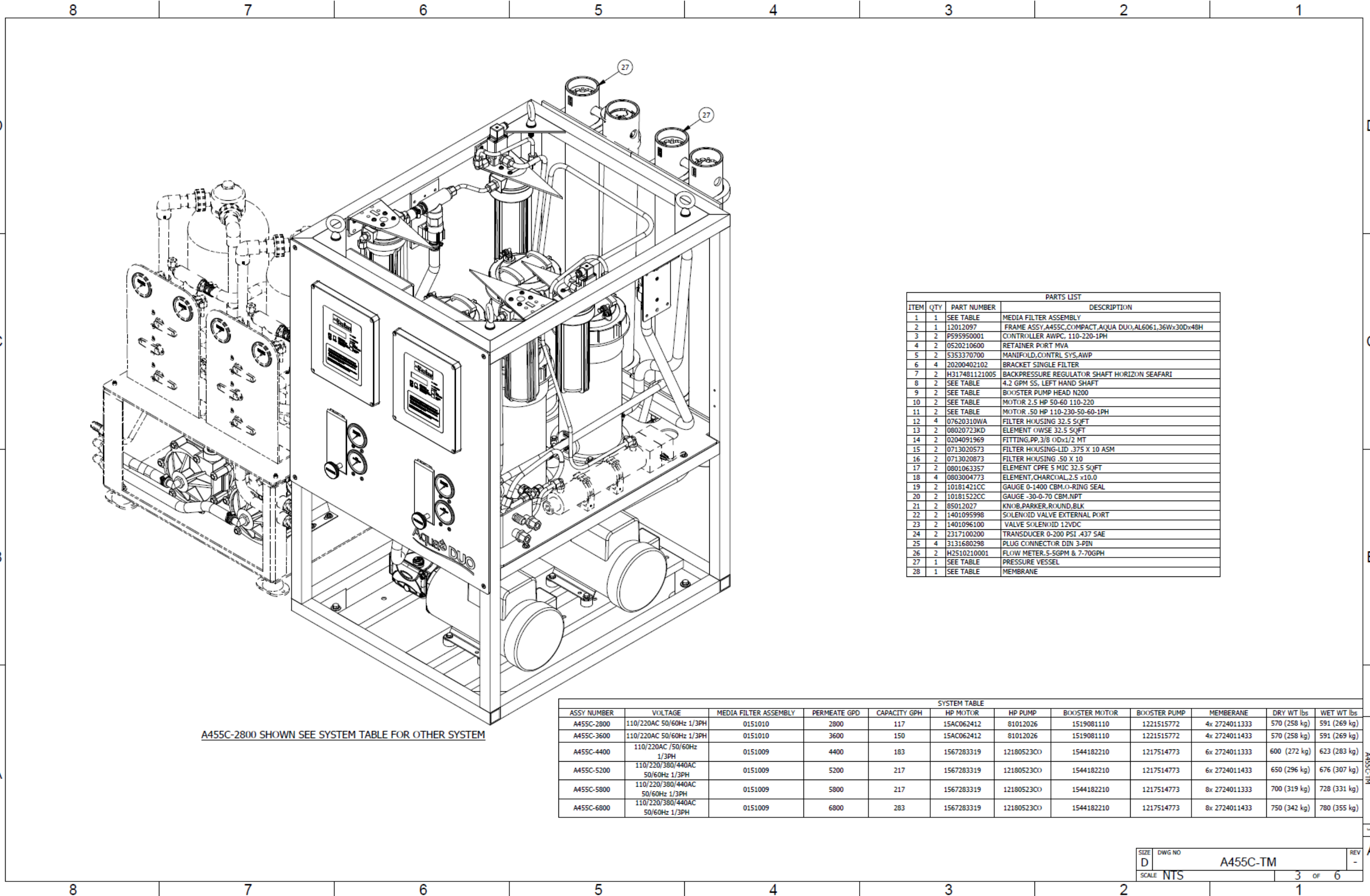

A455C-2800 SHOWN SEE SYSTEM TABLE FOR OTHER SYSTEM

PARTS LIST			
ITEM	QTY	PART NUMBER	DESCRIPTION
1	1	SEE TABLE	MEDIA FILTER ASSEMBLY
2	1	12012097	FRAME ASSY,A455C,COMPACT,AQUA DUO,AL6061,36Wx30Dx48H
3	2	P595950001	CONTROLLER AWPC, 110-220-1PH
4	2	0520210600	RETAINER PORT MVA
5	2	5353370700	MANIFOLD,CONTRL SYS,AWP
6	4	20200402102	BRACKET SINGLE FILTER
7	2	H317481121005	BACKPRESSURE REGULATOR SHAFT HORIZON SEAFARI
8	2	SEE TABLE	4.2 GPM SS, LEFT HAND SHAFT
9	2	SEE TABLE	BOOSTER PUMP HEAD N200
10	2	SEE TABLE	MOTOR 2.5 HP 50-60 110-220
11	2	SEE TABLE	MOTOR .50 HP 110-230-50-60-1PH
12	4	07620310WA	FILTER HOUSING 32.5 SQFT
13	2	08020723KD	ELEMENT OWSE 32.5 SQFT
14	2	0204091969	FITTING,PP,3/8 ODx1/2 MT
15	2	0713020573	FILTER HOUSING-LID .375 X 10 ASM
16	2	0713020873	FILTER HOUSING .50 X 10
17	2	0801063357	ELEMENT CPFE 5 MIC 32.5 SQFT
18	4	0803004773	ELEMENT,CHARCOAL,2.5 x10,0
19	2	10181421CC	GAUGE 0-1400 CBM,O-RING SEAL
20	2	10181522CC	GAUGE -30-0-70 CBM,NPT
21	2	85012027	KNOB,PARKER,ROUND,BLK
22	2	1401095998	SOLENOID VALVE EXTERNAL PORT
23	2	1401096100	VALVE SOLENOID 12VDC
24	2	2317100200	TRANSDUCER 0-200 PSI .437 SAE
25	4	3131680298	PLUG CONNECTOR DIN 3-PIN
26	2	H2510210001	FLOW METER,5-5GPM & 7-70GPH
27	1	SEE TABLE	PRESSURE VESSEL
28	1	SEE TABLE	MEMBRANE

SYSTEM TABLE											
ASSY NUMBER	VOLTAGE	MEDIA FILTER ASSEMBLY	PERMEATE GPD	CAPACITY GPH	HP MOTOR	HP PUMP	BOOSTER MOTOR	BOOSTER PUMP	MEMBERANE	DRY WT lbs	WET WT lbs
A455C-2800	110/220AC 50/60Hz 1/3PH	0151010	2800	117	15AC062412	81012026	1519081110	1221515772	4x 2724011333	570 (258 kg)	591 (269 kg)
A455C-3600	110/220AC 50/60Hz 1/3PH	0151010	3600	150	15AC062412	81012026	1519081110	1221515772	4x 2724011433	570 (258 kg)	591 (269 kg)
A455C-4400	110/220AC /50/60Hz 1/3PH	0151009	4400	183	1567283319	12180523CO	1544182210	1217514773	6x 2724011333	600 (272 kg)	623 (283 kg)
A455C-5200	110/220/380/440AC 50/60Hz 1/3PH	0151009	5200	217	1567283319	12180523CO	1544182210	1217514773	6x 2724011433	650 (296 kg)	676 (307 kg)
A455C-5800	110/220/380/440AC 50/60Hz 1/3PH	0151009	5800	217	1567283319	12180523CO	1544182210	1217514773	8x 2724011333	700 (319 kg)	728 (331 kg)
A455C-6800	110/220/380/440AC 50/60Hz 1/3PH	0151009	6800	283	1567283319	12180523CO	1544182210	1217514773	8x 2724011433	750 (342 kg)	780 (355 kg)

SIZE	DWG NO	REV
D	A455C-TM	-
SCALE	NTS	3 of 6

DRAWING A455C-TM

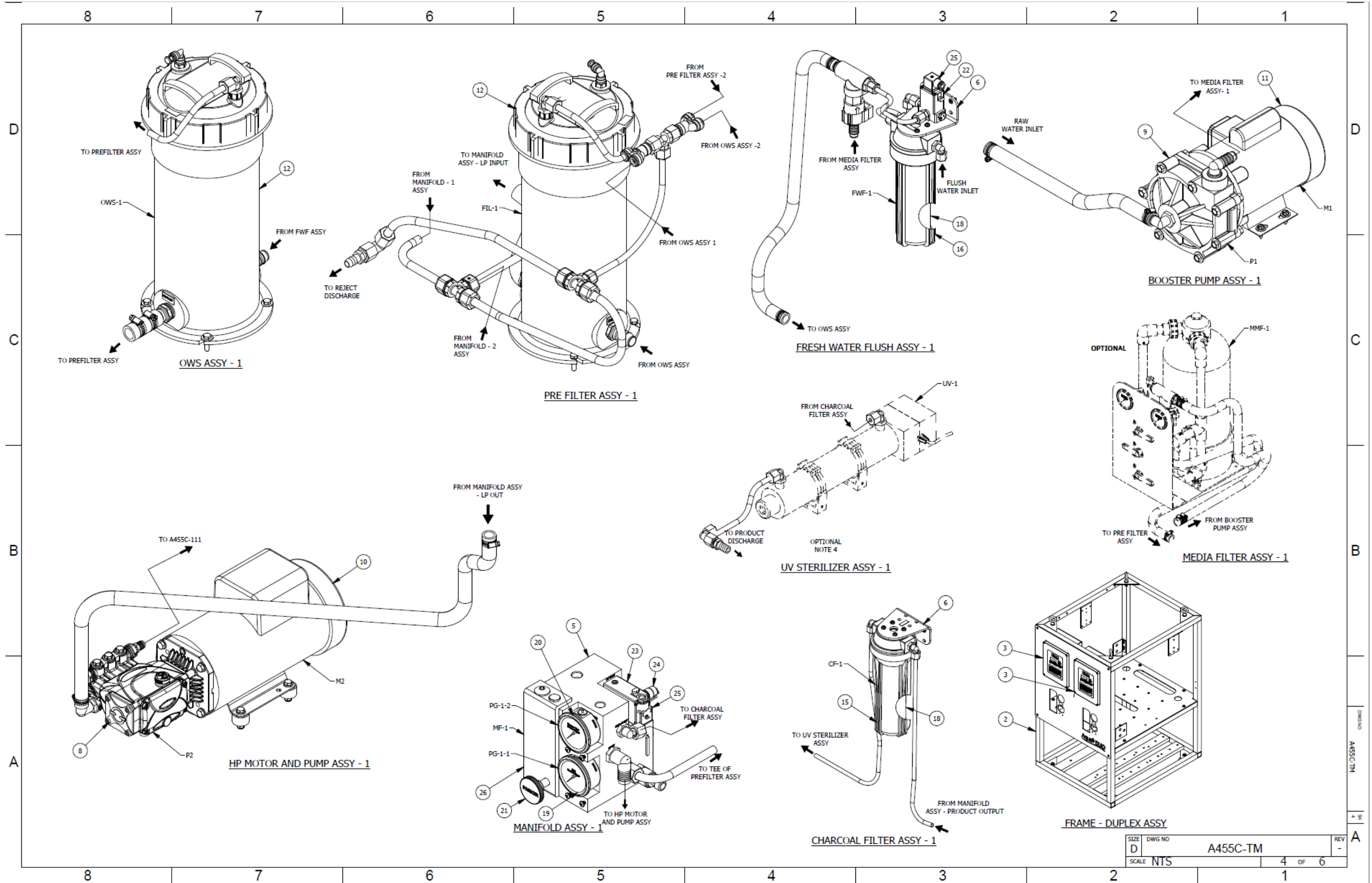

SIZE	DWG NO	REV
D	A455C-TM	1
SCALE	NTS	4 OF 6

DWG NO A455C-TM

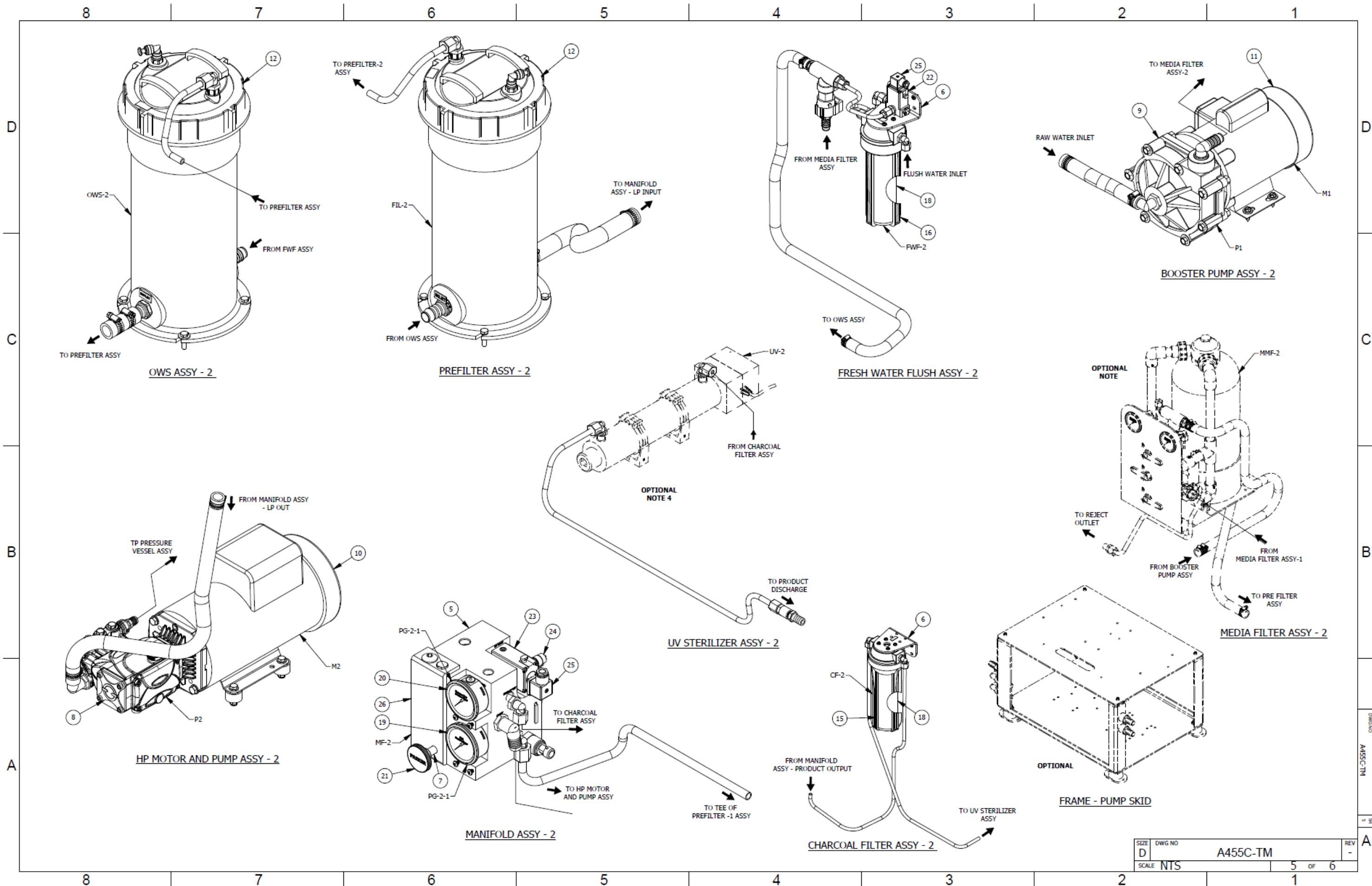

8 7 6 5 4 3 2 1

D
C
B
A

D
C
B
A

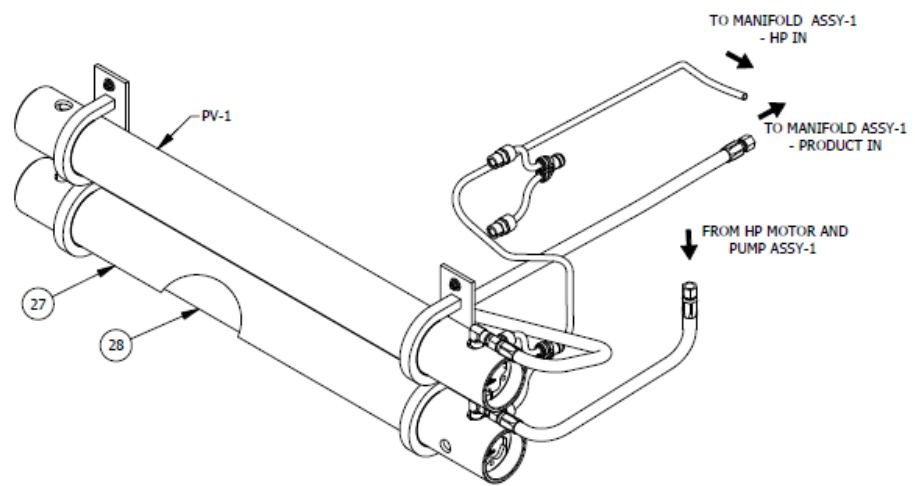

PRESSURE VESSEL ASSY-1 (SMALLER)

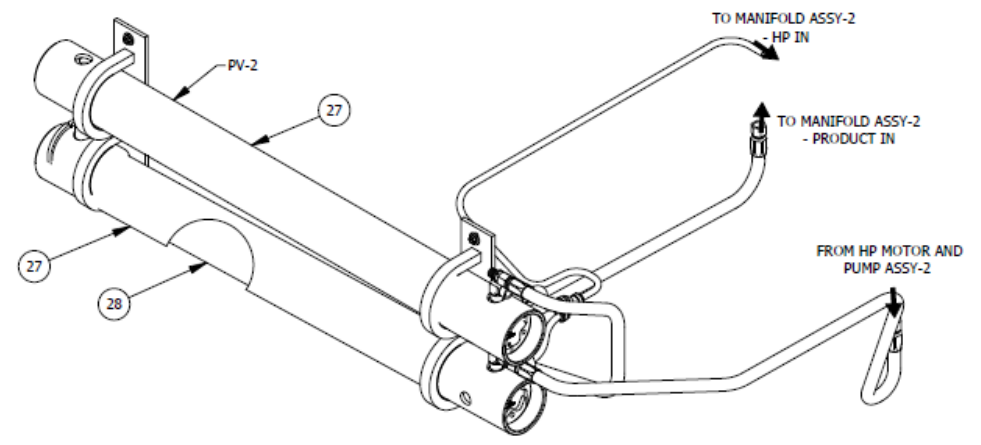

PRESSURE VESSEL ASSY-2 (SMALLER)

ITEM 27 VESSEL ASSY
(REF TO DWG 2408132500-01)
USES ITEM 28 ONE ELEMENT
(2724011233)

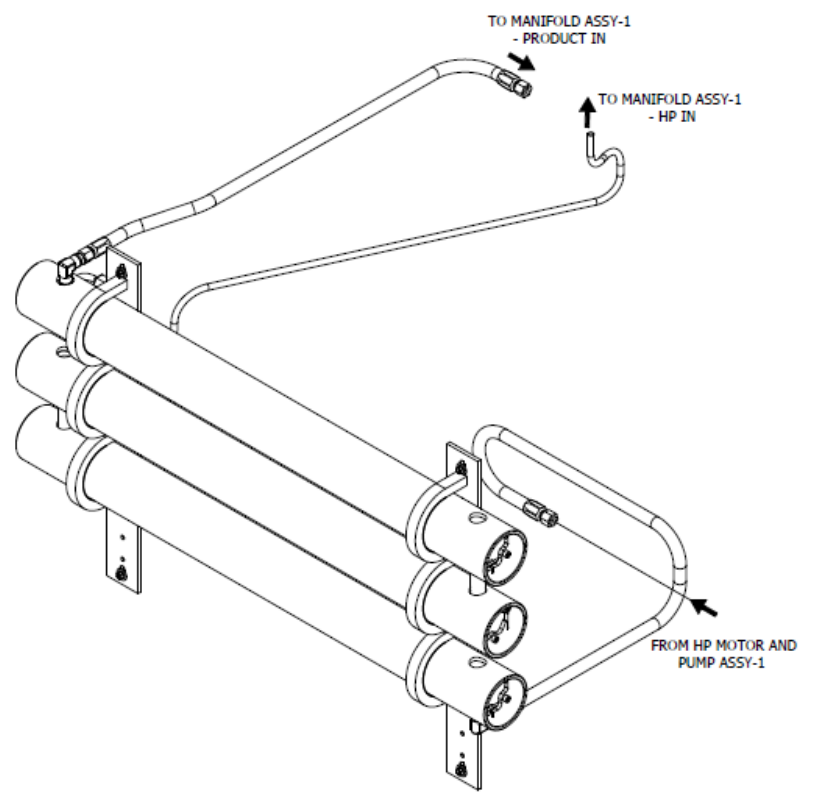

PRESSURE VESSEL ASSY-1 (LARGER)

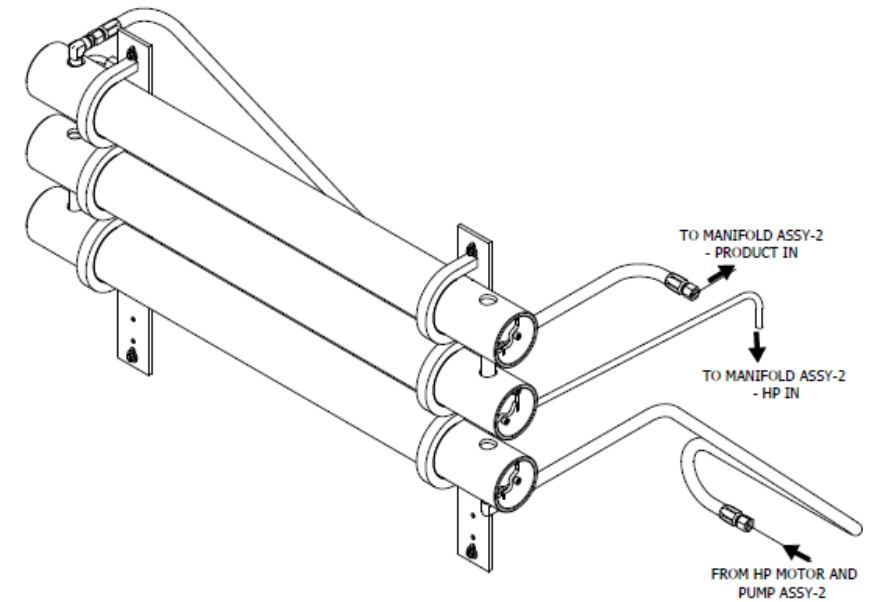

PRESSURE VESSEL ASSY-2 (LARGER)

8 7 6 5 4 3 2 1

SIZE	DWG NO	REV
D	A455C-TM	A
SCALE	NTS	6 OF 6

ISSUED
A455C-TM
6

ASSY NUMBER	VOLTAGE	MEDIA FILTER ASSEMBLY	PERMEATE GPD	CAPACITY GPH	HP MOTOR	HP PUMP	BOOSTER MOTOR	BOOSTER PUMP	MEMBERANE	DRY WT lbs	WET WT lbs
A455C-2800	110/220AC 50/60Hz 1/3PH	0151010	2800	117	15AC062412	81012026	1519081110	1221515772	4x 2724011333	570 (258 kg)	591 (269 kg)
A455C-3600	110/220AC 50/60Hz 1/3PH	0151010	3600	150	15AC062412	81012026	1519081110	1221515772	4x 2724011433	570 (258 kg)	591 (269 kg)
A455C-4400	110/220AC /50/60Hz 1/3PH	0151009	4400	183	1567283319	12180523CO	1544182210	1217514773	6x 2724011333	600 (272 kg)	623 (283 kg)
A455C-5200	110/220/380/440AC 50/60Hz 1/3PH	0151009	5200	217	1567283319	12180523CO	1544182210	1217514773	6x 2724011433	650 (296 kg)	676 (307 kg)
A455C-5800	110/220/380/440AC 50/60Hz 1/3PH	0151009	5800	217	1567283319	12180523CO	1544182210	1217514773	8x 2724011333	700 (319 kg)	728 (331 kg)
A455C-6800	110/220/380/440AC 50/60Hz 1/3PH	0151009	6800	283	1567283319	12180523CO	1544182210	1217514773	8x 2724011433	750 (342 kg)	780 (355 kg)

4 - Wiring Diagrams

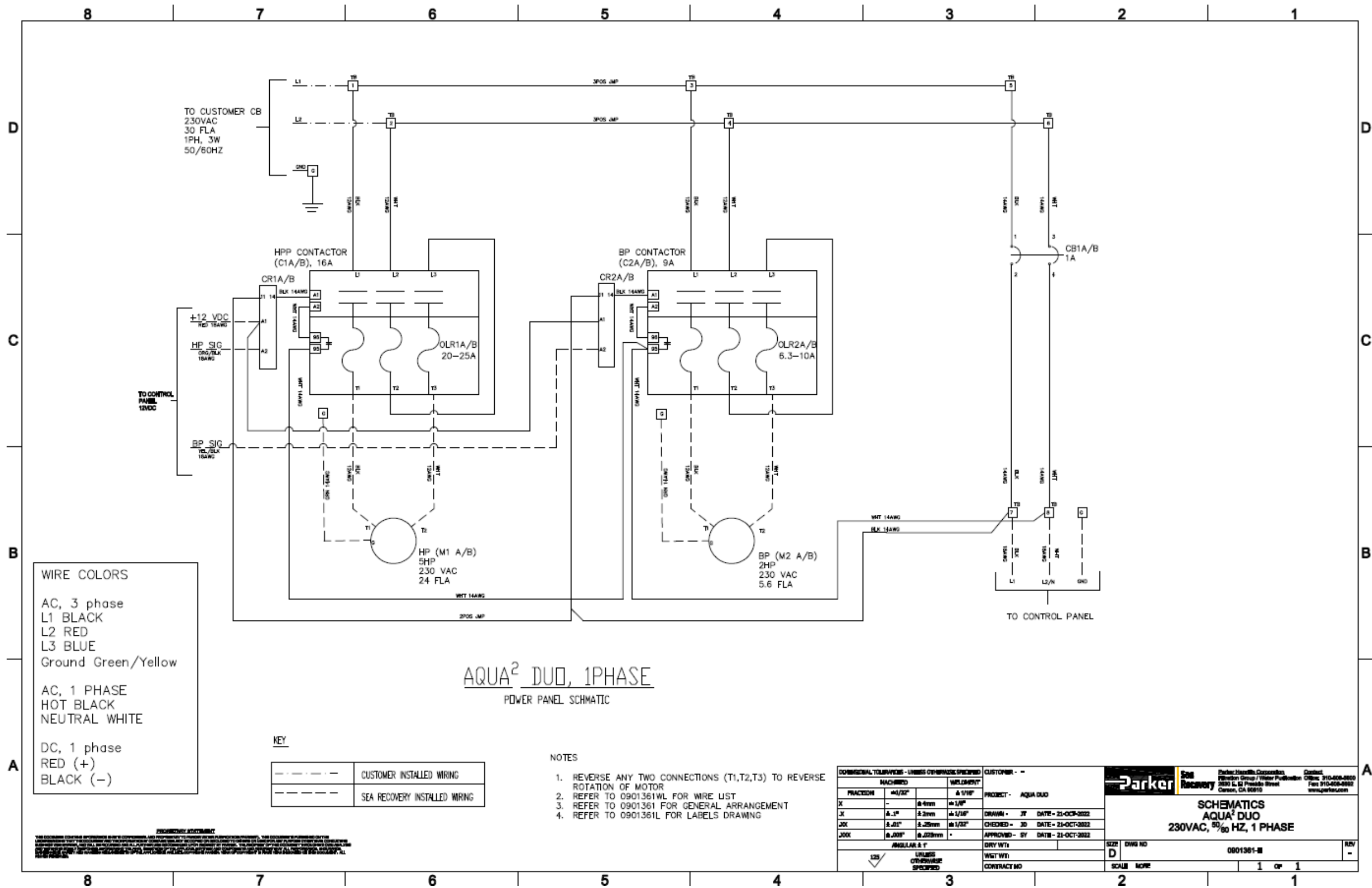

WIRE COLORS

AC, 3 phase
 L1 BLACK
 L2 RED
 L3 BLUE
 Ground Green/Yellow

AC, 1 PHASE
 HOT BLACK
 NEUTRAL WHITE

DC, 1 phase
 RED (+)
 BLACK (-)

KEY

---	CUSTOMER INSTALLED WIRING
---	SEA RECOVERY INSTALLED WIRING

AQUA² DUO, 1PHASE
 POWER PANEL SCHEMATIC

- NOTES**
1. REVERSE ANY TWO CONNECTIONS (T1,T2,T3) TO REVERSE ROTATION OF MOTOR
 2. REFER TO 0901361WL FOR WIRE LIST
 3. REFER TO 0901361 FOR GENERAL ARRANGEMENT
 4. REFER TO 0901361L FOR LABELS DRAWING

FRACCTION	MAJOR	MINOR	WELDED	PROJECT
X	1/2"	1/8"	1/16"	AQUA DUO
X	3/8"	3/32"	1/16"	
X	1/2"	3/32"	1/16"	
X	3/8"	3/32"		

Parker Sea Recovery

SCHEMATICS
AQUA² DUO
230VAC, 50/60 HZ, 1 PHASE

0901361-B

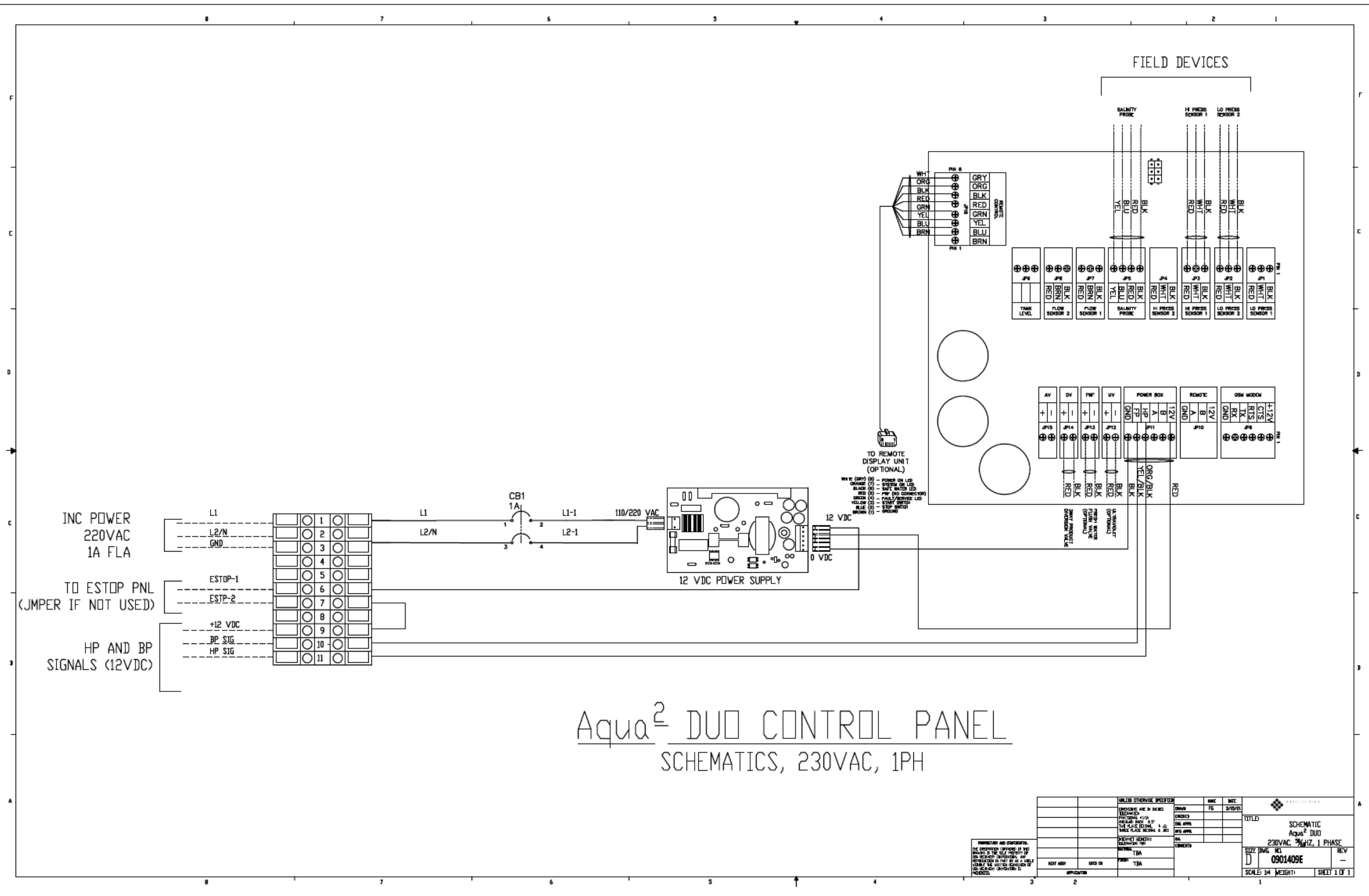

Aqua² DUO CONTROL PANEL

SCHEMATICS, 230VAC, 1PH

UNLESS OTHERWISE SPECIFIED DIMENSIONS ARE IN INCHES TOLERANCES FINISHES THE ABOVE DIMENSIONS ARE FOR REFERENCE ONLY AND SHALL NOT BE USED FOR CONSTRUCTION OF THE PANEL.		DATE: 3/15/11 DRAWN: FE CHECKED: [blank] DESIGNED: [blank]	MFC DATE: 3/15/11
PROPRIETARY AND CONFIDENTIAL THE INFORMATION CONTAINED HEREIN IS THE PROPERTY OF AND SHALL NOT BE DISCLOSED OR REPRODUCED IN ANY MANNER WITHOUT THE WRITTEN PERMISSION OF FLOURENCE.		TITLED SCHEMATIC Aqua ² DUO 230VAC, 1PHASE	
SIZE: 1/8" x 1/2" x 1/4" Dwg No: 0901409E SCALE: 1/4" = 1" SHEET 1 OF 1	REV 1 DATE: 3/15/11		

REV	DESCRIPTION	D-TE	APPROVED
1	AS BUILT UPDATES	13-OCT-2022	JD

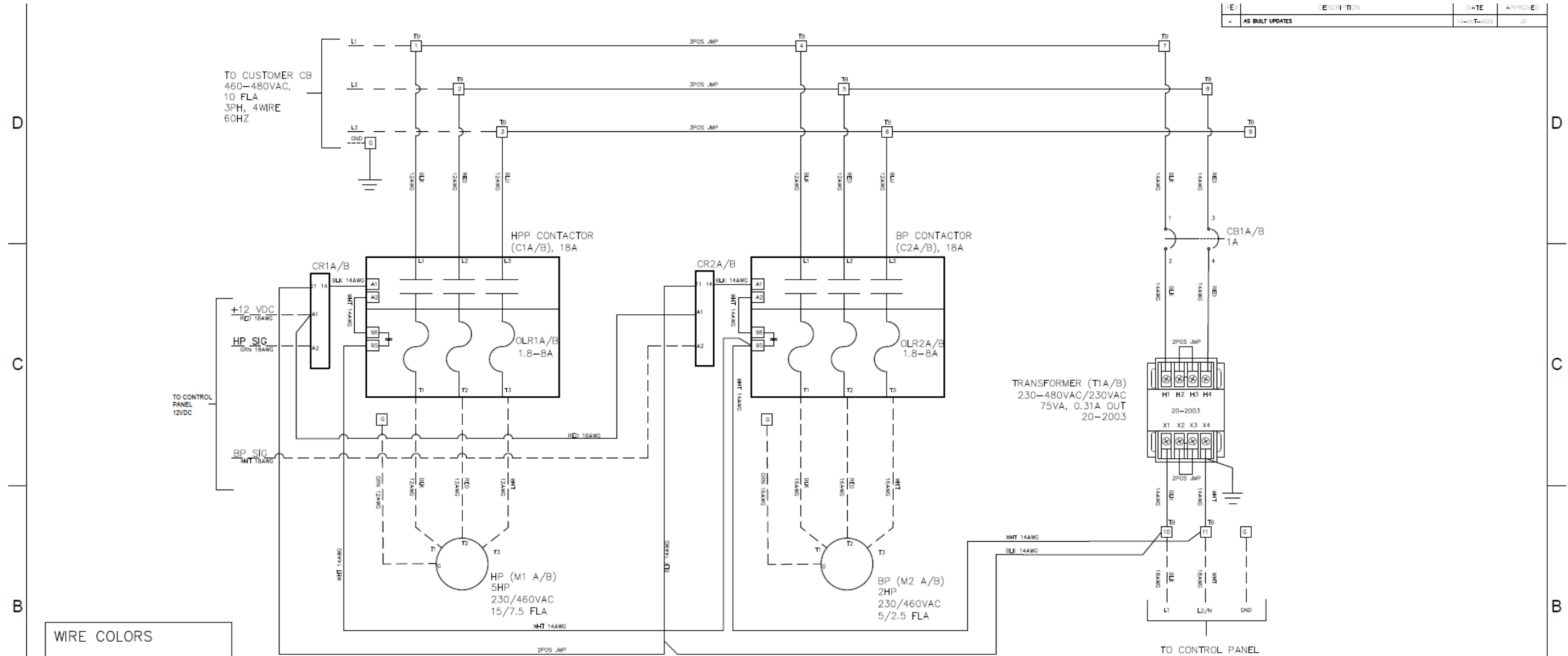

WIRE COLORS

AC, 3 phase
L1 BLACK
L2 RED
L3 BLUE
Ground Green/Yellow

AC, 1 PHASE
HOT BLACK
NEUTRAL WHITE

DC, 1 phase
RED (+)
BLACK (-)

AQUA² DUO, 3PHASE
POWER PANEL SCHEMATIC

KEY

---	CUSTOMER INSTALLED WIRING
---	SEA RECOVERY INSTALLED WIRING

- NOTES**
1. REVERSE ANY TWO CONNECTIONS (T1,T2,T3) TO REVERSE ROTATION OF MOTOR
 2. REFER TO 0901360-WL FOR WIRE LIST
 3. REFER TO 0901360 FOR GENERAL ARRANGEMENT
 4. REFER TO 0901360-L FOR LABELS DRAWING
 5. USED WITH POWER PANEL 0901360 & 0901375

DIMENSIONAL TOLERANCES - UNLESS OTHERWISE SPECIFIED			CUSTOMER -	
FRACTION	MACHINED	WELDMENT	PROJECT -	AQUA DUO
X	-	± 1/16"	DRAWN -	JPD DATE - 21-OCT-2022
.X	± .1"	± 1/32"	CHECKED -	JT DATE - 21-OCT-2022
.XX	± .01"	± .25mm	APPROVED -	SY DATE - 21-OCT-2022
.XXX	± .005"	± .025mm	DRY WT:	
ANGULAR ± 1°			WET WT:	
UNLESS OTHERWISE SPECIFIED			CONTRACT NO	

Parker **Sea Recovery**

Parker Hannifin Corporation
Filtration Group / Water Purification Office: 310-608-5600
2630 E. El Presidio Street
Carson, CA 90810 Fax: 310-608-5692
www.parker.com

SCHEMATICS
AQUA² DUO
460-480VAC, 60HZ, 3 PHASE

SIZE D DWG NO 0901360-E REV A
SCALE NONE 1 OF 1

PROPRIETARY STATEMENT

THIS DOCUMENT CONTAINS INFORMATION THAT IS CONFIDENTIAL AND PROPRIETARY TO PARKER WATER PURIFICATION (PARKER). THIS DOCUMENT IS FURNISHED ON THE UNDERSTANDING THAT THE DOCUMENT AND THE INFORMATION IT CONTAINS WILL NOT BE COPIED OR DISCLOSED TO OTHERS OR USED FOR ANY PURPOSES OTHER THAN CONDUCTING BUSINESS WITH PARKER, AND WILL BE RETURNED AND ALL PARTS AND USE DISCONTINUED UPON REQUEST BY PARKER. THE RECEIPT OF THIS DOCUMENT THROUGH ITS COMPANY'S AND TESTING IS SOLELY RESPONSIBLE FOR MAKING THE FINAL SELECTION OF THE APPLICABLE SYSTEM AND COMPONENTS AND ASSURING THAT ALL PERFORMANCE, ENDURANCE, MAINTENANCE, SAFETY AND WARRANTY REQUIREMENTS OF THE APPLICATION ARE MET. COPYRIGHT PARKER. YEAR OF COPYRIGHT IS FIRST YEAR INDICATED ON THIS DOCUMENT. ALL RIGHTS RESERVED.

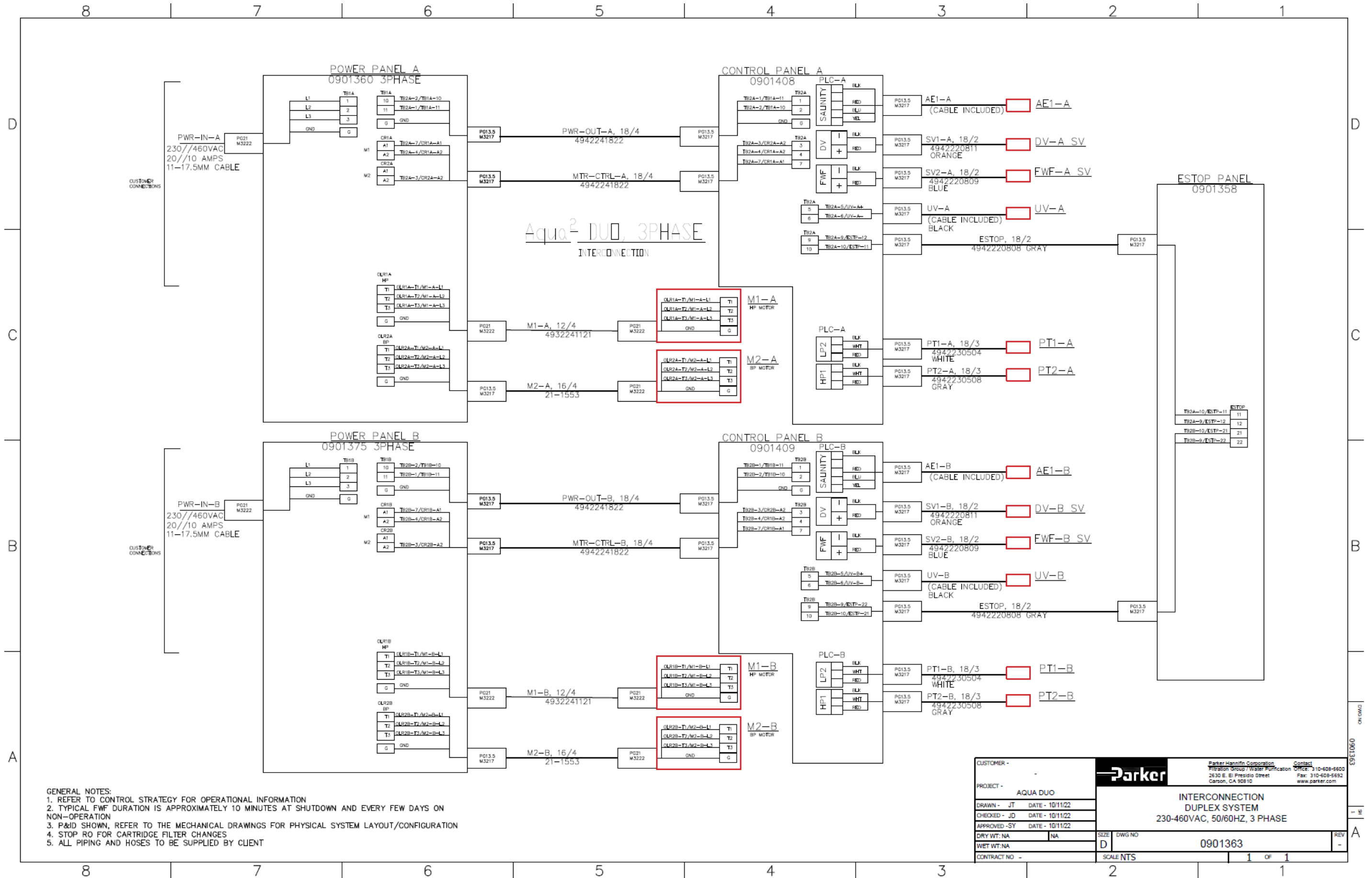

CUSTOMER -		Parker		Parker Hannifin Corporation Filtration Group / Water Purification Office: 310-608-6600 2630 E. El Presidio Street Carson, CA 90810 Fax: 310-608-5692 www.parker.com	
PROJECT -		INTERCONNECTION DUPLIX SYSTEM 230-460VAC, 50/60HZ, 3 PHASE			
DRAWN - JT	DATE - 10/11/22	SIZE		DWG NO	
CHECKED - JD	DATE - 10/11/22	D		0901363	
APPROVED - SY	DATE - 10/11/22	SCALE		NTS	
DRY WT: NA	NA	REV		-	
WET WT: NA	NA	1		OF 1	
CONTRACT NO -		1 OF 1			