

Operating Instructions

Pressure sensor with ceramic measuring cell

VEGABAR 18

Two-wire 4 ... 20 mA



Document ID: 55575



VEGA

Contents

1	About this document	4
1.1	Function	4
1.2	Target group	4
1.3	Symbols used	4
2	For your safety	5
2.1	Authorised personnel	5
2.2	Appropriate use	5
2.3	Warning about incorrect use	5
2.4	General safety instructions	5
2.5	Installation and operation in the USA and Canada	5
3	Product description	7
3.1	Configuration	7
3.2	Principle of operation	8
3.3	Adjustment	10
3.4	Packaging, transport and storage	10
3.5	Accessories	11
4	Mounting	12
4.1	General instructions	12
4.2	Process pressure measurement	14
5	Connecting to power supply	16
5.1	Preparing the connection	16
5.2	Connection procedure	16
5.3	Wiring plan	18
5.4	Switch-on phase	18
6	Diagnostics and servicing	19
6.1	Maintenance	19
6.2	Rectify faults	19
6.3	Diagnosis, fault messages	20
6.4	How to proceed if a repair is necessary	20
7	Dismount	21
7.1	Dismounting steps	21
7.2	Disposal	21
8	Certificates and approvals	22
8.1	EU conformity	22
8.2	NAMUR recommendations	22
8.3	Environment management system	22
9	Supplement	23
9.1	Technical data	23
9.2	Dimensions	27
9.3	Industrial property rights	29
9.4	Licensing information for open source software	29
9.5	Trademark	29

**Safety instructions for Ex areas**

Take note of the Ex specific safety instructions for Ex applications. These instructions are attached as documents to each instrument with Ex approval and are part of the operating instructions.

Editing status: 2021-02-25

1 About this document

1.1 Function

This instruction provides all the information you need for mounting, connection and setup as well as important instructions for maintenance, fault rectification, the exchange of parts and the safety of the user. Please read this information before putting the instrument into operation and keep this manual accessible in the immediate vicinity of the device.

1.2 Target group

This operating instructions manual is directed to trained personnel. The contents of this manual must be made available to the qualified personnel and implemented.

1.3 Symbols used



Document ID

This symbol on the front page of this instruction refers to the Document ID. By entering the Document ID on www.vega.com you will reach the document download.



Information, note, tip: This symbol indicates helpful additional information and tips for successful work.



Note: This symbol indicates notes to prevent failures, malfunctions, damage to devices or plants.



Caution: Non-observance of the information marked with this symbol may result in personal injury.



Warning: Non-observance of the information marked with this symbol may result in serious or fatal personal injury.



Danger: Non-observance of the information marked with this symbol results in serious or fatal personal injury.



Ex applications

This symbol indicates special instructions for Ex applications.



List

The dot set in front indicates a list with no implied sequence.



Sequence of actions

Numbers set in front indicate successive steps in a procedure.



Battery disposal

This symbol indicates special information about the disposal of batteries and accumulators.

2 For your safety

2.1 Authorised personnel

All operations described in this documentation must be carried out only by trained, qualified personnel authorised by the plant operator.

During work on and with the device, the required personal protective equipment must always be worn.

2.2 Appropriate use

The VEGABAR 18 is a pressure transmitter for process pressure measurement.

You can find detailed information about the area of application in chapter " *Product description*".

Operational reliability is ensured only if the instrument is properly used according to the specifications in the operating instructions manual as well as possible supplementary instructions.

2.3 Warning about incorrect use

Inappropriate or incorrect use of this product can give rise to application-specific hazards, e.g. vessel overfill through incorrect mounting or adjustment. Damage to property and persons or environmental contamination can result. Also, the protective characteristics of the instrument can be impaired.

2.4 General safety instructions

This is a state-of-the-art instrument complying with all prevailing regulations and directives. The instrument must only be operated in a technically flawless and reliable condition. The operator is responsible for the trouble-free operation of the instrument. When measuring aggressive or corrosive media that can cause a dangerous situation if the instrument malfunctions, the operator has to implement suitable measures to make sure the instrument is functioning properly.

The safety instructions in this operating instructions manual, the national installation standards as well as the valid safety regulations and accident prevention rules must be observed by the user.

For safety and warranty reasons, any invasive work on the device beyond that described in the operating instructions manual may be carried out only by personnel authorised by the manufacturer. Arbitrary conversions or modifications are explicitly forbidden. For safety reasons, only the accessory specified by the manufacturer must be used.

To avoid any danger, the safety approval markings and safety tips on the device must also be observed.

2.5 Installation and operation in the USA and Canada

This information is only valid for USA and Canada. Hence the following text is only available in the English language.

Installations in the US shall comply with the relevant requirements of the National Electrical Code (ANSI/NFPA 70).

Installations in Canada shall comply with the relevant requirements of the Canadian Electrical Code.

3 Product description

3.1 Configuration

Scope of delivery

The scope of delivery encompasses:

- VEGABAR 18 pressure transmitter
- Information sheet "Documents and software" with:
 - Instrument serial number
 - QR code with link for direct scanning



Note:

Optional instrument features are also described in this operating instructions manual. The respective scope of delivery results from the order specification.

Scope of this operating instructions

This operating instructions manual applies to the following instrument versions:

- Hardware version from 1.0.0
- Software version from 1.0.0

Constituent parts

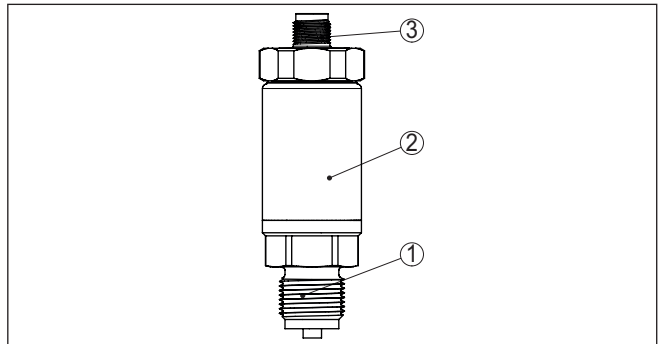

Fig. 1: Components of VEGABAR 18

- 1 Process fitting
- 2 Electronics housing
- 3 Plug connector

Type label

The type label contains the most important data for identification and use of the instrument.

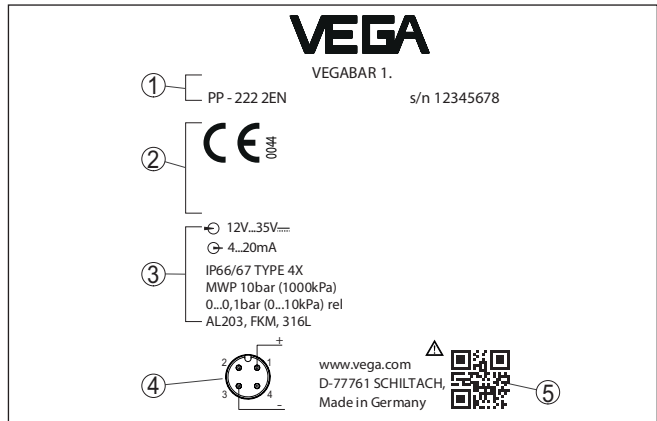

Fig. 2: Layout of the type label (example)

- 1 Instrument type, order and serial number
- 2 Field for approvals
- 3 Technical data
- 4 Assignment
- 5 QR code for device documentation

Documents and software Move to "www.vega.com" and enter in the search field the serial number of your instrument.

There you can find the following information about the instrument:

- Order data
- Documentation
- Software

Alternatively, you can find all via your smartphone:

- Scan the QR-code on the type label of the device or
- Enter serial number manually in the VEGA Tools app (available free of charge in the respective stores)

3.2 Principle of operation

Application area

VEGABAR 18 is suitable for applications in virtually all industries. It is used for the measurement of the following pressure types.

- Gauge pressure

Measured products

Measured products are gases, vapours and liquids.

Measured variables

The VEGABAR 18 is suitable for the measurement of the following process variables:

- Process pressure

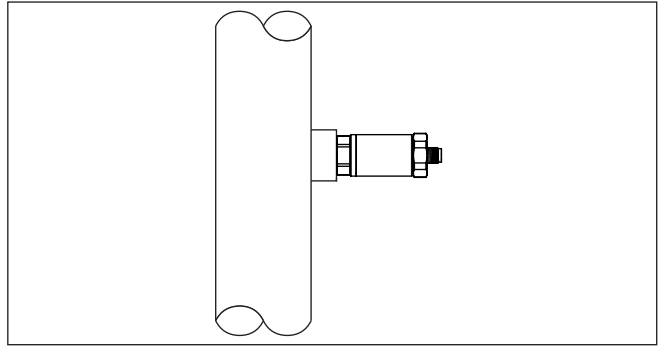

Fig. 3: Process pressure measurement VEGABAR 18

Measuring system pressure

The sensor element is the Mini-CERTEC® measuring cell with robust ceramic diaphragm. The process pressure deflects the ceramic diaphragm and causes a capacitance change in the measuring cell. This capacitance change is converted into an electrical signal and outputted as measured value via the output signal.

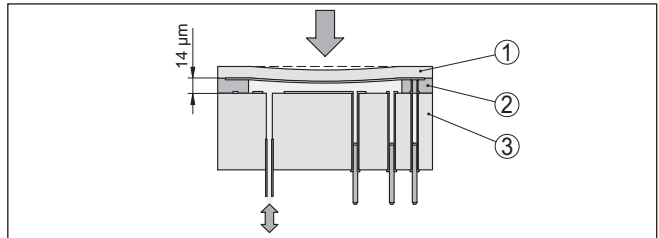

Fig. 4: Configuration of the Mini-CERTEC® measuring cell

- 1 Process diaphragm
- 2 Glass joint
- 3 Base element

Pressure types

Relative pressure: the measuring cell is open to the atmosphere. The ambient pressure is detected in the measuring cell and compensated. It thus has no influence on the measured value.

Recessed installation

The recessed installation is particularly suitable for applications with gases, vapours and clear liquids. The measuring cell seal is positioned laterally as well as in addition in front.

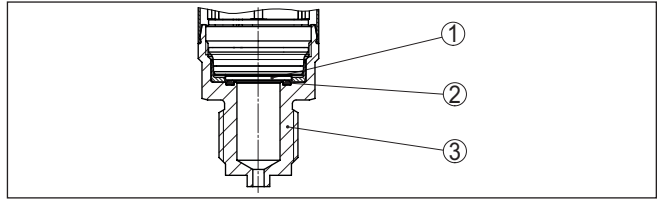

Fig. 5: Recessed installation of the measuring cell (example: thread G $\frac{1}{2}$, EN 837 manometer connection)

- 1 Measuring cell
- 2 Seal for the measuring cell
- 3 Process fitting

3.3 Adjustment

The instrument offers no adjustment options.

3.4 Packaging, transport and storage

Packaging

Your instrument was protected by packaging during transport. Its capacity to handle normal loads during transport is assured by a test based on ISO 4180.

The packaging consists of environment-friendly, recyclable cardboard. For special versions, PE foam or PE foil is also used. Dispose of the packaging material via specialised recycling companies.

Transport

Transport must be carried out in due consideration of the notes on the transport packaging. Nonobservance of these instructions can cause damage to the device.

Transport inspection

The delivery must be checked for completeness and possible transit damage immediately at receipt. Ascertained transit damage or concealed defects must be appropriately dealt with.

Storage

Up to the time of installation, the packages must be left closed and stored according to the orientation and storage markings on the outside.

Unless otherwise indicated, the packages must be stored only under the following conditions:

- Not in the open
 - Dry and dust free
 - Not exposed to corrosive media
 - Protected against solar radiation
 - Avoiding mechanical shock and vibration
- Storage and transport temperature see chapter " *Supplement - Technical data - Ambient conditions*"
 - Relative humidity 20 ... 85 %

Storage and transport temperature

3.5 Accessories

The instructions for the listed accessories can be found in the download area on our homepage.

Welded sockets and adapters

Welded sockets are used to connect the devices to the process.

Threaded adapters enable simple adaptation of devices with standard threaded fittings, e.g. to process-side hygiene connections.

Mounting accessories

The suitable mounting accessories for VEGABAR 18 includes siphons, blocking valves and measuring instrument holders.

4 Mounting

4.1 General instructions

Ambient conditions

The instrument is suitable for standard and extended ambient conditions acc. to DIN/EN/IEC/ANSI/ISA/UL/CSA 61010-1. It can be used indoors as well as outdoors.

Process conditions



Note:

For safety reasons, the instrument must only be operated within the permissible process conditions. You can find detailed information on the process conditions in chapter " *Technical data*" of the operating instructions or on the type label.

Hence make sure before mounting that all parts of the instrument exposed to the process are suitable for the existing process conditions.

These are mainly:

- Active measuring component
- Process fitting
- Process seal

Process conditions in particular are:

- Process pressure
- Process temperature
- Chemical properties of the medium
- Abrasion and mechanical influences

Permissible process pressure (MWP) - Device

The permissible process pressure range is specified by "MWP" (Maximum Working Pressure) on the type label, see chapter " *Structure*". The MWP takes the element of the measuring cell and processing fitting combination with the weakest pressure into consideration and may applied permanently. The specification refers to a reference temperature of +20 °C (+68 °F). It also applies when a measuring cell with a higher measuring range than the permissible pressure range of the process fitting is installed order-related.

In order to prevent damage to the device, a test pressure may only exceed the specified MWP briefly by 1.5 times at reference temperature. The pressure stage of the process fitting as well as the overload resistance of the measuring cell are taken into consideration here (see chapter " *Technical Data*").

In addition, a temperature derating of the process fitting, e. g. with flanges, can limit the permissible process pressure range according to the respective standard.

Protection against moisture

Protect your instrument against moisture ingress through the following measures:

- Use a suitable connection cable (see chapter " *Connecting to power supply*")
- Tighten the cable gland or plug connector
- Lead the connection cable downward in front of the cable entry or plug connector

This applies mainly to outdoor installations, in areas where high humidity is expected (e.g. through cleaning processes) and on cooled or heated vessels.

Ventilation and pressure compensation

Ventilation and pressure compensation for VEGABAR 18 are provided by an air-permeable, moisture-blocking filter element.

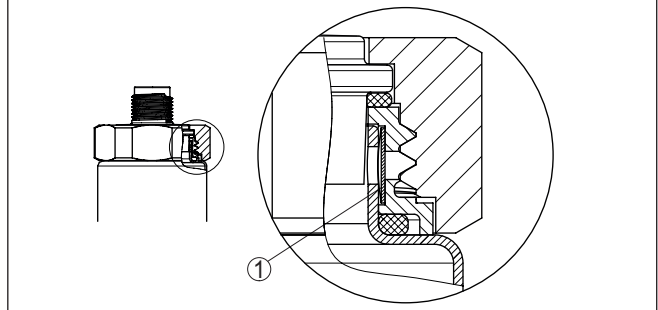

Fig. 6: Position of the filter element

1 Filter element

For effective ventilation, the filter element must always be free of buildup.



Caution:

Do not use a high-pressure cleaner. The filter element could be damaged, which would allow moisture into the housing.

Screwing in

Devices with threaded fitting are screwed into the process fitting with a suitable wrench via the hexagon.

See chapter "Dimensions" for wrench size.



Warning:

The housing or the electrical connection may not be used for screwing in! Depending on the device version, tightening can cause damage, e. g. to the rotation mechanism of the housing.

Permissible process pressure (MWP) - Mounting accessory

The permissible process pressure range is stated on the type label. The instrument should only be operated with these pressures if the mounting accessory used also fulfils these values. This should be ensured by suitable flanges, welded sockets, tension rings with Clamp connections, sealings, etc.

Temperature limits

Higher process temperatures often mean also higher ambient temperatures. Make sure that the upper temperature limits stated in chapter "Technical data" for the environment of the electronics housing and connection cable are not exceeded.

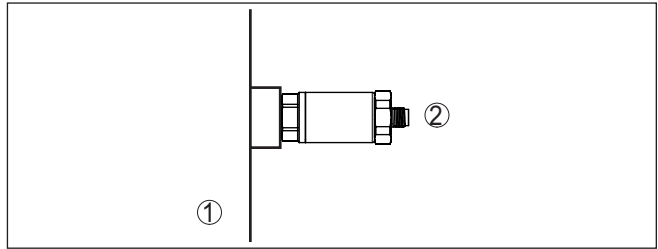

Fig. 7: Temperature ranges

- 1 Process temperature
- 2 Ambient temperature

In gases

4.2 Process pressure measurement

Keep the following in mind when setting up the measuring system:

- Mount the instrument above the measuring point

Possible condensation can then drain off into the process line.

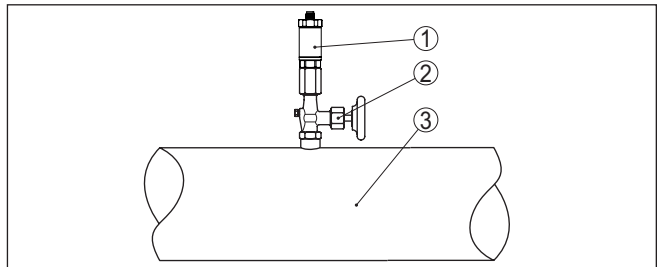

Fig. 8: Measurement setup for process pressure measurement of gases in pipelines

- 1 VEGABAR 18
- 2 Blocking valve
- 3 Pipeline

In vapours

Keep the following in mind when setting up the measuring system:

- Connect via a siphon

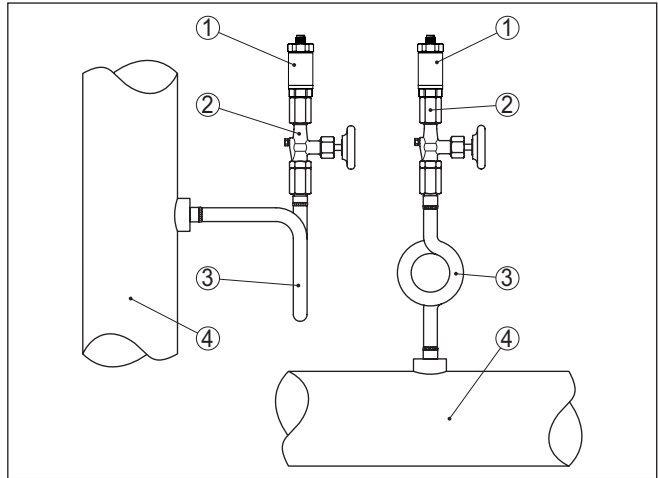

Fig. 9: Measurement setup for process pressure measurement of gases in pipelines

- 1 VEGABAR 18
- 2 Blocking valve
- 3 Siphon in U or circular form
- 4 Pipeline

A protective accumulation of water is formed through condensation in the pipe bends. Even in applications with hot steam, a medium temperature < 100 °C on the transmitter is ensured.

In liquids

Keep the following in mind when setting up the measuring system:

- Mount the instrument below the measuring point

The effective pressure line is always filled with liquid and gas bubbles can bubble up to the process line.

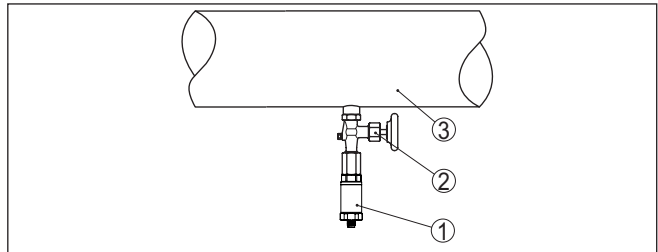

Fig. 10: Measurement setup for process pressure measurement of liquids in pipelines

- 1 VEGABAR 18
- 2 Blocking valve
- 3 Pipeline

5 Connecting to power supply

5.1 Preparing the connection

Safety instructions

Always keep in mind the following safety instructions:

- Carry out electrical connection by trained, qualified personnel authorised by the plant operator
- If overvoltage surges are expected, overvoltage arresters should be installed



Warning:

Only connect or disconnect in de-energized state.

Voltage supply

The data for power supply are specified in chapter " *Technical data*".



Note:

Power the instrument via an energy-limited circuit (power max. 100 W) acc. to IEC 61010-1, e.g.

- Class 2 power supply unit (acc. to UL1310)
- SELV power supply unit (safety extra-low voltage) with suitable internal or external limitation of the output current

Keep in mind the following additional factors that influence the operating voltage:

- Lower output voltage of the power supply unit under nominal load (e.g. with a sensor current of 20.5 mA or 22 mA in case of fault)
- Influence of additional instruments in the circuit (see load values in chapter " *Technical data*")

Connection cable

Use cable with round cross section. Depending on the plug connection, you have to select the outer diameter of the cable respectively so that the seal effect of the cable gland is ensured.

Depending on the connection method or signal output, the device is connected with standard two, three or four-wire cable without shielding.

5.2 Connection procedure

Plug according to ISO 4400

Proceed as follows:

1. Loosen the screw on the rear of the plug connector
2. Remove the plug connector and seal from VEGABAR 18
3. Remove the plug insert from the plug housing

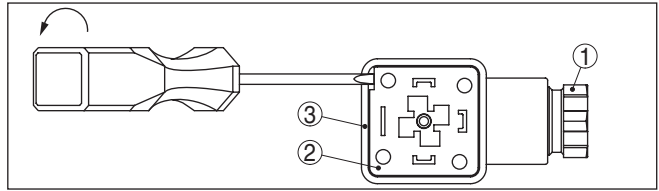

Fig. 11: Loosen the plug insert

- 1 Cable gland
- 2 Plug insert
- 3 Plug housing

- 4. Remove approx. 5 cm of the cable mantle, strip approx. 1 cm insulation from the individual wires
- 5. Lead the cable through the cable gland into the plug housing
- 6. Connect the wire ends to the screw terminals according to the wiring plan

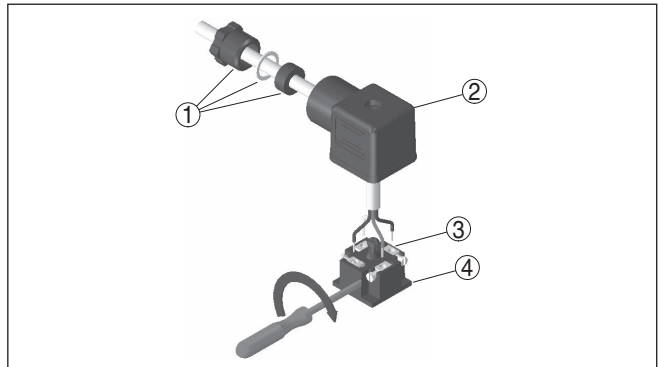

Fig. 12: Connection to the screw terminals

- 1 Cable gland
- 2 Plug housing
- 3 Plug insert
- 4 Plug seal

- 7. Snap the plug insert into the plug housing and insert the sensor seal
- 8. Plug the plug insert with seal to VEGABAR 18 and tighten the screw

The electrical connection is finished.

5.3 Wiring plan

M12 x 1 plug

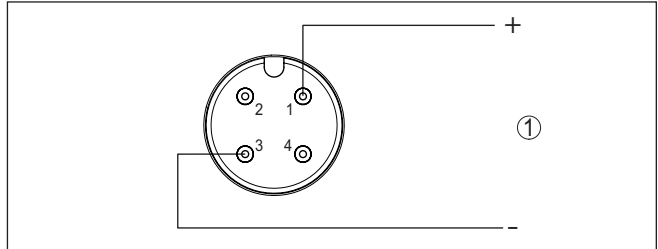

Fig. 13: Wiring plan - two-wire 4 ... 20 mA - M12 x 1 plug

1 Voltage supply and signal output

Contact, plug connector	Function/Polarity
1	Voltage supply, signal output/+
2	Free
3	Voltage supply, signal output/-
4	Free

Plug according to ISO 4400

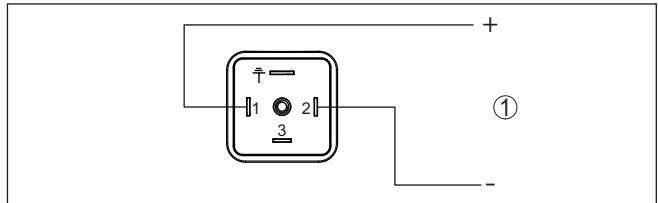



Fig. 14: Wiring plan - two-wire 4 ... 20 mA - plug according to ISO 4400

1 Voltage supply and signal output

Contact, plug connector	Function/Polarity
1	Voltage supply, signal output/+
2	Voltage supply, signal output/-
3	Free
	Electrically connected with metal housing

5.4 Switch-on phase

After switching on, the device first carries out a self-check:

- Internal check of the electronics
- The output signal jumps to the set fault current

The current measured value is then output on the signal cable.

6 Diagnostics and servicing

6.1 Maintenance

Maintenance

If the device is used properly, no special maintenance is required in normal operation.

Precaution measures against buildup

In some applications, product buildup on the diaphragm can influence the measuring result. Depending on the sensor and application, take precautions to ensure that heavy buildup, and especially a hardening thereof, is avoided.

Cleaning

The cleaning helps that the type label and markings on the instrument are visible.

Take note of the following:

- Use only cleaning agents which do not corrode the housings, type label and seals
- Use only cleaning methods corresponding to the housing protection rating

6.2 Rectify faults

Reaction when malfunction occurs

The operator of the system is responsible for taking suitable measures to rectify faults.

Causes of malfunction

The device offers maximum reliability. Nevertheless, faults can occur during operation. These may be caused by the following, e.g.:

- Sensor
- Process
- Voltage supply
- Signal processing

Fault rectification

The first measures are:

- Evaluation of fault messages
- Checking the output signal
- Treatment of measurement errors

A smartphone/tablet with the adjustment app or a PC/notebook with the software PACTware and the suitable DTM offer you further comprehensive diagnostic possibilities. In many cases, the causes can be determined in this way and the faults eliminated.

Reaction after fault rectification

Depending on the reason for the fault and the measures taken, the steps described in chapter "Setup" must be carried out again or must be checked for plausibility and completeness.

24 hour service hotline

Should these measures not be successful, please call in urgent cases the VEGA service hotline under the phone no. **+49 1805 858550**.

The hotline is also available outside normal working hours, seven days a week around the clock.

Since we offer this service worldwide, the support is provided in English. The service itself is free of charge, the only costs involved are the normal call charges.

6.3 Diagnosis, fault messages

4 ... 20 mA signal

Connect a multimeter in the suitable measuring range according to the wiring plan. The following table describes possible errors in the current signal and helps to eliminate them:

Error	Cause	Rectification
4 ... 20 mA signal missing	Electrical connection faulty	Check connection, correct, if necessary
	Voltage supply missing	Check cables for breaks; repair if necessary
	Operating voltage too low, load resistance too high	Check, adapt if necessary
Current signal greater than 22 mA, less than 3.6 mA	Sensor electronics defective	Replace device or send in for repair depending on device version

6.4 How to proceed if a repair is necessary

You can find an instrument return form as well as detailed information about the procedure in the download area of our homepage. By doing this you help us carry out the repair quickly and without having to call back for needed information.

In case of repair, proceed as follows:

- Print and fill out one form per instrument
- Clean the instrument and pack it damage-proof
- Attach the completed form and, if need be, also a safety data sheet outside on the packaging
- Ask the agency serving you to get the address for the return shipment. You can find the agency on our homepage.

7 Dismount

7.1 Dismounting steps

**Warning:**

Before dismantling, be aware of dangerous process conditions such as e.g. pressure in the vessel or pipeline, high temperatures, corrosive or toxic media etc.

Take note of chapters "*Mounting*" and "*Connecting to voltage supply*" and carry out the listed steps in reverse order.

7.2 Disposal

The device is made of recyclable materials. For this reason, it should be disposed of by a specialist recycling company. Observe the applicable national regulations.

8 Certificates and approvals

8.1 EU conformity

The device fulfils the legal requirements of the applicable EU directives. By affixing the CE marking, we confirm the conformity of the instrument with these directives.

The EU conformity declaration can be found on our homepage.

Due to the design of its process fittings, the device does not subject of EU pressure device directive if it is operated at process pressures ≤ 200 bar.

8.2 NAMUR recommendations

NAMUR is the automation technology user association in the process industry in Germany. The published NAMUR recommendations are accepted as the standard in field instrumentation.

The device fulfils the requirements of the following NAMUR recommendations:

- NE 21 – Electromagnetic compatibility of equipment
- NE 43 – Signal level for fault information from measuring transducers

For further information see www.namur.de.

8.3 Environment management system

Protection of the environment is one of our most important duties. That is why we have introduced an environment management system with the goal of continuously improving company environmental protection. The environment management system is certified according to DIN EN ISO 14001. Please help us fulfil this obligation by observing the environmental instructions in chapters "*Packaging, transport and storage*", "*Disposal*" of these operating instructions.

9 Supplement

9.1 Technical data

Note for approved instruments

The technical data in the respective safety instructions which are included in delivery are valid for approved instruments (e.g. with Ex approval). These data can differ from the data listed herein, for example regarding the process conditions or the voltage supply.

All approval documents can be downloaded from our homepage.

Materials and weights

Materials, wetted parts

Process fitting	316L
Diaphragm	Sapphire-ceramic® (> 99.9 % Al ₂ O ₃ ceramic)
Measuring cell seal	FKM (VP2/A)
Seal for process fitting (in the scope of delivery)	
– Thread G½ (EN 837), manometer connection	Klingersil C-4400
– Thread G½, inside G¼ (ISO 228-1)	Klingersil C-4400

Materials, non-wetted parts

Electronics housing	316L
M12 x 1 plug connector	
– Contact support	PA
– Contacts	CuZn, nickel layer and 0.8 µm gold-plated
Plug connector according to ISO 4400	
– Contact, housing plug	PA
– Lid screw	StSt
– Contact surface	Sn
– Plug seal	Silicone
Weight	approx. 0.25 kg (0.55 lbs)

Torques

Max. torques	
– Thread G½ (EN 837), manometer connection	50 Nm (36.88 lbf ft)
– Thread G½, inside G¼ (ISO 228-1)	50 Nm (36.88 lbf ft)

Input variable

The specifications are only an overview and refer to the measuring cell. Limitations due to the material and version of the process fitting as well as the selected pressure type are possible. The specifications on the nameplate apply. ¹⁾

¹⁾ Data on overload capability apply for reference temperature.

Nominal measuring ranges and overload capability in bar/kPa

Nominal range	Overload capacity, max. pressure	Overload capacity, min. pressure
0 ... +0.1 bar/0 ... +10 kPa	+15 bar/+1500 kPa	-0.2 bar/-20 kPa
0 ... +0.4 bar/0 ... +40 kPa	+30 bar/+3000 kPa	-0.8 bar/-80 kPa
0 ... +1 bar/0 ... +100 kPa	+35 bar/+3500 kPa	-1 bar/-100 kPa
0 ... +2.5 bar/0 ... +250 kPa	+50 bar/+5000 kPa	-1 bar/-100 kPa
0 ... +5 bar/0 ... +500 kPa	+65 bar/+6500 kPa	-1 bar/-100 kPa
0 ... +10 bar/0 ... +1000 kPa	+90 bar/+9000 kPa	-1 bar/-100 kPa
0 ... +25 bar/0 ... +2500 kPa	+130 bar/+13000 kPa	-1 bar/-100 kPa

Nominal measuring ranges and overload capacity in psi

Nominal range	Overload capacity, max. pressure	Overload capacity, min. pressure
0 ... +1.5 psig	+225 psig	-3 psig
0 ... +5 psig	+435 psig	-12 psig
0 ... +15 psig	+525 psig	-14.51 psig
0 ... +30 psig	+725 psig	-14.51 psig
0 ... +75 psig	+950 psig	-14.51 psig
0 ... +150 psig	+1300 psig	-14.51 psig
0 ... +300 psig	+1900 psig	-14.51 psig

Switch-on phase

Start-up time with operating voltage U_b	≤ 1 s
Starting current for run-up time	≤ 3.6 mA

Output variable - two-wire 4 ... 20 mA

Output signal	4 ... 20 mA - passive
Connection technology	Two-wire
Range of the output signal	3.8 ... 20.5 mA
Signal resolution	5 μ A
Fault signal output current	3.6 mA
Load	See load resistance under Power supply
Transferred measured value	Pressure

Dynamic behaviour output

Dynamic characteristics - Current output ²⁾

²⁾ Depending on medium and temperature

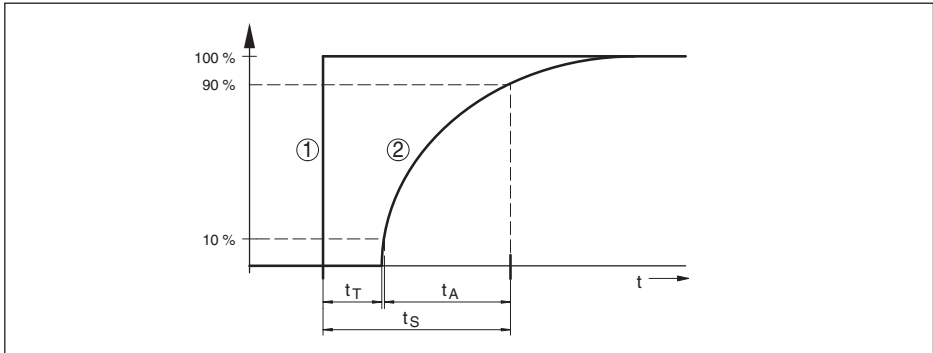

Fig. 15: Behaviour the current output in case of sudden change of the process variable. t_T : dead time; t_A : rise time; t_S : jump response time

- 1 Process variable
- 2 Output signal

Size	Time
Dead time	≤ 30 ms
Rise time (10 ... 90 %)	approx. 15 ms
Step response time (ti: 0 s, 10 ... 90 %)	approx. 45 ms

Reference conditions and influencing variables (according to DIN EN 60770-1)

Reference conditions according to DIN EN 61298-1

- Temperature +15 ... +25 °C (+59 ... +77 °F)
- Relative humidity 45 ... 75 %
- Air pressure 860 ... 1060 mbar/86 ... 106 kPa (12.5 ... 15.4 psig)
- Determination of characteristics Limit point adjustment according to IEC 61298-2
- Characteristic curve Linear
- Reference installation position upright, diaphragm points downward
- Influence of the installation position < 0.2 mbar/20 Pa (0.003 psig)

Deviation (according to IEC 60770) ³⁾

- Deviation < 0.5 %

Influence of the medium or ambient temperature

- Average temperature coefficient of the zero signal ⁴⁾ < 0.15 %/10 K

Long-term stability (according to DIN 16086)

- Long-term drift of the zero signal ⁵⁾ < 0.2 %/2 years

³⁾ Relating to the nominal measuring range, incl. non-linearity, hysteresis and non-reproducibility.
⁴⁾ In the compensated temperature range of -40 ... +100 °C (-40 ... +212 °F), reference temperature 20 °C (68 °F).
⁵⁾ Relating to the nominal measuring range.

Ambient conditions

Ambient temperature	-40 ... +70 °C (-40 ... +158 °F)
Storage and transport temperature	-40 ... +70 °C (-40 ... +158 °F)
Relative humidity	20 ... 85 %

Mechanical environmental conditions

Vibrations (oscillations)	Classe 4M8 acc. to IEC 60271-3-4 (5 g at 4 ... 200 Hz)
Impacts (mechanical shock)	Class 6M4 acc. to IEC 60271-3-6 (50 g, 2.3 ms)
Impact resistance	IK06 acc. to IEC 62262

Process conditions

Process temperature	-40 ... +100 °C (-40 ... +212 °F)
Max. permissible process pressure	see specification "MWP" on the type label ⁶⁾
Min. permissible process pressure	
– -40 ... +60 °C (-40 ... +140 °F)	2 mbar _{abs} (200 Pa _{abs})
– +60 ... +100 °C (-40 ... +212 °F)	50 mbar _{abs} (5 kPa _{abs})

Electromechanical data

Angled plug connector	
– Version	4-pin according to ISO 4400
– Cable gland	M16 x 1.5 (for cable diameter 4.5 ... 10 mm)
– Screw terminals for cable cross-section	up to 1.5 mm ² (AWG 16)
– Conductor version	Massive wire or strand
Round plug connector	4-pole with M12 x 1 screw connection

Voltage supply

Operating voltage U_B	12 ... 35 V DC
Reverse voltage protection	Integrated
Permissible residual ripple	
– for U_N 12 V DC ($12 \text{ V} < U_B < 18 \text{ V}$)	$\leq 0.7 V_{\text{eff}}$ (16 ... 400 Hz)
– for U_N 24 V DC ($18 \text{ V} < U_B < 35 \text{ V}$)	$\leq 1.0 V_{\text{eff}}$ (16 ... 400 Hz)
Load resistor	
– Calculation	$(U_B - U_{\text{min}})/0.022 \text{ A}$
– Example - for $U_B = 24 \text{ V DC}$	$(24 \text{ V} - 12 \text{ V})/0.022 \text{ A} = 545 \Omega$

Electrical protective measures ⁷⁾

Potential separation	Electronics potential free up to 500 V AC
Protection rating	

⁶⁾ MWP: Maximum Working Pressure

⁷⁾ Achieving a UL-approved degree of protection requires the use of UL-certified plugs or connection sets. This is fulfilled when using the supplied plug according to ISO 4400.

Connection technology	Protection according to EN 60529/IEC 529	Protection according to UL 50
M12 x 1 plug	IP66/IP67	Type 4X
Plug according to ISO 4400	IP65	

Altitude above sea level 5000 m (16404 ft)
 Protection class III
 Pollution degree 2

9.2 Dimensions

Housing and connections

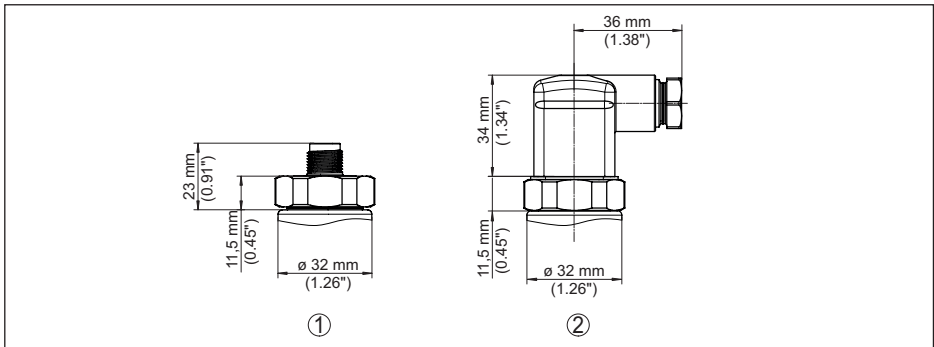

Fig. 16: VEGABAR 18 housing

- 1 M12 x 1 plug connector
- 2 Plug connector according to ISO 4400

VEGABAR 18, threaded fitting not front-flush

Fig. 17: VEGABAR 18, threaded fitting not front-flush

DU Thread G $\frac{1}{2}$ (EN 837), manometer connection

DN Thread G $\frac{1}{2}$, inside G $\frac{1}{4}$ (ISO 228-1)

LF Thread $\frac{1}{2}$ NPT, inside $\frac{1}{4}$ NPT (ASME B1.20.1)

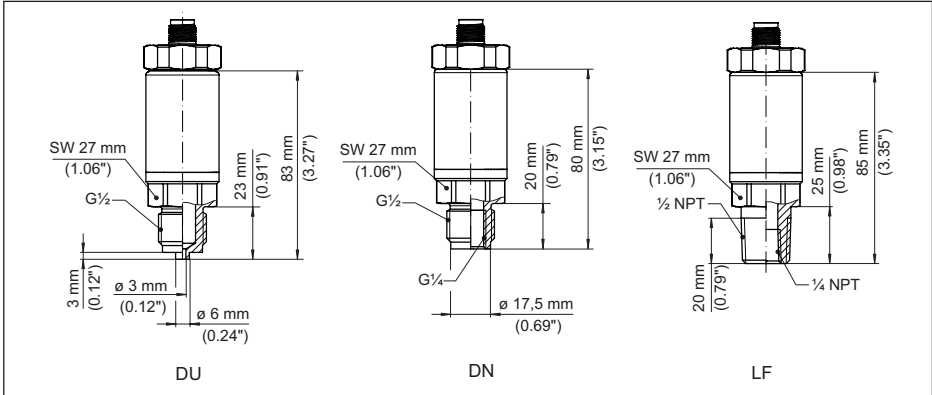
9.3 Industrial property rights

VEGA product lines are global protected by industrial property rights. Further information see www.vega.com.

VEGA Produktfamilien sind weltweit geschützt durch gewerbliche Schutzrechte.

Nähere Informationen unter www.vega.com.

Les lignes de produits VEGA sont globalement protégées par des droits de propriété intellectuelle. Pour plus d'informations, on pourra se référer au site www.vega.com.

VEGA lineas de productos están protegidas por los derechos en el campo de la propiedad industrial. Para mayor información revise la pagina web www.vega.com.

Линии продукции фирмы ВЕГА защищаются по всему миру правами на интеллектуальную собственность. Дальнейшую информацию смотрите на сайте www.vega.com.

VEGA系列产品在全球享有知识产权保护。

进一步信息请参见网站 < www.vega.com。

9.4 Licensing information for open source software

Open source software components are also used in this device. A documentation of these components with the respective license type, the associated license texts, copyright notes and disclaimers can be found on our homepage.

9.5 Trademark

All the brands as well as trade and company names used are property of their lawful proprietor/originator.





55575-EN-210301

Printing date:

VEGA

All statements concerning scope of delivery, application, practical use and operating conditions of the sensors and processing systems correspond to the information available at the time of printing.

Subject to change without prior notice

© VEGA Grieshaber KG, Schiltach/Germany 2021



55575-EN-210301

VEGA Grieshaber KG
Am Hohenstein 113
77761 Schiltach
Germany

Phone +49 7836 50-0
E-mail: info.de@vega.com
www.vega.com