

Turbine Series - 771000MA-MAM

FUEL

Specifications: Diesel Applications

Height: 22.0" (55.88 cm)

Width: 21.25" (53.98 cm) with Bracket

Depth: 12.3" (31.24 cm) with Bracket

Dry Weight: MA - 39 lbs (17.7 kg)
MAM - 42 lbs (19.1 kg)

Ports: 3/4"-14 NPT

Service Clearance (Top): 10.0" (25.4 cm)

Vacuum Installation Recommended
Maximum Head Pressure: 15 psi (1.03 bar)

Max Flow Rate: 540 gph (2044 lph)

Create a Part Number

Housing Type	Triple Assembly 540 GPH Flow Rate	Filter Model	Turbine Model 180 GPH Flow Rate (X3)	Assembly Options	Metal Bowl Option *	Filtration Rating	10 micron	30 micron *
	77		1000MA		M		10	30

* Metal bowl option only available with 30 micron element

RACOR®

Dimensions:

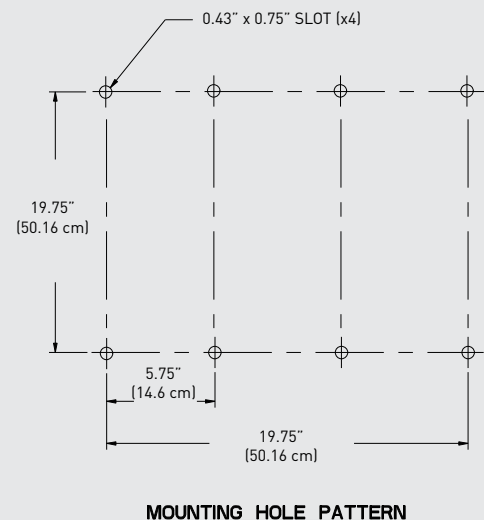
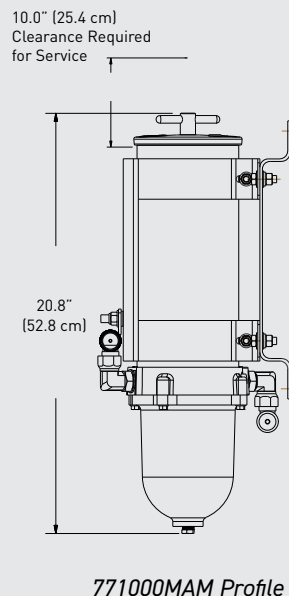
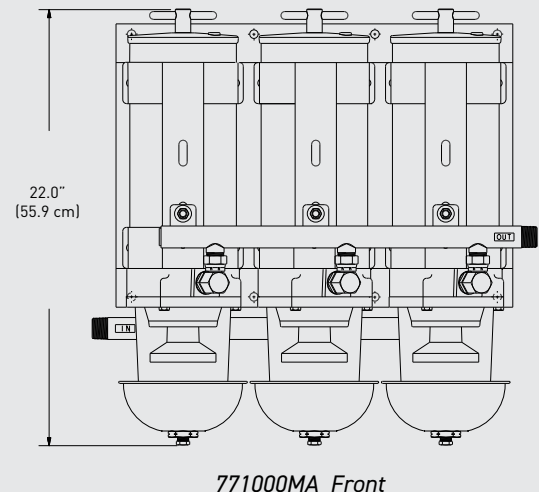
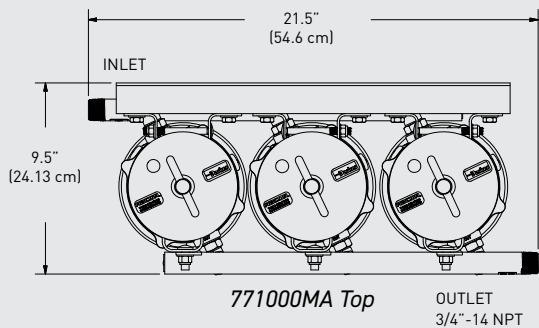

ASSEMBLY	DESCRIPTION
771000MA10	Marine - Triple 1000 Turbine Assy., 10 micron Filter
771000MA30	Marine - Triple 1000 Turbine Assy., 30 micron Filter
771000MAM30	Marine - Metal Bowl - Triple 1000 Turbine Assy., 30 micron Filter



TRIPLE ASSEMBLIES

PARTS

Turbine Series - 771000MA-MAM

1

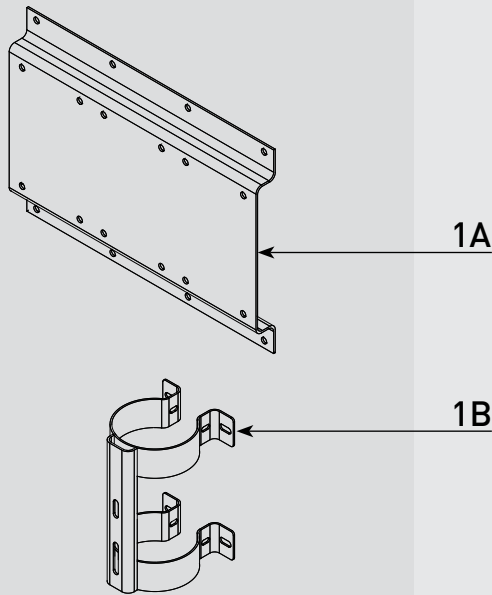

2

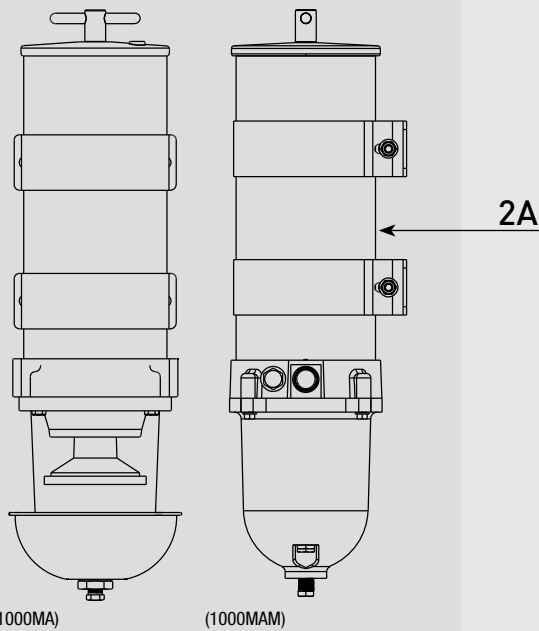

See **RSL0293**
For 1000MA-MAM Parts Breakdown

Part #	Description
1A	Mounting Bracket - <i>Contact Technical Support</i>
1B	Manifold Assembly Bracket - <i>Contact Technical Support</i>
2A	Turbine Fuel Filter - 1000MA Series See Cutsheet RSL0293 for available Parts and Accessories





Accessories and Parts Available (Not Shown)

3A	RK 11-1404	Complete Seal Service Kit - 1000MA Series Filters (Requires 3)
3B	RK 21069	WIF Probe (pig tail) - 1/2"-20 UNF - Requires Water Detection Module - Use 3C
	RK23191	WIF Probe (Steel/pig tail) - 1/2"-20 UNF - Requires Water Detection Module - Use 3C
3C	RK 14329	Water Detection Module - 12 vdc
	RK 14321	Water Detection Module - 24 vdc

4A		Bowl Gasket - Included in 5A
4B	RK 11-1606-1	MA Bowl Kit (Clear) - Includes 4A, 4C, Gasket & O-ring
4C	RK 20126	Plastic Bowl Plug Kit (MA) (O-ring Included in 3A)
4D	RK 11868	Heat Deflector Kit (MA) - Includes 4E
4E	RK 11-1910	Drain Plug Kit (MA) (Gasket & O-ring Included in 3A)

5A	2020V2	1000MA Replacement Element 2 micron
	2020V10	1000MA Replacement Element 10 micron
	2020V30	1000MA Replacement Element 30 micron

Certifications

<p>Model MA</p>  <p>LISTED</p> 	<p>Model MAM</p>  <p>LISTED</p>  <p>ABYC Setting Standards for Safer Boating</p> 
---	--



Online Link
Turbine Series Selector



Online Link
Turbine Series
Replacement Parts Selector